





## **Inspired By Challenge**

Established in 1949, with over 60 years of experience, Habonim is committed to engineering, manufacturing and supplying superior products and providing excellent personal service to our customers. We take pride in incorporating quality, innovation, reliability and safety into our products. We provide the best professional solutions for the most demanding industries, including oil and gas, chemical, petrochemical, pharmaceutical and mining. In addition to standard floating ball valves, we manufacture trunnion, cryogenic, high pressure and metal seated valves, as well as control and automation systems, pneumatic actuators and complex manifold assemblies for economical solutions to specialized tasks. Our dedicated staff focuses on developing new products while continually upgrading our existing lines. Our expertise is providing personalized solutions to each customer's unique requirements. Always keeping safety and environmental considerations in mind, Habonim products comply with the strictest industrial and international standards. Our products are highly durable under the most extreme conditions and undergo rigorous testing before being launched to the market. Expertise based on decades of experience distinguishes our company, with system based solutions being our strength and aspiration.

# VALVE SERIES

## Cryogenic valves

- C47 series
- C31/C32 series
- C73/C74 series
- C78/C77 series
- C26 series
- C28 series



## Standard valves

- 3 piece 47/26 series
- TrueBore 48 series
- Flanged 31/32, 73/74, 77/78 series
- Multiport - 61/62 series



## Metal seated valves

- Z47/Z47T series
- Z73, Z74/ Z73T, Z74T series
- Z78/Z78T/ Z77/ Z77T series
- Z28/Z28T series



## High pressure valves

- 24 series
- 27 series
- 28 series

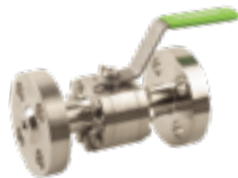

## Trunnion valves

- 2 piece Class 150 - 81 series
- 2 piece Class 300 - 82 series
- 2 piece Class 600 - 83 series
- 3 piece Class 150 - 91 series
- 3 piece Class 300 - 92 series
- 3 piece Class 600 - 93 series
- 3 piece Class 900 - 94 series
- 3 piece Class 1500 - 95 series
- 3 piece Class 2500 - 96 series



C -269°  
F -452°  
Cryogenic temperature

ANSI  
pressure  
class

2500

**C28 series**  
3 Piece  
Class 2500  
1/4" - 8"  
DN8-DN200

**C96 series**  
Trunnion  
Class 2500  
8" - 10"  
DN50-DN250

1500

**C95 series**  
Trunnion  
Class 1500  
2" - 12"  
DN50-DN300

900

**C94 series**  
Trunnion  
Class 900  
2" - 12"  
DN50-DN300

600

**C47 series**  
3 Piece  
Class 600  
1/4" - 2"  
DN8-DN50

**C26 series**  
3 Piece  
Class 600  
2" - 8"  
DN50-DN200

**DC47 series**  
3 Piece  
Class 600  
1/2" - 2"  
DN15-DN50

300

**C32 series**  
2 Piece  
Class 300/600  
2" - 12"  
DN50-DN300

**C32 series**  
1 Piece  
Class 300  
1/2" - 8"  
DN15-DN200

**C47 series**  
3 Piece  
Class 300  
2 1/2" - 6"  
DN65-DN150

**C74 series**  
1 Piece  
Class 300  
1/2" - 1"  
DN15-DN25

**C74 series**  
2 Piece  
Class 300  
1 1/2" - 8"  
DN40-DN200

150

**C61/C62 series**  
3 Piece - Multiport  
Class 300  
1/2" - 4"  
DN15-DN100

**C78 series**  
1 Piece  
PN 40  
1/2" - 1"  
DN15-DN25

**C78 series**  
2 Piece  
PN 40  
1 1/2" - 2"  
DN40-DN50

**C31 series**  
1 Piece  
Class 150  
1/2" - 8"  
DN15-DN200

**C73 series**  
1 Piece  
Class 150  
1/2" - 1"  
DN15-DN25

**C73 series**  
2 Piece  
Class 150  
1 1/2" - 8"  
DN40-DN200

**C77 series**  
2 Piece  
PN 16  
3" - 6"  
DN80-DN150

Vacuum

## Standard temperature

## High temperature

C -60°  
F -76°

C +260°  
F +500°

C +400°  
F +752°

C +538°  
F +1000°

C +650°  
F +1200°

<p><b>24 series</b> 1 or 2 Piece (one is welded) Class 2500 1/4" - 1 1/2" DN8-DN40</p>	<p><b>27 series</b> 3 Piece Class 2500 1/4" - 2" DN8-DN50</p>	<p><b>28 series</b> 3 Piece Class 2500 1/4" - 8" DN8-DN200</p>	<p><b>96 series</b> Trunnion Class 2500 8" - 10" DN50-DN200</p>	<p><b>Z28 series</b> 3 Piece Class 2500 1/4" - 1 1/4" DN8-DN32</p>	<p><b>Z96 series</b> Trunnion Class 2500 8" - 10" DN50-DN250</p>	<p><b>Z28T series</b> 3 Piece Class 2500 1/4" - 1 1/4" DN8-DN32</p>
<p><b>27 series</b> 3 Piece Class 1500 2 1/2" - 8" DN65-DN200</p>	<p><b>95 series</b> Trunnion Class 1500 2" - 12" DN50-DN300</p>			<p><b>Z28 series</b> 3 Piece Class 2500 1 1/2" - 6" DN40-DN150</p>		<p><b>Z28T series</b> 3 Piece Class 2500 1 1/2" - 6" DN40-DN150</p>
<p><b>47X/W/G series</b> 3 Piece Class 900 1/4" - 2 1/2" DN8-DN65</p>	<p><b>94 series</b> Trunnion Class 900 2" - 16" DN50-DN400</p>				<p><b>Z95 series</b> Trunnion Class 1500 2" - 12" DN50-DN300</p>	
<p><b>26X/W series</b> 3 Piece Class 600 2" - 8" DN50-DN200</p>	<p><b>61/62 series</b> 3 Piece - Multiport Class 600 1/2" - 1 1/2" DN15-DN40</p>	<p><b>93 series</b> Trunnion Class 600 2" - 16" DN50-DN400</p>		<p><b>Z47 series</b> 3 Piece Class 600 1/4" - 2" DN8-DN50</p>	<p><b>Z94 series</b> Trunnion Class 900 2" - 12" DN50-DN300</p>	<p><b>Z47T series</b> 3 Piece Class 600 1/4" - 2" DN8-DN50</p>
<p><b>48X/G series</b> 3 Piece - TrueBore Class 300 1/2" - 6" DN15-DN150</p>	<p><b>83 series</b> Trunnion Class 600 2" - 16" DN50-DN400</p>	<p><b>D31/S31/D32/S32 series</b> Diverter Class 150/300 1/2" - 8" DN15-DN200</p>			<p><b>Z91/92/93 series</b> Trunnion Class 150/300/600 2" - 12" DN50-DN300</p>	<p><b>Z47T series</b> 3 Piece Class 600 1 1/2" - 6" DN40-DN150</p>
<p><b>32X/W/G series</b> 1 Piece Class 300 1/2" - 8" DN15-DN200</p>	<p><b>47X/W/G series</b> 3 Piece Class 400 3" - 6" DN80-DN150</p>	<p><b>61/62 series</b> 3 Piece - Multiport Class 300 2" - 4" DN50-DN100</p>	<p><b>D47/S47 series</b> 3 Piece - Diverter Class 600/300 1/4" - 6" DN8-DN150</p>	<p><b>81/82 series</b> 2 Piece Class 150/300 2" - 16" DN50-DN400</p>	<p><b>Z47 series</b> 3 Piece Class 600 2 1/2" - 8" DN65-DN200</p>	<p><b>Z74 series</b> 2 Piece Class 300 1/2" - 8" DN15-DN200</p>
<p><b>74X/W/G series</b> 1 Piece Class 300 1/2" - 1" DN15-DN25</p>	<p><b>74X/W/G series</b> 2 Piece Class 300 1 1/2" - 8" DN40-DN200</p>	<p><b>78X/W/G series</b> 1 Piece PN 40 1/2" - 1" DN15-DN25</p>	<p><b>78X/W/G series</b> 2 Piece PN 40 1 1/2" - 2" DN40-DN50</p>	<p><b>91/92 series</b> Trunnion Class 150/300 2" - 16" DN50-DN400</p>	<p><b>Z78 series</b> 2 Piece PN 40 1/2" - 2" DN15-DN50</p>	<p><b>Z74T series</b> 2 Piece Class 300 1" - 8" DN25-DN200</p>
<p><b>31X/W/G series</b> 1 Piece Class 150 1/2" - 8" DN15-DN200</p>	<p><b>73X/W/G series</b> 2 Piece Class 150 1/2" - 8" DN15-DN200</p>	<p><b>77X/W/G series</b> 2 Piece PN 16 3" - 8" DN80-DN200</p>			<p><b>Z73 series</b> 2 Piece Class 150 1/2" - 8" DN15-DN200</p>	<p><b>Z77 series</b> 2 Piece PN 16 3" - 6" DN80-DN150</p>
					<p><b>Z78T series</b> 2 Piece PN 40 1" - 1 1/2" DN25-DN40</p>	<p><b>Z78T series</b> 2 Piece PN 40 2" DN50</p>
					<p><b>Z73T series</b> 2 Piece Class 150 1" - 8" DN25-DN200</p>	<p><b>Z77T series</b> 2 Piece PN 16 3" - 6" DN80-DN150</p>

# HERMETIX™

## ZERO leak stem seal

### Standard valve series

Habonim standard product lines cover a wide range of sizes and pressure classes, with countless variations of materials and designs to support global industrial demands. Habonim has a reputation for fast and reliable delivery of all its standard valve series products. One of the unique features that Habonim provides to the industry in all its standard product lines is the revolutionary HermetiX™ stem seal (Habonim design patent).

### HermetiX™

Habonim standard valves, including the HermetiX™ stem seal, passed the severe type test dictated by the ISO 15848-1 and API641 with great success. Third party certifications for the complete standard product line are published for the convenience of Habonim customers. The HermetiX™ stem seal is named for its distinctive "X" shaped design. The flexible "X" shape creates a dynamic sealing arrangement that allows the HermetiX™ stem seal to adjust itself as pressure builds. In the event of a pressure buildup or side load, the stem seal dynamically adjusts to prevent fugitive emissions, making HermetiX™ a superior design compared with the conventional flat stem seals currently available on the market.

The HermetiX™ stem seal also includes a tough thrust bearing (CF PEEK by default) located between the stem and the valve body, and an anti-abrasion ring (CF PEEK by default) located between the soft HermetiX™ stem seal and the stainless steel follower. Both elements minimize erosion and loss of preload, thus keeping the stem components in their original condition and extending their service life up to 500 thousand cycles.

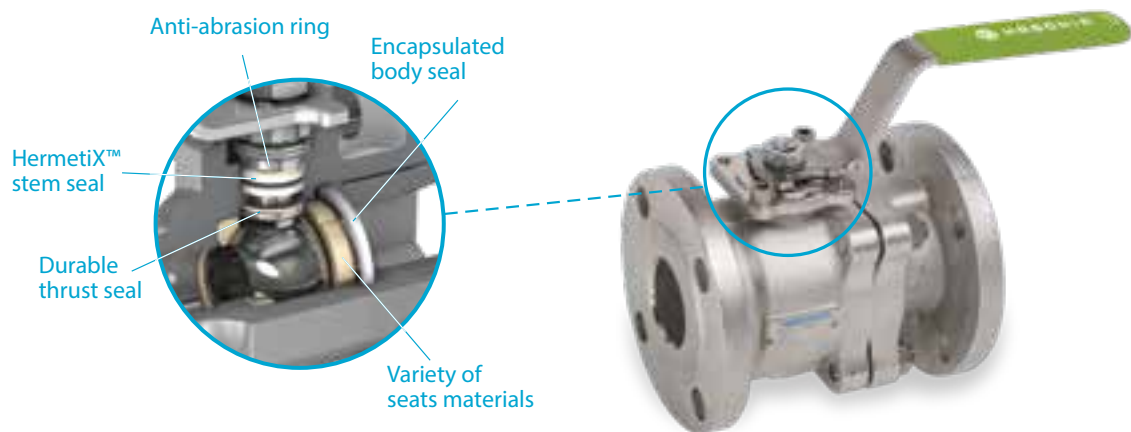

### Series in range

47X series up to Class 900  
31X/32X series - Class 150/300  
73X/74X series - Class 150/300  
77X/78X series - PN16/PN40  
48X series - Class 300  
61X/62X series - Class 300  
26X series - Class 600  
24X series - Class 2500  
27X series - Class 2500  
28X series - Class 2500

### Features

- Fugitive emission certified to ISO 15848-1 and API641
- Minimizes shutdowns for maintenance up to 500,000 cycles
- Ensures uninterrupted production
- Anti-static as standard
- Habonim design Patent No. D598,988

# HERMETIX™ FIRE SAFE

## Durable fire safe stem seal

Today, there is an ever increasing demand for quality fire safe valves due to a number of factors, which include: rising insurance costs for liability due to personal injury or loss of life, property damage, tighter environmental and safety regulations, loss of materials through leakage, and the high cost of system shutdown. Continued development of the HermetiX™ technology led to Habonim's revolutionary durable fire safe stem seal design. A polymer based stem seal and a unique trim construction holds the stem aligned and preloaded even after a fire.

The durable fire safe stem seal is suitable for use in hazardous industries like chemical, petrochemical and oil & gas applications, where it improves the performance of the valve stem seal up to 500 thousand cycles compared to a conventional porous graphite stem seal. The HermetiX™ fire safe valve offers the ultimate solution; an exclusive durable stem seal that eliminates the risk of graphite disintegration after prolonged stem wear which protects both line media and air quality.

### Series in range

F47W series up to Class 900  
F31W/F32W series - Class 150/300  
F73W/F74W series - Class 150/300  
F77W /F78W series - PN16/PN40  
F26W series - Class 600  
F24W series - Class 2500  
F27W series - Class 2500  
F28W series - Class 2500

### Unique features

- Fire safe certified to API 607 and ISO 10497
- Minimizes shutdowns for maintenance up to 500,000 cycles
- Increases site safety



## HERMETIX™ zero contamination fire safe valve

This unique fire safe valve design specially designed for the biopharm industry includes the HermetiX™ stem seal consisting of a virgin PEEK thrust bearing and anti-abrasion ring, and a stem seal made of TFM material. Both virgin PEEK and TFM are FDA approved. A double body seal set is comprised of an internal PTFE body seal facing the media, and an external graphite seal to withstand the fire. This configuration effectively isolates the graphite seal in a dry cavity, preventing it from coming in contact with the media, ensuring a high level of purity for the valuable media.

### Series in range

F47G series up to Class 900  
F48G series - Class 300  
F31G/F32G series - Class 150/300  
F73G/F74G series - Class 150/300  
F77G/F78G series - PN16/PN40

### Unique features

- Zero contamination fire safe construction
- Prevents media contamination from graphite particles
- FDA approved soft parts
- Cleaned assembled and packed for oxygen service
- Animal Derivative Free (ADF) assembly



# TrueBore™ 48 Series

The TrueBore line is Habonim's sanitary ball valves for the Biotech industry. The valves comply with the ASME BPE standard for applications in which cleanability and drainability are essential for product quality.

The standard, highly durable stem seal for all TrueBore valves is Habonim's patented HermetiX™ stem seal, made solely from FDA-approved polymer materials, the HermetiX™ stem seal enhances productivity and safety by virtually eliminating leaks, shutdowns, hazardous spillage, etc.

The TrueBore comes with a maintenance-free warranty of 4 years or 500,000 cycles.

The valve port diameter is identical to the tube inner diameter so that no expansion or contraction can take place inside the system, resulting in full drainage and zero traces that could cause contamination.

To provide superior welding quality, to avoid rouging on austenitic stainless steel surfaces, and corrosion attack on welding areas, The TrueBore metal parts are defined, as standard, with low ferrite (FE < 2%) and controlled sulfur (0.005% < S < 0.017 %). Upon request a forged 316L stainless steel material with ferrite content less than 1% is also available.

## Technical summary

<b>Size range</b>	½"- 6" (DN15 - DN150)
<b>Pressure range</b>	Vacuum 10 <sup>-6</sup> superscript Tor to 50 bar (750 psi)
<b>Temperature range</b>	-60 °C to +230 °C (-76 °F to +446 °F)
<b>Materials</b>	Stainless steel A351 CF3M, A479 316L, EN 10222-5 1.4435, Alloy C22
<b>End connections</b>	Extended tube ends for in-line orbital welding, clamp connection
<b>Operation</b>	Lever or gear operated, pneumatic or electric actuation
<b>End connections</b>	Pharmaceutical , bioprocessing, cosmetics, food & beverage

## 48X series TrueBore with ISO 15848-1 and API641 certified stem seal

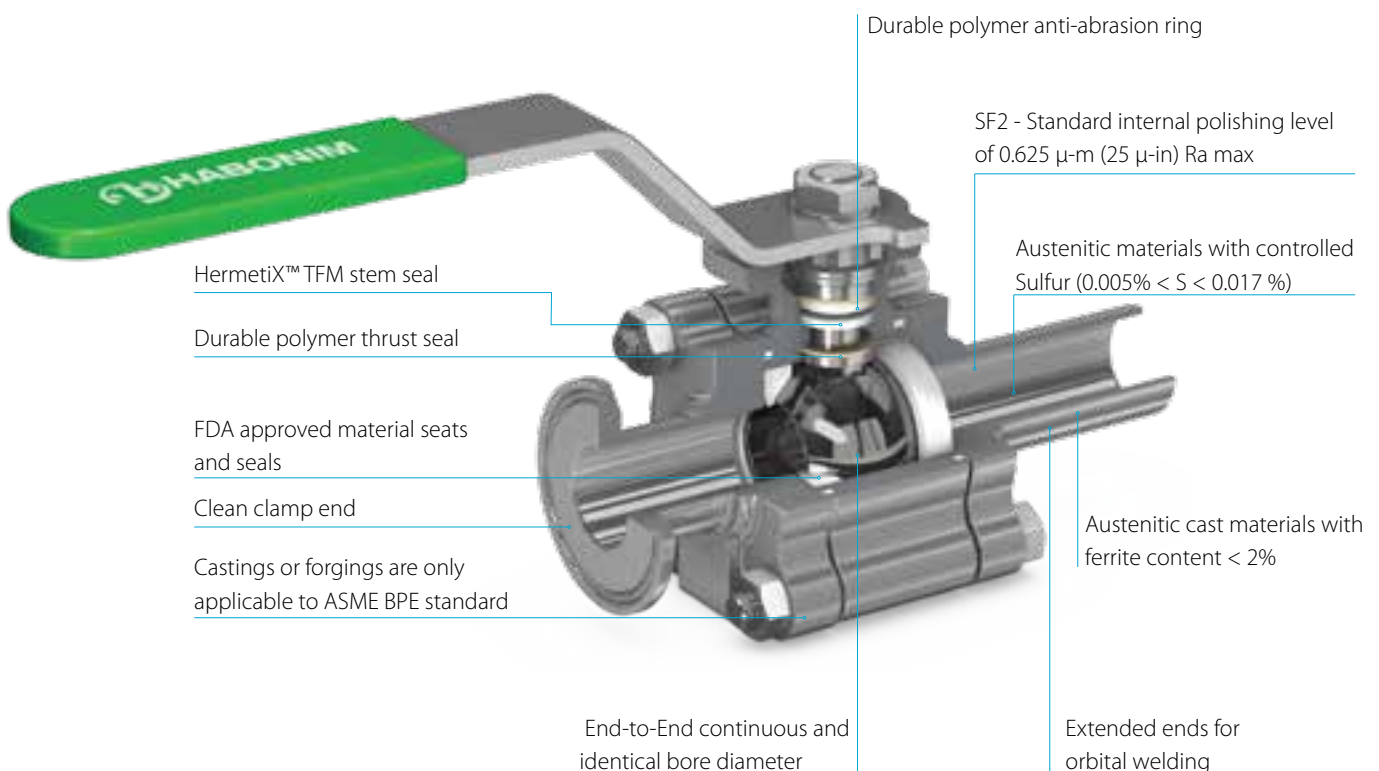



## Features

- Full compliance with ASME BPE standard.
- ISO 1127 and DIN11850 TrueBore(TM) bar made valves are available.
- Maximum flow capacity, full drainage.
- Low-torque and bubble tight shutoff capabilities.
- Certified for fugitive emission to ISO 15848-1 and API641 standard.
- Stem seal maintenance-free warranty of 4 years or 500,000 cycles.
- Forged 316L stainless steel material with low ferrite (FE < 1%), and controlled sulfur ( $0.005\% < S < 0.017\%$ ) are available.
- Materials (EN 10222-5 1.4435 (316L) and A494 CX-2MW Alloy C22) are available upon request.
- Valve internal surface mechanically polished to 25  $\mu$ -in Ra max as standard. Higher surface finishes up to 20  $\mu$ -in Ra (max) available upon request, as well as electro-polishing of valve body and ends.

## Cleaning, Assembly, Testing and Packaging

Habonim's meticulous cleaning, assembly and inspection procedure for the TrueBore line ensures the stringent cleanliness required by Biotech services.

All particles, grease, metal chips and other contamination hazards are removed thoroughly before the assembly process begins. The valves are assembled in an oil free restricted area by specially trained & qualified personnel.

All valves are 100% helium leak tested. Packaging is done in the same cleanroom where the cleaning process was completed. Finished (dry, completed, inspected and approved) valves are removed from the cleanroom environment only after being bagged and sealed in a clean polyethylene bag.



# CRYOGENIC VALVES

In light of the increasing demand for alternative sources of clean energy, Habonim's double sealed Cryogenic Ball Valve is certain to ensure Habonim's position in the forefront of the energy market. Under extremely low temperatures and in the harshest of environments, Habonim products consistently exhibit high flow capacity, tight shutoff, energy efficiency and long service-free life. The result is a product unmatched in reliability, stability and most importantly, safety. Habonim's cryogenic valves are used in air separation plants, LNG storage, distribution and transportation, aerospace, petrochemical and medical industries.

## Technical summary

<b>Size range</b>	¼"-8" (DN8-DN200)
<b>Series in range</b>	C47 - up to Class 600 C31/C32 - ANSI series - Class 150/300 C73/C74 series - ANSI Class 150/300 C78 series - PN40 C77 series - PN16 C28 series - up to Class 2500 C26 series - Class 600
<b>Pressure range</b>	Vacuum 10 <sup>-6</sup> Tor to 414 bar (6000 psi)
<b>Temperature range</b>	-269 °C to +200 °C (-452 °F to +392 °F)
<b>Materials</b>	Stainless steel A351 CF8M/CF3M, A479 316/316L, monel 400 and more
<b>End connections</b>	Threaded, welded, flanged

## Features

### Efficient heat transfer

- Narrow space between extension ID and stem OD allows the stem seal to remain at ambient temperature

### Bonnet installation angle

- Up to 45° from vertical allowed for the 12" bonnet (fully BS6364 compliant)
- Up to 15° from vertical allowed for the 6" bonnet (not BS6364 compliant)

### Stem seal

- HermetiX™ ISO 15848-1 and API641 certified
- HermetiX™ fire safe - durable stem seal
- API 607 and ISO 10497 certified
- High endurance up to 500 thousand cycles
- Anti-abrasion mechanism
- Live loaded

### Body seals

- Double seals body and bonnet (26 & 28 series excluded)

### No trapped cavity

- Relief hole on the upstream sphere of the ball to prevent pressure buildup in the cavity

### Minimum thermal expansion

- Double amount of body bolts
- One size up short body bolts
- Additional spring washers

### Stem

- 'Blow-out' proof
- Solid one-piece stem
- Tight stem-to-ball engagement
- High torque durability

### Pressure containing parts connection

- Fail safe assembly
- Integral rib and asymmetric groove ensures correct assembly

### Tongue & groove labyrinth design

- Zero leakage to the atmosphere
- Full compression of encapsulated body seal
- Accurate alignment of all parts

### Flow direction indicators

- Highly visible arrows on body and bonnet top
- "T" mark on the stem, showing relief hole direction

# HERMETIX™ fire safe

## Series in range

FC47W/G series up to Class 600

FC31W/G / FC32W/G series - Class 150/300

FC73W/G / FC74W/G series - Class 150/300

FC77W/G / FC78W/G series - PN16/PN40

FC26W series - Class 600

FC28W series - Class 2500

## Features

- Zero Particle risk in liquid oxygen
- Increases site safety



# METAL SEATED VALVES

Habonim's metal seated valve excels in the harshest industrial environments, where valve failures can damage plant efficiency, reduce profitability and endanger safety. Habonim's metal seated valve is designed to withstand the hardest applications and process conditions, combined with extreme high temperature, high pressure and abrasive medium.

The lower temperature range, from -60°C (-76°F) to 400°C (752°F), is designed with Habonim's unique surface treatment, the LTPCN (Low Temperature Plasma CarboNitriding). LTPCN is a cost effective hardening system for austenitic stainless steel, which provides a minimum thickness of 40 microns and more than triple (>68HRC) the natural hardness of the base material for the ball and seats and seats undergo the LTPN process.

For the higher temperature range, from 400°C (752°F) and up to 650°C (1200°F), Habonim offers various HVOF spray solutions based on chromium and tungsten carbides. For the severe abrasive condition of the pulp and paper industry, Habonim offers a minimum of 1.5 mm thick, hard stellite coating. Each coating is specifically engineered to the customer's application in order to provide outstanding resistance to abrasion and corrosion for a lifetime of effective operation in harsh applications.

Each ball and seat subassembly is accurately machined, ground and finally mate-lapped for a perfect match. The complete valve assembly demonstrates high repeatability in terms of sealing (Rate A – factory tested), low torque and smooth operation at various temperatures and pressures.

## Technical summary

<b>Size range</b>	¼"- 8" (DN8-DN200)
<b>Series in range</b>	47Z / T47Z series (up to Class 900) 73Z / T73Z / 74Z / T74Z series (Class 150/300) 78Z / T78Z / 77Z / T77Z series (PN16/PN40) 28Z/ T28Z series (up to Class 2500)
<b>Pressure range</b>	Vacuum 10 <sup>-6</sup> Tor to 414 bar (6000 psi)
<b>Temperature range</b>	-60 °C to 650 °C (-76 °F to 1200 °F)
<b>Materials</b>	Stainless steel A351 CF8M/CF3M, A479 316/316Ti Carbon steel A350 LF2, A216 WCB ,A105, Duplex, Super duplex, 254SMO
<b>End connections</b>	Threaded, welded, flanged

## Features

### Safety

- Anti static fire-safe design
- Tongue & groove design ensures accurate alignment of body and end connections resulting in zero leakage to the atmosphere

### Robust trim design

- Live loaded stem seal assures zero emission
- 'Blow-out' proof design
- One piece solid stem design
- Tight stem-to-ball engagement
- High torque durability
- Rigid one piece stem extension for extreme applications

### Metal ball and seat mechanism

- Absolute shutoff achieved by perfect lapping process of ball and metal seats set
- Low Temperature Plasma CarboNitriding (LTPCN) to withstand corrosion and temperature up to 400 °C
- Surface treatments and coatings to withstand abrasion resistance
- Preloaded ball/seats set

### Minimum thermal expansion

- Double amount of body bolts
- One size up short body bolts

### Flow direction indicators

- High visibility arrows showing flow direction

## Low Temperature CarboNitriding - LTPCN

Habonim's unique LTPCN - "Low Temperature Plasma CarboNitriding" treatment improves mechanical wear properties of austenitic stainless steels, without affecting their corrosion resistance.

Austenitic stainless steels have excellent chemical resistance to corrosion, and are used extensively in a variety of environments and industries including oil & gas, marine, medical, chemical and petrochemical. The use of these steels is limited however, due to their low wear resistance, low hardness and the chance of galling. Conventional heat treatments, such as nitriding are very effective in providing metallic surfaces with high wear resistance, but these standard processes come at a cost, as they decrease corrosion resistance. Limiting the heat treatments' temperature to less than 450°C forms a supersaturated layer having excellent wear resistance, while at the same time preserving the stainless steel's corrosion resistant properties.



LTPCN in process



A production batch after LTPCN treatment

## The Ideal Solution for Severe Applications up to 400 °C (752 °F)

Habonim's LTPCN treatment offers the solution for austenitic stainless steels by improving mechanical wear properties without affecting corrosion resistance. The LTPCN process is performed at temperatures of 400°C (752°F) to 450°C (842°F) in pulsed DC plasma, and produces a significant hardening effect on the surface of austenitic stainless steels. During the process, atoms of carbon and nitrogen diffuse interstitially into the metal, producing carbon and nitride layers of more than 40µm thick having a micro-hardness of 68 to 75HRC, compared with a hardness of no more than 25HRC of the parent material. As a result, the wear resistance of the stainless steel is improved while at the same time, its corrosion resistance is preserved. Moreover, because of the low temperature of the process, there are no changes in the shape or size of the LTPCN treated parts.



# HIGH PRESSURE VALVES

The Habonim high pressure valve series is based on a floating ball valve technology, specially built for endurance and reliability with a design pressure of up to ANSI Class 2500 (414 bar / 6,000 psi). As standard, the high pressure series is made from forged or rolled bar material. Consequently we are able to 'sculpture' the valve to customer specific demands in a very short time. The result is a cost effective solution compared with trunnion mounted ball valve technology. The high pressure valve series delivers reliable performance in the most demanding applications in the oil & gas, offshore drilling platform, petrochemical and the power industries.

The 28 series can handle differential pressure of up to 200 bar (2900 psi) providing smooth and trouble free operation. The pressure containing parts are in compliance with ASME B16.34, in all aspects, the design successfully passed burst testing according to DNV rules, i.e. holding four times the pressure rating for 5 minutes. A one-size-up stem made of high tensile material complies with ASME B16.34 and API 6D for drive train requirements provides sufficient safety factor during operation. A special hybrid seat design is comprised of a metal housing and polymer insert machined as a single unit. This provides higher metal seat stiffness and bubble tight shut-off (Rate A) combined with lower operating torque compared to any equivalent valve solution.

The 27 series is a cost effective solution compared with the 28 series when the application allowable differential pressure of the application does not exceed 70 bar (985 psi) for valve size 2" (DN50) and above.

The 24 series is part of the Habonim high pressure instrumentation line, a two-piece design, in sizes up to 1½" (DN40). The 24 series is DNV certified, having successfully passed burst testing as well as fire safe testing to API 607 and ISO 10497. By default the valve is manually operated, automation is available upon request.

## Technical summary

<b>Size range</b>	¼"- 8" (DN8-DN200)
<b>Series in range</b>	28 series up to Class 2500 27 series up to Class 2500 24 series - Class 2500
<b>Pressure range</b>	Vacuum 10 <sup>-6</sup> Tor to 414 bar (6000 psi)
<b>Temperature range</b>	-60 °C ÷ +260 °C (-76 °F ÷ +500 °F)
<b>Materials</b>	Stainless Steel 316L, Carbon Steel, ASTM A350 LF2
<b>End connections</b>	Threaded, welded, flanged

## Features

### Body

- Robust high pressure design
- Full compliance with B16.34 (wall thickness) and API 6D
- Fire safe certified to API 607 / ISO10497
  
- ISO 15848-1 and API641 Certified for fugitive emission
- High endurance up to 500 thousands of cycles
- Firesafe certified durable stem seal

### Seats and seals

- Rate A leakage tightness

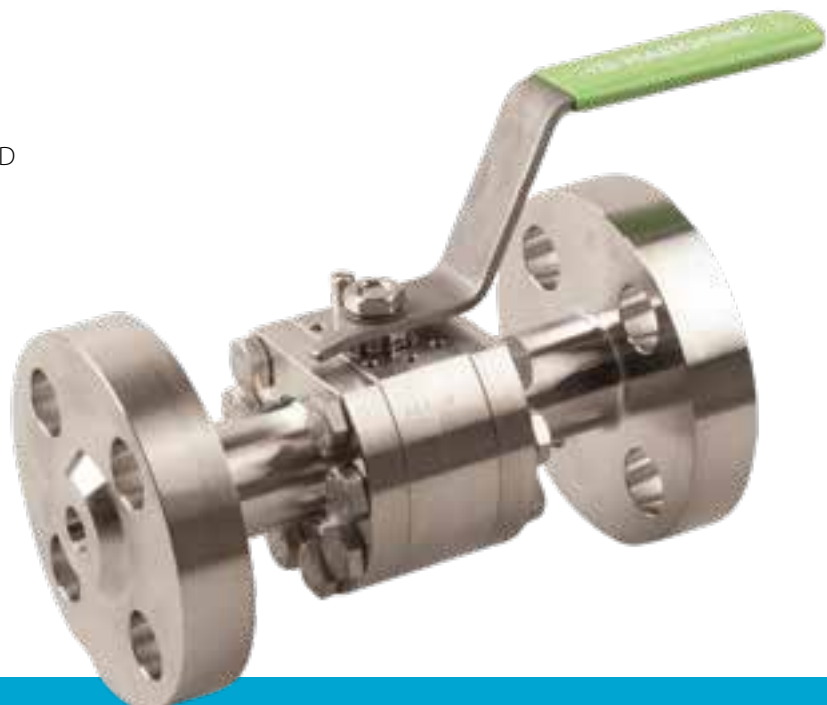

# TRUNNION MOUNTED BALL VALVES

The Habonim trunnion mounted valve series is specially design to endure the harsh conditions of the oil & gas and petrochemical industries, including both underground and above ground installation. The robust design tolerates the heavy loads applied to the valve trim that result from combinations of large sizes, high pressures and temperature cycles. The trunnion valve series is certified to API 6D (Habonim monogram #6D-1278) with a valve wall thickness that is in full compliance with ANSI B16.34.

The complete line is fire safe designed according to API 607, ISO10497 and API 6FA.

Up to class 600, Habonim offers a cost effective solution consisting of a 2-piece solid cast full port valve; while with class 900 (94 series), class 1500 (95 series) and class 2500 (96 series), Habonim uses a robust 3-piece forged design for body and ends.

The trunnion valve line is operable under the full differential ANSI class pressure rating, by applying manually a maximum operating force of 360N (80 lbf). A variety of end connectors allows design flexibility according to customer needs.

## Technical summary

<b>Size range</b>	2" - 16" (DN50 - DN400)
<b>Series in range</b>	91 series - Class 150/PN20 92 series - Class 300/PN50 93 series - Class 600/PN100 94 series - Class 900/PN160 95 series - Class 1500/PN250 (up to 12") 96 series - Class 2500/PN400 (up to 8")
<b>Pressure range</b>	Vacuum $10^{-6}$ Tor to 414 bar (6000 psi)
<b>Temperature range</b>	-60 °C (-76 °F) to 260 °C (418 °F).
<b>Materials</b>	Carbon Steel A350 LF2, ,A105, A216 WCB, Stainless Steel 316/316L and more
<b>End connections</b>	Welded, flanged

## Features

- Double block & bleed
- API 6D certified (API monogram #6D-1278)
- Fire safe designed to API 6FA, API 607, ISO 10497
- Blowout proof stem design
- Corrosion resistant low friction bearings
- Double or single piston-effect seat design
- Inconel springs, assist in low pressure sealing
- Stainless steel injection fittings for emergency stem or seat sealant & lubrication maintenance
- NACE MR0175/ISO 15156
- Integral top-works direct mounting pad
- Bi-directional
- 8" and larger valves are equipped with lifting lugs
- Antistatic grounding between ball, stem & body
- Vent and drain valves



# PNEUMATIC COMPACT ACTUATOR

## Proven advantage

The COMPACT actuator is a quarter-turn rack & pinion pneumatic actuator that doubles the torque of standard pneumatic actuators. The superior performance is achieved by Habonim's patented four piston design, which generates torque around a centrally located piston. This translates into double the power for the same size actuator or half the size for the same amount of power.

## Space saving, fast acting

The COMPACT has four small cylinders, one located on each of the four sides of the cube. The smaller pinion and shorter travel distance of the pistons in the COMPACT require less air pressure than a larger double-piston actuator does to produce the same torque output. The end result is faster response times for emergency shutdown, lower air pressure for operation and reduced maintenance.

## Technical summary

<b>Pressure range</b>	1.5 - 8 bar (20-120 psi) for DA actuators 2- 8 bar (30-120 psi) for SR actuators
<b>Size range</b>	C15, C20, C25, C30, C30M, C35, C35M C45, C45M, C60, C60M, C75, C75M
<b>Ambient temperature</b>	NBR -20 °C to 80 °C (-4 °F to 176 °F) Viton -20 °C to 120 °C (-4 °F to 250 °F) EPDM -40 °C to 80 °C (-40 °F to 176 °F) LT NBR FX428 -60 °C to 100 °C (-67 °F to 213 °F)
<b>Compressed gas</b>	Air, Nitrogen, CO <sub>2</sub> , Natural gas (sweet)

## Features

- Light weight & small volume
- Balanced forces
- Less wear
- Superior corrosion resistance
- Less air consumption
- Fast action
- Single acting (spring return) and double acting configurations
- High efficiency





# IMPACT™ SPRING ASSIST

The IMPACT™ spring assist is a pneumatic device whose purpose is to increase spring closing torque on spring return actuators. This is achieved by diverting air pressure from the inner chamber to the spring chambers so that in combination with the spring force an increase in the total closing torque of the actuator is achieved. Redirecting the air pressure into the spring chamber increases the spring end torque by 50% and more.

## Features

- Boost the torque of any spring return actuator
- One size down actuator for the same functionality
- Increase system reliability
- Internal breather block
- No external energy required
- NAMUR interface
- Single mechanical unit



# BREATHER BLOCK

In many applications where the environment is corrosive or polluted, it is necessary to protect the actuator spring chambers and internals from sucking in external air during operation. The new NAMUR Breather Block prevents suction of external air into the spring chambers. This is achieved by redirecting the instrumentation air that is supplied to the actuator's spring chamber during the spring stroke thus preventing external air from being sucked in. The Breather Block exhaust port has a filter which prevents infiltration of foreign substances and can also be fitted with a speed controller.

## Features

- Extended life in harsh service
- Maintenance free
- Isolates the actuator from the surroundings
- Operating limits: pressures up to 10 bar (150 psi) and temperature range of -20 °C to +85 °C (-4 °F to +185 °F)



# CONTROL VALVES

Habonim Control Valves are designed to meet industrial demands for flow control systems, that are accurate, flexible, cost efficient and easily maintained. The valves provide excellent performance, even in the harshest environments, offering a compact lightweight design solution.

step-less characterized by step-less pressure and flow control for fast response times, wide range ability, zero backlash and bubble-tight shutoff. Critical features include high pressure drop capacity with straight through flow, high Cv, and additional design features for ease of maintenance and zero backlash.

## Technical summary

<b>Size range</b>	¼" - 8" (DN8 - DN200)
<b>Series in range</b>	N47 series - Class 900 N31/N32 series - Class 150/300 N78 series - PN40 N77 series - PN16 N73/ N74 series - Class 150/300
<b>Pressure range</b>	Vacuum 10 <sup>-6</sup> Tor to 155 bar (2250psi)
<b>Temperature range</b>	-196 °C to +320 °C (-320 °F to +608 °F)
<b>Materials</b>	Stainless steel A351 CF8M/CF3M, Carbon steel A216 WCB, A105, Duplex, Super duplex, 254SMO and more
<b>End connections</b>	Threaded, welded, flanged

## Features

- Less stem seal wear
- Small size, light weight
- Less cavitation damage
- High recovery
- Various surface treatment and coatings
- Wide rangeability
- High repeatability
- Zero backlash
- Easy to maintain



# AUTOMATED PACKAGE

## PNEU-LINK

The Habonim Pneu-link modulating system is the first quarter turn ,rack & pinion control unit to pass the 'Black Diamond Test' several times with high rating.

The Pneu-link is designed to eliminate the need for a traditional mounting kit, tubing and fittings, replacing it with a rigid manifold connection using O-ring sealing and a firm bolting connection. This results in a low profile compact package, minimum leak path, zero air leaks, and a unit impervious to harsh surroundings.

The Pneu-link valve actuator mounting kit includes a 'zero backlash, coupler and lock-in-place on/off position to meet the latest OSHA requirements.

The Pneu-link includes an advanced air manifold linkage specifically engineered for the Habonim 4-piston pneumatic actuator and to a variety of accessories such as the Stonel Axiom limit switch box, PMV D3 and PMV EP5 electro-pneumatic positioners. Its corrosion resistant design makes it ideal for harsh wash down environments such as pharmaceuticals, food and beverage and corrosive environments. The Habonim COMPACT actuator is available as epoxy powder coated aluminum or nickel plated for extreme corrosive applications. Additionally, The switchbox is available with a nickel plated housing and either a Lexan or nickel plated aluminum cover for extreme corrosive applications.

### Features

#### Fire safety

- Fusible plug
- Exhaust in case of fire
- Fail-safe

#### Direct mounting kit

- Internal air porting
- No external hose connections
- Increased rigidity and durability
- Low profile
- Small footprint
- Minimum leak path
- Zero air leak

#### 4 - Piston COMPACT Pneumatic actuator

- Minimum hysteresis
- Zero backlash

#### Lockable mounting kit

- Maintenance safe
- High repeatability
- One piece rigid cast bracket



# Dual-safe valves

## The Dual-Safe Solution

The Habonim Dual-Safe valve series presents an optimal design solution and guarantees isolation on critical applications and service when an emergency shut-down (ESD) valve is a necessity. The Dual-Safe unit incorporates two main isolation valves and one bleed valve in a single body construction. This special construction offers the lowest possible number of potential leakage points from a process connection and reduces the overall valve envelope size and weight by integrating valves, piping, and fittings into one compact design.

## Prevention of explosions in fuel, oil and natural gas furnaces

Furnace explosions are caused by the ignition of an accumulated combustible mixture within the boiler furnace enclosure. An interruption of the fuel or air supply or ignition energy to the burners, sufficient to result in momentary loss of flames, followed by restoration and delayed reigniting of an accumulation. Repeated unsuccessful attempts to light off without appropriate purging can result in an accumulation of an explosive mixture. Fuel leakage into an idle furnace and the ignition of the accumulation by a spark or other source of ignition. Explosions, including “furnace puffs”, are the result of improper equipment design, improper procedures by operating personnel or control system malfunctions.



## How Dual-Safe works

The two main isolation valves are operated by one actuator with a coupled mechanical link system that ensures they rotate together. The bleed valve is actuated separately. This unit presents a simple concept that will assure zero flow to the furnace and maximum operational safety

### Standard operation

In a standard application, the primary line valves are set to the “fail to close” position, and the bleed valve is set to the “fail to open” position. During normal operation, the primary line valves are open; the bleed valve is closed, and gas flows to the furnace.

### Shutting down

When shutting down the system, the isolation valves are closed, while the bleed valve is switched to its open position. A pipeline connected to the bleed valve releases the trapped pressure between the two isolation valves out into the atmosphere. Any trace of leakage detected between the isolation valves triggers a sensor on the bleed line and sets off an alarm in the control room.

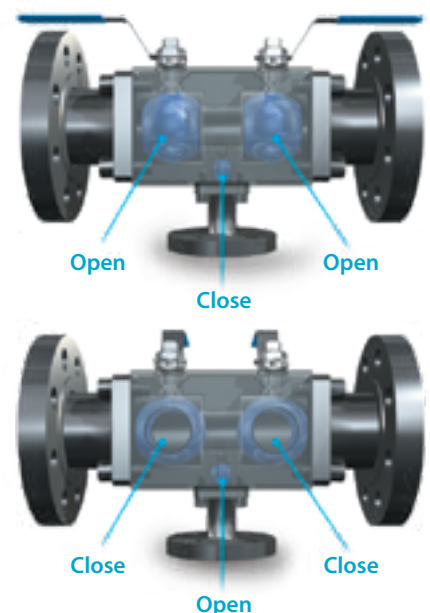

---

## Dual-Safe features

- Minimizes the risk of furnace explosion.
- Increases system reliability.
- Saves space and reduces weight.
- Reduces installation time.
- Streamlines maintenance operations.
- Reduces number of items in repair kits.
- Rugged construction.
- Bubble tight shutoff on all three valves.
- Coupled operating mechanism reduces the number of actuators on the main line
- Tongue and groove design for all body seals Variety of end connections (welded, threaded, flanged)



# Inspired By Challenge

Habonim excels when no commercial product can satisfy your requirements. Habonim's experienced engineering and R&D team frequently creates special solutions that meet the needs of special customer requests. To name a few:

- Complex skids and automated manifold designs, which fully comply with your P&ID
- Lower weight and reduced volume of existing systems for off-shore applications
- Minimizing leak paths and introduction of fail-safe assemblies in hazardous applications.
- Fast closing (<0.5 sec) automated mechanism for ESD systems
- Safety shut-off device for gas feeding systems

We create custom valves, manifolds and special solutions to meet the most stringent demands of extreme temperature, high pressure, corrosive and abrasive application, because at Habonim we are "inspired by challenge"

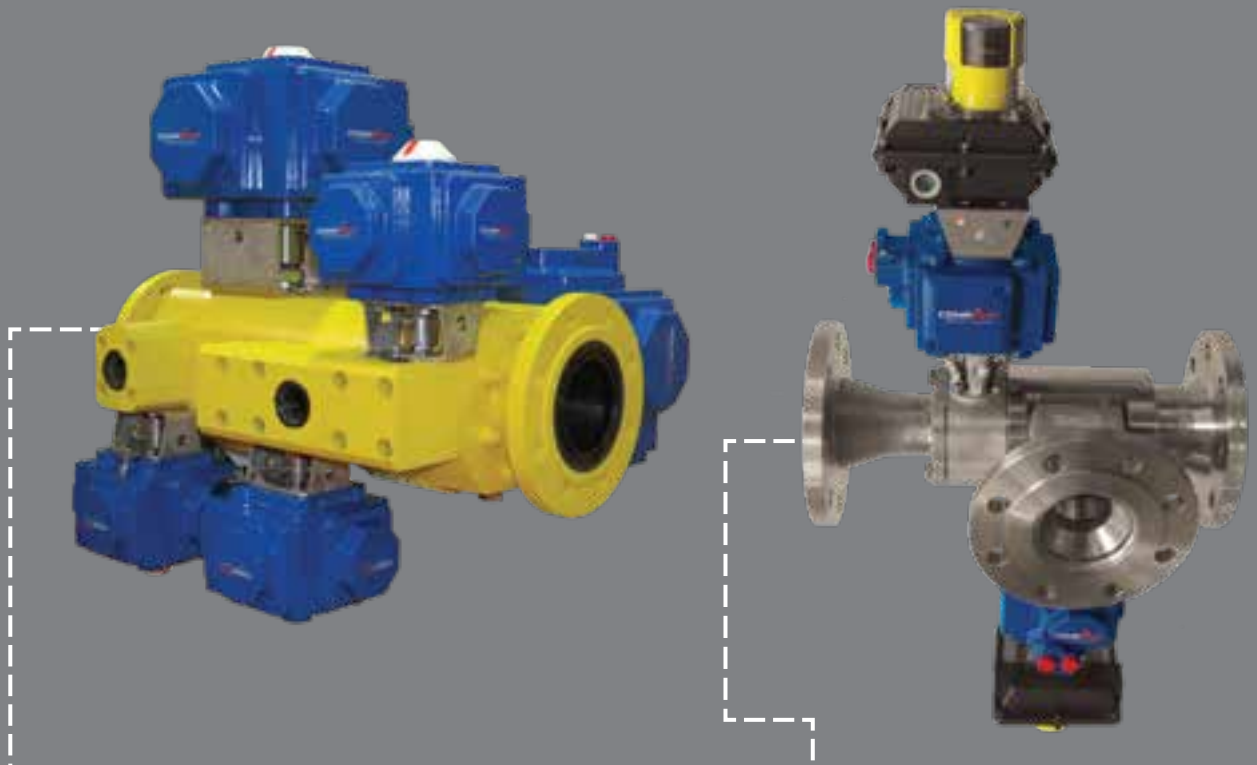

## Gas Valve Unit (GVU)

Special manifold for dual fuel (diesel / LNG) ships reduce the amount of pollution generated by ship engines. Increase air quality in harbor cities.

## Cost-Effective Replacement Solutions

A custom valve used for Diverting flow from a single source to multiple lines was designed to replace larger globe valves for the same application.



### **Cryogenic double block & bleed valve**

Habonim's cryogenic DBB valve maximizes safety when handling high-pressure cryogenic liquids at the most critical stages of LNG and CNG processing that require a furnace feed (boiler, gas turbine, LNG or CNG feeder). The Habonim cryogenic DBB valve solution is comprised of a single body, which saves space and reduces the number of body seals, thereby reducing the potential for leakage.

### **Multi-valve ensemble (MVE)**

Habonim designed the revolutionary Multi-Valve-Ensemble (MVE) as an innovative alternative to large, heavy skid-mounted valve assemblies that take up so much space and are loaded down with complex piping; vulnerable to leakage. The MVE eliminates up to 90% of the piping required on conventional skids, and weighs 30% less.



www.habonim.com

**Habonim USA**

Toll Free Phone: 1-866-261-8400  
Toll Free Fax: 1-866-243-9959  
sales\_usa@habonim.com

**Habonim EUROPE**

Tel: +34 640 384 759  
sales\_eu@habonim.com  
sales\_international@habonim.com

**Habonim AUSTRALIA**

Tel: +61 400 001 988  
sales\_au@habonimau.com

**Habonim CHINA**

Tel: + 86 21 64453190 \*146  
sales\_china@habonim.com

**Habonim ISRAEL**

Tel: +972-4-6914911  
Fax: +972-4-6914935  
sales\_international@habonim.com

**Habonim UK**

Tel: +44-1633-484554  
Fax: +44-1633-482252  
sales\_uk@habonim.com

**Habonim SINGAPORE**

Tel: +65 6296 7828  
Fax: +65 6299 3184  
sales\_Singapore@habonim.com



www.habonim.com



Product Line Cat.

