

INDUSTRIAL VALVES



PRODUCT CATALOGUE





PERFORMING IN DEMANDING APPLICATIONS

Ball Valves & Actuators for the most demanding, challenging and hazardous applications is our passion and profession for the last 70 years. We believe in designing, manufacturing and supplying control and shutoff components and solutions that improves the overall safety, integrity and sustainability of the systems they are installed in.

Designed, manufactured and tested according to the highest standards, our products allow us to partner within systems that flows and control varied gases and liquids in divers markets especially where extreme temperatures and pressures are involved, hazardous materials are used and system performances are critical.

We are leading in cryogenic ball valve-based control solutions, emergency shutoff ,High Pressure and Severe Service and specially designed solutions. Believing that supplying and developing the most effective, safe and reliable products for the global leaders in the Gas distribution Severe Service and BioTech markets continually challenges us to improve our capabilities and products. Best coping with our prestigious customers' most challenging requirements technically, operationally and commercially is the outcome and our contribution to the development of these high end markets.

Table of contents

About Habonim	6
Habonim Valves	11
Industrial Valves	37



HOW TO USE THIS CATALOGUE

This catalogue provides information in a hierarchical structure starting from Habonim company general information, product families, product lines, product series and to a single product data.

When using information of any level, the aggregate information of the levels above would apply and should be taken into consideration where applicable.

Online Version

A live and up-to-date electronic version of this catalog is available for online use and download on Habonim: www.habonim.com



In the case of discrepancies between the print and electronic versions, we recommend to use the latest version (the version date is printed on the back cover).

Proprietary Note

This catalog is the exclusive property of Habonim Industrial Valves and Actuators Ltd. Any unauthorized reproduction of this catalog, in whole or in part, shall be prosecuted.

Disclaimer

The products and datasheets in this catalog reflect current Habonim standard production specifications. Habonim Industrial Valves and Actuators Ltd. Reserves the right to modify products and materials, including modifications undertaken to comply with specific customer requests and technical specifications without further notice.

It is always the system designer and the end-user responsibility to verify all equipment use in their system is properly selected to ensure safety and integrity of their systems. Habonim offers only general information based on common market knowledge and standard market adaptations for its valves. For each system and use, the system designer and end-user must consider the particular operations conditions, media parameters and any other implication of their system for the proper selection of valves to be used on their solely responsibility.

PRODUCT FAMILIES

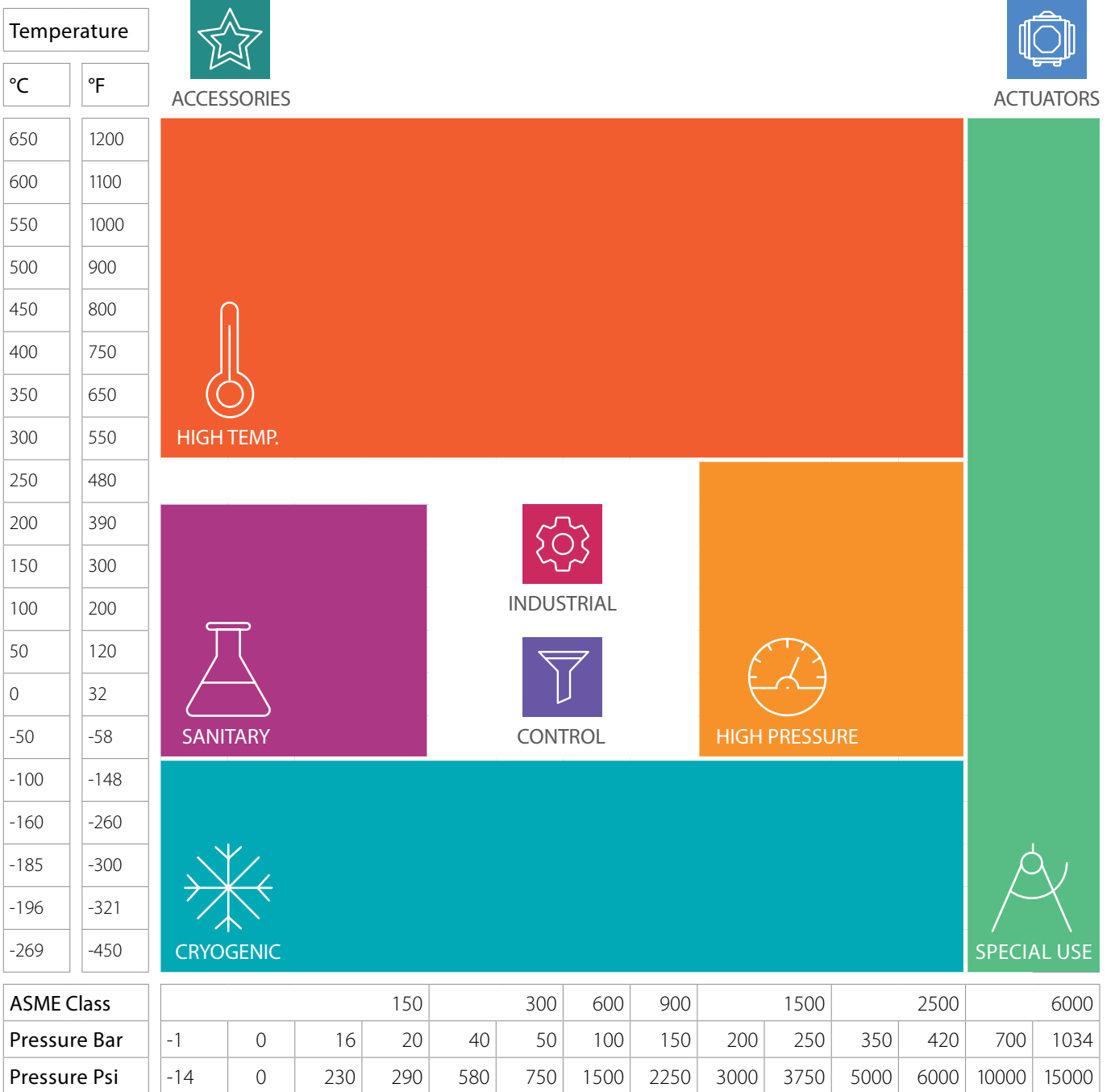

ABOUT HABONIM

Sustainability, Safety and Health

Habonim management and employees around the world are dedicated to promoting, in every aspect of their work, the following principles and guidelines:

Sustainability

Habonim management pledges to comply with the relevant laws, standards, and regulations to preserve the environment and promote sustainability at company premises and in our products.

Safety & Health

Habonim aspires to a safe and healthy work environment, aiming for zero work accidents and promoting our employee's wellbeing. Management and the entire workforce comply with the relevant laws and regulations necessary to achieve this goal.

Operations

Habonim operates a global infrastructure to best support customers and projects by supplying our catalog standard products, specially adjusted catalog products and custom-made products and sub-systems. Ball valves, actuators and control packages are our core deliveries.

Standard Delivery

With the goal of offering our high-end products as well as our general-use products with best availability, best quality, cost-effectiveness and with simple communication, handling and operation, we mark selected items designated as **Standard Offer** in most of our product lines with the Green "Standard Delivery" mark in order to provide best availability and supply readiness.





Materials

Habonim uses and stocks metallic, polymeric and other materials used in our products, all sourced from well-recognized manufacturers with the required testing, certifications and documentation.

Heat numbers and materials certificates are managed throughout the manufacturing and assembling process to enable full backtracking for our product components.

Available Certifications, some supply as standard and some per request:

- Materials certificates per EN10204 type 2.2/3.1/3.2
- FDA / USP Class VI compliant for polymers, elastomers, and lubricants where applicable
- CE1935:2004 compliant for polymers, elastomers, and lubricants where applicable

Tagging, Traceability

Each product is tagged for traceability. For product identification, a stainless steel nameplate is placed on the product body.

Traceability of assembly and testing procedures, heat codes, and foundry identification as per B16.34 stipulations where applicable.



ABOUT HABONIM

Cleaning, Assembling and Packing

Habonim manages different levels of cleaning, assembling and packing lines to meet different levels of end product and use requirements:

Commercial Service

Excessive hydrocarbon films, water, rust or mill scale, shop dirt, filings, chips or loose weld spatter is removed from the valve parts.

- Accessible surfaces are inspected for cleanliness by the naked eye under bright white light.
- Inaccessible surfaces are inspected and cleaned indirectly by wiping.
- A sticker on the package indicates the cleaning grade of the product.

Oxygen

A meticulous cleaning and assembly procedure eliminate the ignition hazards that can be caused by the presence of hydrocarbon oil, grease, and metal chips.

Our process of cleaning, assembling and packing refers to international standards in partial or in full:

- ASTM A380 • CGA G 4.1 • EN 12300

Habonim uses an environment friendly, alkaline-based degreasing process with controlled parameters. Valves are assembled in an oil-free restricted area by personnel who are specially equipped and trained to perform this task. The assembling area, work surfaces, equipment and tools are specially maintained to ensure cleanliness requirements are met.

- Valves are capped ends and plastic bagged
- A sticker on the plastic bag indicating "oxygen use"





Quality

Habonim strives to deliver quality products that meet and exceed customer expectations, providing complete and total satisfaction and to operate, instruct and train employees globally in light of standards such as:

- ISO 9001:2015
- CE PED 2014/68/EU (Module H)
- ATEX 2014/34/EU
- API SPEC Q1: 2013
- TPED 2010/35/EU and TPE - CDG 2009 – for specific product lines
- IEC 61508-2:2010 (SIL 2 / 3) – for specific product lines
- SIL IEC 61508-1,2, 2010/35/ EU – for specific product lines

Habonim's management diligently monitors goals and objectives and continually enhances processes and products as well as the safety and environmental practices in light of the above.

Testing and Laboratories

Habonim operates a wide range of testing laboratories and equipment for ongoing and R&D needs and certifies products for cryogenic, high pressure, aggressive or clean, industrial use and more.

Habonim carries out external and internal testing and certification of products per customers' requests and market trends on a regular basis and offer a wide range of certified products for diverse certification bodies as but not limited to:

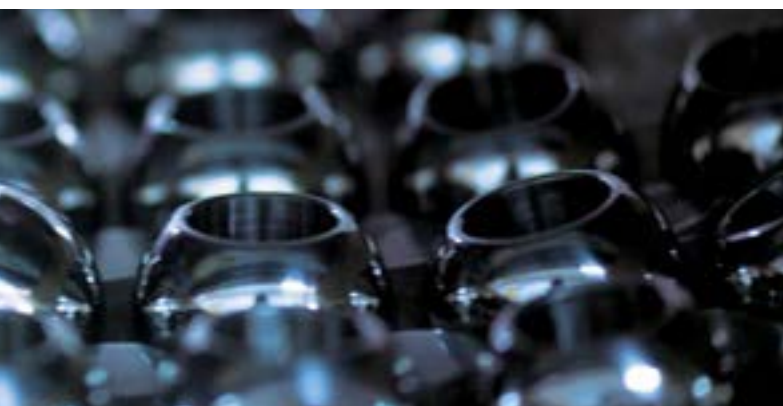

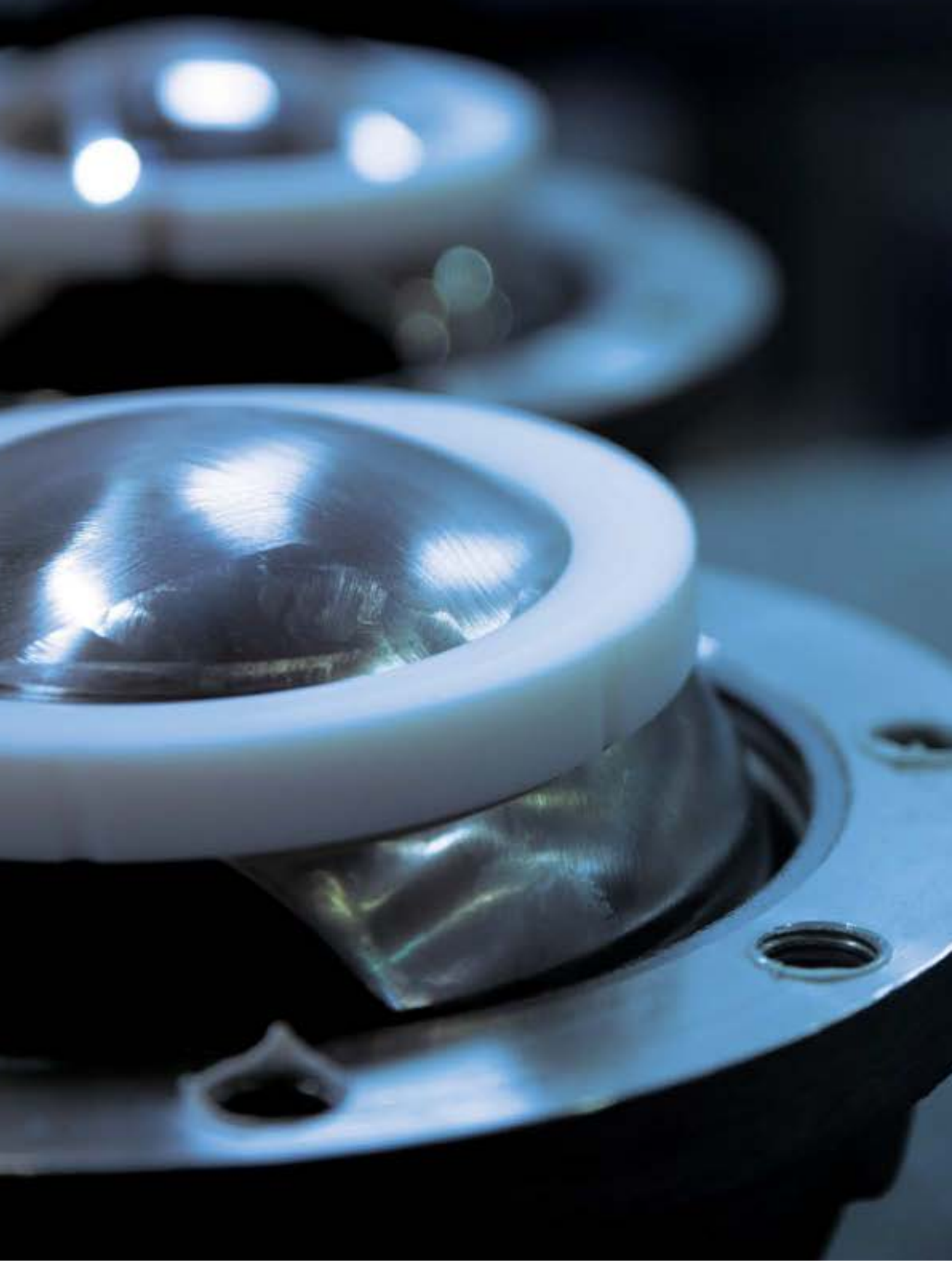



VALVES

Habonim Ball Valves	12
Valve Features	22
Industrial Valves	37

HABONIM BALL VALVES

General

Habonim develops, designs, manufactures, tests, supplies and service ball valves for the global market and is globally leading in some segments of ball valve usage. With high-end products, uncompromised quality, serviceability and innovation to create solutions for the most demanding applications Habonim has gained a long track record of proven success. Habonim's ball valve product line supports extreme cold to extreme heat systems, industrial use up to very high pressures, and meets the specific needs and regulations of a wide range of industries.



Habonim ball valve product lines are subject to the company's regulation, methodologies and certification – for more information, see Habonim introduction chapter.

Design and Engineering

Habonim designs its valves with accordance to international standards and guidelines in full, partial or with reference to. For some an external certification is available:

- API 6D (number 6D-1278)
- ASME VIII Div I
- API608
- ASME B16.34
- ISO 14313
- ISO 17292
- ASME BPE (48SER)
- ISO 15848-1, API641
- Fire safe design per API 607, ISO 10497, API6FA
- Antistatic design per ISO 17292

For relevant valves, Habonim complies or use as guidelines market leading standards such as, but not limited to:

- NACE MR-0175
- NDT/DT (according to ASME B16.34)
- MSS SP-55
- Polymers per TSE/BSE, BAM, FDA, USP, CE1935:2004





Testing

Habonim refers to the following international standards for valve testing:

- API 598
- ISO 15848-2
- API6D
- EN 12266-1/2
- ISO 5208

Strength/Valve shell leak test:

- Tested per quality system procedures
- By usage of compressed air, nitrogen or water

In-Line Leak Test:

- 100% of valves are tested
- By compressed air, nitrogen or helium
- At 5-7 bar pressure
- Pass criteria:
 - Rate A result (bubble tight shutoff) for soft seated valves

Functional Test:

- 100% of valves are tested
- Torque is tested to design limits

Packing

Habonim valves are delivered as a standard as:

- Valve in open position
- Actuated valves are delivered in fail-safe position
- Ends are capped
- A firm, clean package packed by soft, clean, shock-absorbing material for transportation protection.



HABONIM BALL VALVES



Registered EU Design
015025978-0001

As a standard, most of HABONIM valves are equipped with the Total HermetiX integrity package comprised of three main elements and a superior inline sealing mechanisms in some of them:

Zero fugitive-emission no maintenance stem sealing

- Patented HermetiX® stem sealing design with zero fugitive emission sealing capability.
- Tested or certified according to ISO 15848-1 and API641 standards.
- Up to 500,000 cycles of operation.
- Field proven for millions of cycles continuous operation.

Double body sealing

- Body-to-ends & body-to-bonnet double sealing for superior sealing.
- Selection of sealing materials for diverse applications.
- Fugitive emission prevention.

Fire-safe

- According to API 607 & ISO 10497 - where applicable.
- Type-tested and certified by leading certification bodies for marine service – for some valve series.
- Clean fire-safe construction guarantees no graphite contamination of the media flow.

Superior In-line sealing

A variety of implemented mechanisms provide extended in-line sealing capabilities such as:

- Bidirectional sealing
- High pressure full Δp sealing
- High & low pressure sealing
- Others

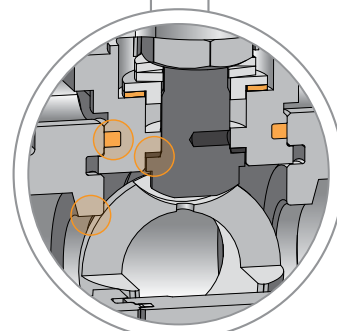
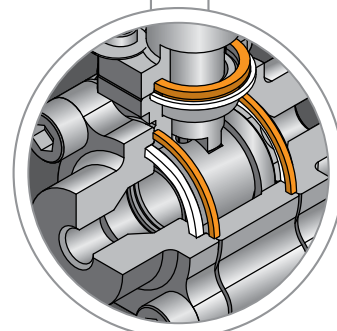
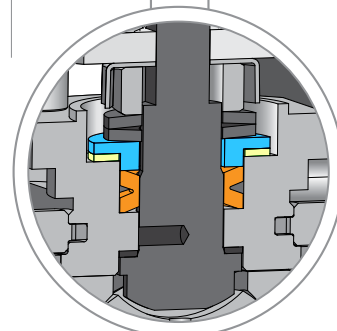



Quarter Turn Valves - Introduction

Quarter-Turn Ball Valves Design Styles

HABONIM offers ball valves in a variety of design styles and technologies that is most effectively supports a wide range of applications and use cases. We offer Floating ball style valves and Trunnion-mounted ball style valves with several construction methods.

Floating Ball Valves Design

The floating ball valve is the legacy style for ball valves, the most used and best fit for many industrial applications. The design places the valve ball between seats that holds it in place but without a firm connection to the valve body, hence, it "floats" inside the valve. Assuring a tight seal between the seats and the ball as well as the between the seats and the valve body guaranties the valve in-line sealing by a simple structure with minimal parts. As a rule of thumb, a floating ball valve should be considered as first choice wherever applicable.



Trunnion-Mounted Ball Valves

In a trunnion-mounted valve, the ball rotates only around its vertical axis while being mechanically anchored to the top and bottom of the valve body. This construction balances the torques of the rotating ball and keeps it in a lower range than with similar sized floating ball valves by tolerating the heavy loads applied to the valve trim as a result of large sizes, high pressures and dynamic temperature cycles. The seats are compressed against the ball sphere by the force of the springs and by the line pressure, providing "double block" or "double isolation" capability to the valve. Trunnion-mounted ball valves are often used for larger sizes, higher pressure ratings and dynamic temperatures.

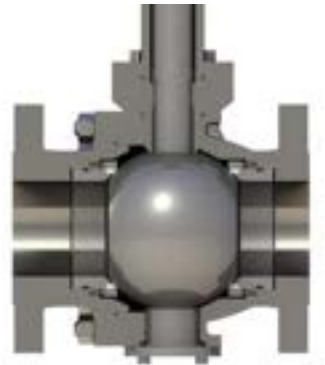

HABONIM BALL VALVES

Habonim Floating Ball Valve Designs

One-piece Design

The standard-port, one-piece, solid-cast body and flange design ensures minimum leak paths. The valve complies with ASME B16.5 for flange dimension and ASME B16.10 for Face-to-Face dimensions. The body includes an ISO 5211 integral mounting pad for easy automation. To facilitate easy assembly and maintenance, the valve is designed with one flange with a side entry that allows all inner parts to be positioned easily, and with a threaded plug that sets all parts under a precise preload with high repeatability. The result is optimum operating torque and bubble tight shut-off. It is possible to modify the ASME-standard flange connections by drilling the flanges to the EN1092 PN16 and PN40 standard. It is also possible to change one flange to a weld-end connection. A thermal jacket (steam jacket) over a one-piece design is the most efficient solution in applications where heating up the valve's outer surface (and the media inside) is mandatory to maintain media flow.

31 series | Vacuum 10^{-6} Tor; ASME B16.34 class 150 | Size ½"-8" (DN15-DN200)

32 series | Vacuum 10^{-6} Tor; ASME B16.34 class 300 | Size ½"-8" (DN15-DN200)

Two-piece Design

This unique full-port two-piece solid-cast body and flanged end design supports high flow capacity. The Habonim two-piece design is available in ASME B16.10 for Face-to-Face dimensions and ASME B16.5 class 150 and ASME class 300 flange dimensions and also in EN 1092 PN16 and PN40. The body includes an ISO 5211 integral mounting pad for easy automation. The valve is designed as a split construction which facilitates easy assembly and maintenance with standard tools. Tightening the end connector to the valve body via the body bolts preloads the complete ball-seat set, ensuring low operating valve torque, repeatability, and bubble tight shut off.

73 series | Vacuum 10^{-6} Tor; ASME B16.34 class 150 | Size ½"-8" (DN15-DN200)

74 series | Vacuum 10^{-6} Tor; ASME B16.34 class 300 | Size ½"-8" (DN15-DN200)

77 series | Vacuum 10^{-6} Tor; EN 1092 flanged PN16 | Size 3"-6" (DN80-DN150)

78 series | Vacuum 10^{-6} Tor; EN 1092 flanged PN40 | Size ½"-2½" (DN15-DN65)



Three-piece Design

The forged, cast, or rolled bar 3-piece design is comprised of a body (center section) and a variety of end connectors (thread, weld, flange) to facilitate a wide range of construction configurations. The swing-out design of the center section allows the end connector to remain a fixed part of the pipe work while the valve itself can be maintained by swinging out the center section only.

- 26 series** | Full port, solid cast | Vacuum 10^{-6} Tor
| In full compliance with ASME B16.34 class 600 | Size 2"-8" (DN50-DN200)
- 27 series** | Standard and full port, forged or rolled bar | Vacuum 10^{-6} Tor
| ASME B16.34 class 2500 (wall thickness) | Size ¼"-2" (DN8-DN50)
| ASME B16.34 class 1500 (wall thickness) | Size 2½"-8" (DN65-DN200)
| Hybrid seats technology as an option
- 28 series** | Standard & full port, forged or rolled bar, robust design, with Hybrid seats technology | Vacuum 10^{-6} Tor
| ASME B16.34 class 2500 (wall thickness) | Size ¼"-8" (DN8-DN200)
- 47 series** | Standard or full port design, forged, cast or rolled bar | Vacuum 10^{-6} Tor
| ASME B16.34 class 900 (wall thickness) | Size ¼"-2" (DN8-DN50)
| ASME B16.34 class 600 (wall thickness) | Size 2½" (DN65)
| ASME B16.34 class 400 (wall thickness) | Size 3"-6" (DN80-DN150)
- 48 series** | ASME BPE Floating Ball 3 Piece | Tube-size design, forged, cast or rolled bar
| Vacuum 10^{-6} Tor
| ASME B16.34 class 300 | Size ½"-1½" (DN15- DN40) | ASME B16.34 class 300
| Size 2"-6" (DN50- DN150)



Three-piece Threaded-Body Design

The forged, cast, or rolled bar 3-piece threaded-body design is comprised of a body (center section) and a variety of end connectors (thread, Coned & Threaded) to facilitate a wide range of construction configurations. The no-bolts design of the valve is suitable for high and very-high pressures.

- 24 series** | Standard and full port, Floating ball design, forged or rolled bar
| Vacuum 10^{-6} Tor | In full compliance with ASME B16.34 class 2,500
| Size ¼"-1½" (DN8-DN40)
- 25 series** | Forged or rolled bar | Floating ball design | Vacuum 10^{-6} Tor
| In full compliance with ASME B16.34 for 550 bar (8,000psi)
| Size ¼"-1½" (DN8-DN40)
- 29 series** | Forged or rolled bar | Floating ball design | Vacuum 10^{-6} Tor
| In full compliance with ASME B16.34 for 1,034bar (15,000psi)
| Size ¼"-1½" (DN8-DN40)



HABONIM BALL VALVES

Habonim Floating Ball Valve Designs

Multiport valves

Multiport valves are primarily used to simplify pipe and valve systems by replacing multiple two-way valves with a single multiport valve. They minimize dead legs, optimize drainability, simplify system validation and have a reduced envelope profile for easier installation. Multiport valves allow piping and machine engineers to design a simpler system that saves space and has fewer flow elements and leak paths. One multiport valve can replace multiple two-way valves and automation devices, and provides safe and easy changeover and flow shutoff, all within a confined space. Reducing the quantity of piping and fittings also means faster and more cost-effective construction. Available in a variety of flow patterns and directions and in both automatic and manual configurations, the design possibilities offered by the multiport valve are virtually unlimited.

61 series | Multiport with three horizontal ports
| Standard or full port design, forged or cast
| Vacuum 10^{-6} Tor
| ASME B16.34 class 600 (wall thickness) | Size ¼"-1½" (DN8-DN40)
| ASME B16.34 class 300 | Size 2"-4" (DN50-DN100)

62 series | Multiport with four horizontal ports
| Standard or full port design, forged or cast
| Vacuum 10^{-6} Tor
| ASME B16.34 class 600 (wall thickness) | Size ¼"-1½" (DN8-DN40)
| ASME B16.34 class 300 | Size 2"-4" (DN50-DN100)



Diverter valves

Diverter valves are primarily used to split or combine process flows, or to switch medium among different pieces of process equipment such as pumps, filters, or whole pipelines. Diverter valves provide reliable high flow rates in the most severe operating conditions, including vacuum conditions. They can also handle highly viscous media without the need for constant back-flushing. The diverter valves are available with different ball designs to accommodate a wide range of flow patterns. These flexible flow combinations reduce the number of valves in a system, thereby saving costs and facilitating easier control. Because all of the diverter valves have the same body Face-to-Face dimensions, they can be used with all standard end connections.

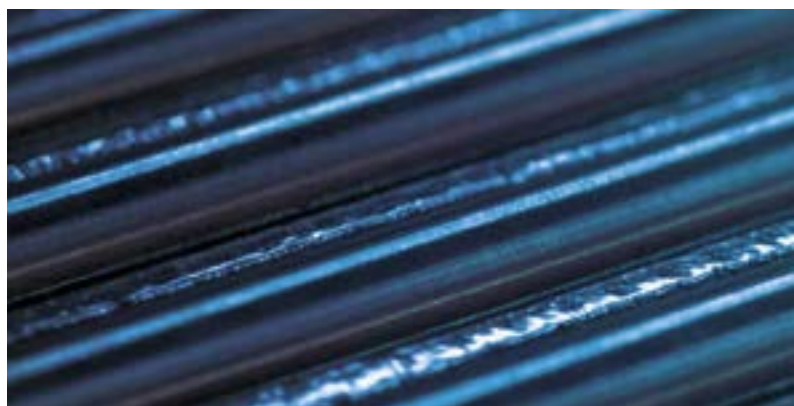



- D31 series** | Bottom entry diverter
| Standard port design, cast | Vacuum 10^{-6} Tor
| ASME B16.34 class 150 (wall thickness) | Size ½"-8" (DN15-DN200)
- S31 series** | Side entry diverter
| Standard port design, cast | Vacuum 10^{-6} Tor
| ASME B16.34 class 150 (wall thickness) | Size ½"-8" (DN15-DN200)
- D32 series** | Bottom entry diverter
| Standard port design, cast | Vacuum 10^{-6} Tor
| ASME B16.34 class 300 (wall thickness) | Size ½"-8" (DN15-DN200)
- S32 series** | Side entry diverter
| Standard port design, cast | Vacuum 10^{-6} Tor
| ASME B16.34 class 300 (wall thickness) | Size ½"-8" (DN15-DN200)
- D47 series** | Bottom entry diverter
| Standard or full port design, forged or cast | Vacuum 10^{-6} Tor
| ASME B16.34 class 600 (wall thickness) | Size ¼"-2½" (DN8-DN65)
| ASME B16.34 class 300 (wall thickness) | Size 3"-6" (DN80-DN150)
- S47 series** | Side entry diverter
| Standard or full port design, forged or cast | Vacuum 10^{-6} Tor
| ASME B16.34 class 600 (wall thickness) | Size ½"-2½" (DN15-DN65)
| ASME B16.34 class 300 (wall thickness) | Size 3"-6" (DN80-DN150)
- D61 series** | Multiport with three horizontal ports
| Additional bottom port available
| Standard or full port design, forged or cast
| Vacuum 10^{-6} Tor
| ASME B16.34 class 600 (wall thickness) | Size -1" (DN8-DN40)
| ASME B16.34 class 300 | Size 2"-4" (DN50-DN100)
- D62 series** | Multiport with four horizontal ports
| Additional bottom port available
| Standard or full port design, forged or cast
| Vacuum 10^{-6} Tor
| ASME B16.34 class 600 (wall thickness) | Size -1" (DN8-DN40)
| ASME B16.34 class 300 | Size 2"-4" (DN50-DN100)

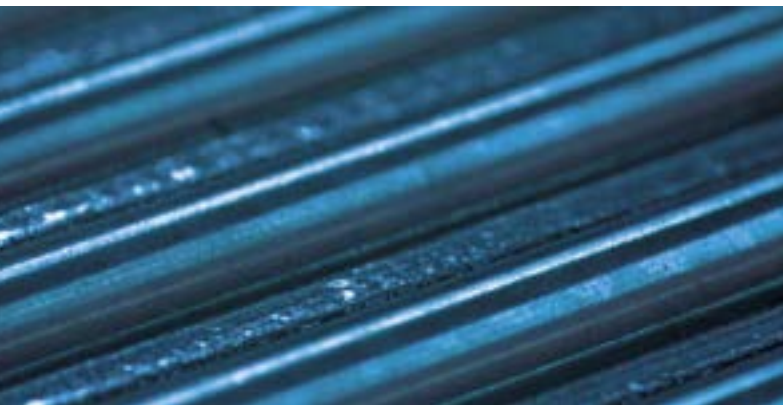

HABONIM BALL VALVES

Habonim Trunnion-Mounted Ball Valve Designs

Features:

- Specially designed to endure the harsh conditions of the oil & gas, petrochemical and other demanding applications
- Underground, above ground, offshore and onshore installation
- Full differential pressure (Δp) per the valve pressure rating
- Manually applies a maximum operating force of 360N (80 lbf)
- Double block & bleed single valve capability
- Seats preloaded by helical springs
- Antistatic grounding between ball, stem & body as standard
- Bi-directional flow
- Double Piston Effect (DPE) and Single Piston Effect (SPE) designs are both available
- Optional additions for 8" valve size and above:
 - Injection fittings for emergency stem or seat sealant & lubrication maintenance
 - Equipped with lifting lugs
 - Manually operated via gearbox
- Buttweld end valves may be supplied with extended spool pieces (PUPS) to avoid any risk of seat and seal damage during welding and post weld heat treatment operations

External finishing:

- Austenitic stainless steel valves are delivered in their natural finish
- Carbon steel valves are sandblasted and externally coated with paint
- Other painting systems are available upon request

One-Piece Design

- 52 series** | Cryogenic Top Entry Trunnion Mounted
| Size 1½"-6" (DN40-DN150) | Class 300





Two-Piece Design

The 2-piece cast trunnion-mounted ball valve designs are cost effectively support pressure ratings up to ASME Class 600, serving as the first choice where applicable with ANSI flange ends.

- 81 series** | Full Port | Vacuum 10^{-6} Tor
| ASME B16.34 class 150 (wall thickness) | Size 2"-16" (DN50-DN400)
- 82 series** | Full Port | Vacuum 10^{-6} Tor
| ASME B16.34 class 300 (wall thickness) | Size 2"-16" (DN50-DN400)
- 83 series** | Full Port | Vacuum 10^{-6} Tor
| ASME B16.34 class 600 (wall thickness) | Size 2"-16" (DN50-DN400)

Three-Piece Design

The 3-piece forged body and end design is a robust heavy-duty design for pressure ratings up to ASME Class 2500 With ANSI flange, DIN flange or weald ends.

- 91 series** | Full & Standard Port | Vacuum 10^{-6} Tor
| ASME B16.34 class 150 (wall thickness) | Size 2"-16" (DN50-DN400)
- 92 series** | Full & Standard Port | Vacuum 10^{-6} Tor
| ASME B16.34 class 300 (wall thickness) | Size 2"-16" (DN50-DN400)
- 93 series** | Full & Standard Port | Vacuum 10^{-6} Tor
| ASME B16.34 class 600 (wall thickness) | Size 2"-16" (DN50-DN400)
- 94 series** | Full & Standard Port | Vacuum 10^{-6} Tor
| ASME B16.34 class 900 (wall thickness) | Size 2"-16" (DN50-DN400)
- 95 series** | Full & Standard Port | Vacuum 10^{-6} Tor
| ASME B16.34 class 1500 (wall thickness) | Size 2"-12" (DN50-DN300)
- 96 series** | Full & Standard Port | Vacuum 10^{-6} Tor
| ASME B16.34 class 2500 (wall thickness) | Size 2"-12" (DN50-DN300)

Three-Piece Threaded Body Design

- 99 series** | forged or rollrd bar | Trunnion ball design | Vacuum 10^{-6} Tor
| In full compliance with ASME B16.34 for 1,034 bar (15,000psi)
| Size ¼"-1" (DN8-DN25)



VALVE FEATURES

Fire Safe Design

Valves to be used in explosive or fire-hazard areas need to be (according to some standards and regulations) be designed to prevent in-line leaks for at least 30 minutes when exposed to flames and/or temperatures between 900 - 1000°C. In addition, after cooling down, a fire-safe valve has to be able to be cycled once and seal at an acceptable level of in-line leakage.

Habonim fire-safe valves include body seals fabricated from graphite, which is well-known as a fire-retardant material. In the event of fire, the valve's soft seats melt and the ball is pressed against a metallic fire lip on the downstream end connector thus preventing in-line leakage. The fire also burns off the stem's thrust seal, causing the stem, which has a machined chamfer at its root, to be pushed up and form a metal-to-metal seal with the valve body and prevent leakage. For stem sealing Habonim is using the patented HermetiX seal, a unique polymer-based graphite-free stem seal that, even after its polymer materials have melted, allows the stem to stay aligned and fully operable after cool-down. During normal operation, our polymer-based stem seal allows 500,000 operation cycles without maintenance, making it remarkably more durable than porous graphite seals, which have to undergo maintenance every 5,000 cycles without refurbishment. This design has been tested and certified to API 607 and ISO 10497 standards.

Tongue & Groove Body Seal Design

A 'tongue' machined on one side of the valve body and a matching 'groove' machined on the opposite side provides a perfect interlock system that precisely aligns the body and ends along the valve's center axis, thus increasing accuracy and repeatability during valve assembly and maintenance. The tongue & groove design is used most of our fire valves so that the expanded body seal is fully encapsulated and compressed in the event of a fire. The tongue & groove design forces fluid emissions to flow in a labyrinth pattern, thus ensuring zero leakage into the atmosphere.

Body Bolts

Instead of long through-way bolts and nuts, all of our 3-piece fire-safe valves use double the number of one-size-up short bolts threaded into the body. In the event of fire these bolts minimize thermal expansion and prevent external leakage.

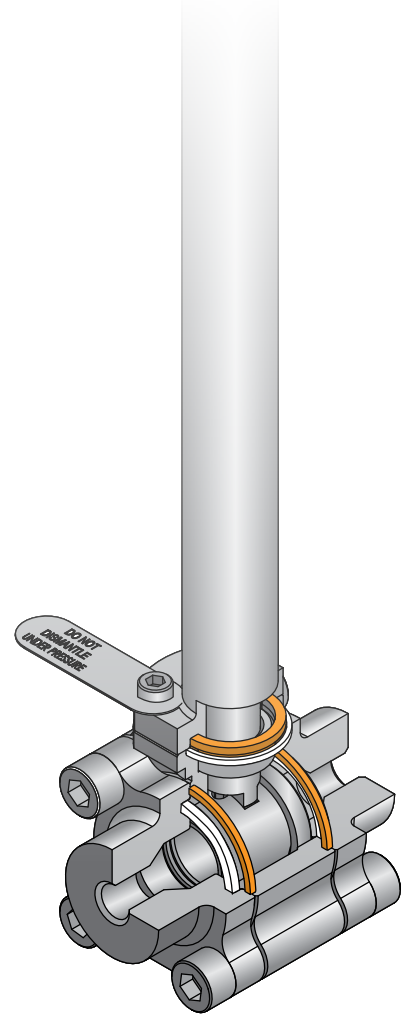



Ball Configurations

Our mirror-polished solid balls ensure tight shutoff and long service life. All balls come with specially rounded leading edges to eliminate excessive seat wear during rotation. Our balls technology can supports change to variety of metals (some are available only upon request) such as Stainless Steel 316 (CF8M), Alloy-C276, Alloy-C22, Monel 400, 254SMO, Duplex, Super Duplex, Inconel 625, Titanium and more. Ball materials other than Stainless Steel 316 (CF8M), are marked for clear identification.

There are different styles related to the ball port itself:

- Standard port ball (also known as reduced port) - The flow through the ball is one size smaller than the pipe's size resulting in a flow area smaller than the pipe's area. The reduced flow area increases the flow velocity (assuming a constant flow discharge) and the head-loss over the valve.
- Full port ball - Has an over-sized ball so that the ball's port is the same as the pipe's inner diameter, thus reducing friction loss. Flow is unrestricted but the valve is larger so full-port balls are typically used where free flow is particularly important such as in pipelines that require pigging.
- Tube size ball (also known as true port) has a port which is identical to the tube's inside diameter. This configuration is used mainly in the pharmaceutical industry where dead legs and pockets of contamination are unacceptable.

Pressure Equalizing Hole

Balls typically have a hole in the stem slot to equalize the pressure over the ball sphere. The pressure inside the ball port and the pressure in the valve cavity are identical and hence no stress is applied to the ball sphere. The pressure equalizing hole is eliminated in the following cases:

- High surface finish requirements, mechanically polished or electro-polished
- Diverter valves
- Valves with cavity filler seats
- Double block and bleed valves
- Pharmaceutical or other applications with very high sanitary requirements



Minimum stress on the ball by adding a pressure equalizing hole



VALVE FEATURES

Ball Configurations

Cavity Pressure Relief

This safety feature is for valve applications where a trapped cavity must be avoided a 3 mm hole is included in the upstream ball sphere so that any pressure that builds up in the valve cavity will be released into the upstream pipeline. The use of a cavity pressure relief hole feature is mandatory when using ammonia, chlorine or any other liquid media that is at risk of transforming into a gas and thus elevating the pressure within the valve cavity in an uncontrolled manner. A valve which includes the 'P250' code will always be unidirectional, and will include an arrow flow plate attached to the valve body. Improper installation in the opposite direction will cause an in-line leak.



3 mm relief hole
face the upstream

'C' Ball

Habonim offers a two-way ball with its upstream sphere completely machined through the ball port and thus has a C shape. This feature is mainly used where media tends to crystalize on the upstream ball sphere such as, for example, molten sugar or baked ground coffee. When a standard valve is in the closed position and a solid layer has adhered to the ball's upstream sphere, subsequent valve operation will erode the upstream soft seat, loosen the pre-load of the ball seats set, and rapidly degrade the valve's functionality. With a 'C' ball media solidification is impossible as there is no surface area on which the media can accumulate. The upstream seat withstands the media unscratched; the pre-load of the ball seat set as well as the functionality of the valve remain intact for a longer period of time.



Upstream sphere completely
machined in a 'C' ball

Multiport and Diverter Ball

Multiport and diverter ball designs are used primarily to split or combine process flows or to switch medium between alternative pieces of process equipment. The diverter ball configuration can be either bottom entry or side entry. The diverter ball has the same sphere diameter as standard 2-way balls so the same soft parts can be used. Multiport balls have numerous flow configurations, which are described in detail in the Multiport chapter of this catalog. The multiport ball has a larger sphere diameter than a diverter ball, allowing a firm grip of four seats vs. two seats in the diverter configuration.



Diverter ball with isometric
T port construction

V-Ball

The V ball is used in control valve solution for less demanding applications, such as clear liquid at a maximum pressure drop of 6 bar (87 psi), or clean gas at a maximum pressure drop of 10 bar (145 psi), and maximum temperatures of 120-°C (248-°F) for both. The V ball design is comprised of a floating characterized ball, mounted between two seats, which maintain a trim preload and bubble-tight shut-off and low torque demand. V-Balls come in a variety of 'V' and 'slot' shapes, and can be custom designed to meet any control requirement. The V-Ball is available in a wide range of high-alloy materials and coatings for highly corrosive applications.



Characterized ball for flow
control applications



Downstream Pressure Relief Ball

Habonim ball downstream pressure relief is designed with a diagonal hole in the downstream sphere toward the bottom of the ball. In the open position the flow runs smoothly through the valve. When the valve is closed the downstream pressure is vented through the diagonal tunnel and out via a third port incorporated into the valve body so that the relieved pressure can be diverted safely to a secured area. This feature is mainly used for pressure gauges and instrumentation service. This design eliminates the need to install an additional downstream pressure vent valve.

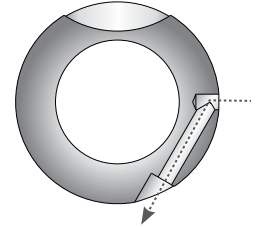

Special diagonal tunnel vents downstream pressure when the valve is closed.

CIP/SIP

Habonim 'CIP' ball code is mainly used in sanitary and biopharm applications. In clean applications the main ball valve problem is contamination caused by impurities trapped in the cavity between the ball's outer sphere and the valve body's inside diameter. To overcome this problem Habonim has designed a special ball that allows the stream to clean the valve cavity thoroughly during the CIP/SIP process, with the valve in the full open position. The bottom line: Bidirectional and streamlined flow with a high Cv, and self-cleaning of hidden cavities.

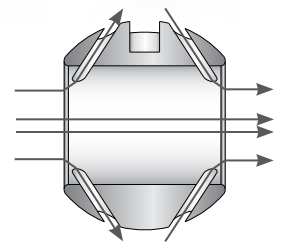

With the valve in the open position, special tunnels flush the valve cavity constantly



VALVE FEATURES

Seat Configurations

Standard Seat

A flexible, precision-machined seat that provides the highest seal capabilities (EN12567 Rate A) in high pressure and vacuum conditions. Its unique design reduces valve torque, facilitating a more compact, lower-weight automated package. The design also reduces wear, thus extending the life of the seat. The seat perimeter has pressure-equalizing slots to allow pressure to penetrate into the body cavity for better sealing and for avoiding upstream seat collapse into the valve cavity while turning the valve ball from the open to closed position under high differential pressure.



Standard seat

Self-Relieving-Seat (SRS)

The Self Relieving Seat (SRS) is used mainly in syltherm and dowtherm services in the chemical and biopharm industries. Both syltherm and dowtherm have a high thermal expansion coefficient and in trapped cavities (such as when the valve ball is in its closed position) even a moderate temperature increase will cause dramatic pressure build-up that can cause cessation of valve operation, seat swelling, and even valve shell failure. The SRS is designed to flex and allow the trapped pressure to escape into the pipeline, while shutting off as soon as the peak pressure is relieved. The pressure relief is achieved by a special internal groove that is machined into the seat radii facing the ball. Additional radial grooves enable the pressure to bypass the ball and access the internal groove. The seat sealing surface is in the central internal section and provides tight shutoff. The outer section of the seat above the internal groove gives the support needed to the ball when higher line pressure pushes the ball toward the downstream seat, thus preventing "crushing" of the seat. SRS seats can be used with a differential pressure up to ASME Class #300.



Self-Relieving-Seat (SRS)

Seat-seal

In some use cases valve must seal the pressure at the upstream side, which contradicts the traditional floating ball mode of operation (where sealing is typically done on the downstream seat only). Habonim's solid one-piece seat-seal design blocks the flow through the back of the seat, generating an upstream seal. Seat-seal can be used with differential pressure up to ASME Class300. For higher differential pressures use either a valve with hybrid seats, or a dual floating ball valve integrated into a one block or trunnion mounted valve.



Seat-seal

Hybrid Seat

When a soft seated floating ball valve is held even momentarily at mid position, the upstream seat is only partially supported by the ball and can be pushed towards the valve cavity by the force of the stream. This deformation is amplified with increased media density, high differential pressure and/or high velocity. Under these extreme conditions the deformation can: cause the ball to grip the unsupported area of the soft seat and jam the valve; slice the seat by the port edge of the ball; or trigger stem twisting (caused by excessive torque applied by the operator trying to close the valve). Habonim's line of Hybrid seats were developed especially to overcome the problems posed by high differential pressure applications. The combination of a metallic housing and polymer insert offers the stiffness of a metal seat with the bubble tight shutoff leakage rate and operating torque of a soft seat. Different hybrid seat designs were developed to meet the needs of different applications, and are designated by the metallic housing design.



Hybrid seat



Seat Configurations

Cavity filler seat

The cavity filler seat design minimizes crevices and gaps between the ball and the valve body, thus reducing the risk of trapped contaminants. Because the valve body is specially machined with a larger bore diameter to fit the special cavity filler seat dimensions, they cannot be retrofit into a standard valve body. The cavity filler seat is a one piece seat-seal design and is therefore suitable for use with the Habonim 3-piece product line.

Note: A valve with a cavity filler seat cannot be used in fire-safe service.

Metal seat

Habonim metal seats are used for extreme service applications where high temperature, abrasion and/or corrosion restrict the use of soft seats. The metal seats are mated lapped with the ball for enhanced engagement and sealing. A variety of surface treatments and coatings can be applied to the seat's outer surface to withstand corrosion, galling and other forms of wear.

V-port seat

Superior control performance and accuracy is designed into the geometry of the downstream V-port. The precision wire cut 'V' shape of a metal seat, enables equal percentage flow characteristics, while S-port design ('Slot') provides linear flow characteristics. V-Port valve assembly, comprised of a ball and wire cut metal seat, lapped together into a single seamless component. V-port design provides the high rangeability and precision throttling required for clean or dirty liquids and gases, as well as fibrous suspension applications. The streamlined flow passage allows for high recovery, maximum efficiency and excellent erosion resistance.



Cavity filler seat



Metal seat



V-port seat



VALVE FEATURES

Stem Design

A crucial component in a quarter-turn ball valve is the stem, which transfers the torque from the operator to rotate the ball and control its movement. The stem geometry and surface finish is crucial to minimize stem leak and maximize ease of operation. The stem is a dynamic element and, in most cases, is the only element that protrudes from the pressure vessel and is thus subject to safety issues as well. Habonim's robust stem design complies with ASME B16.34 and API 6D and can endure at least twice the valve's nominal torque. To solve a major safety issue, the stem is designed to be "blowout-proof". Because it is inserted into the valve body from within, the stem will not release under pressure. All Habonim stems are, by default, fire-safe design. A special chamfer is machined at the root of the stem so that, in the event of fire, the stem is pushed upwards and seals against the valve body - metal to metal engagement. Various stem materials are available, from austenitic stainless steel to nickel alloys, to titanium for light and moderate torque requirements, and for high cycle applications or high torque demands. The stem top planes for valve sizes ½" (DN15) up to 2½" (DN65) are typically a Double-D shape, while 3" (DN80) stems and above typically have a square shaft (although a Double-D stem can be provided upon request by adding the 'WR' suffix to the valve description).

Anti-Static Design

An anti-static device provides for electrical continuity between the body, ball and shaft of the valve and is used to discharge static electricity buildup on electrically isolated balls. According to the EN ISO 17292 standard, all valves with a size up to 2" (DN ≤ 50) require a stem/body contact, while larger valve sizes also require a ball/stem contact. The anti-static feature shall have electrical continuity across the discharge path with a resistance not exceeding 10 Ω from a power source not exceeding 12 VDC when type tested on a new, dry, as-built valve after pressure testing and cycling of the valve at least five times. The Habonim anti-static device, in which contact is made via a spring loaded stainless steel element, complies with EN ISO 17292 and is, in fact, built-in to all Habonim valve product lines, without exception.

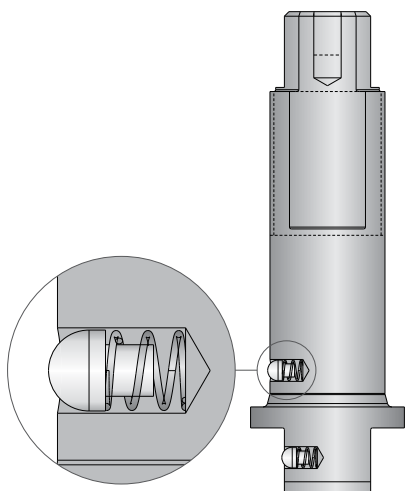

Anti-static design

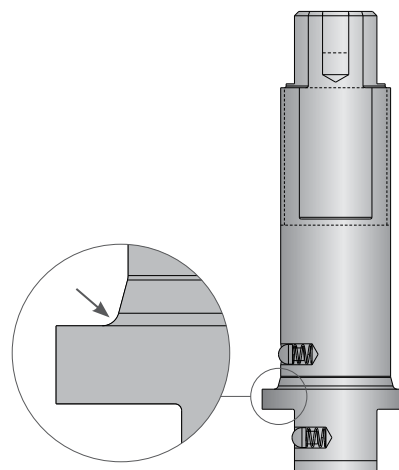

Stem design



Stem Seals

The valve trim - and the valve stem seal design in particular - determine the quality of a valve. The stem seal must perform two tasks: keep the media within the boundaries of the pressure vessel, and allow uninterrupted leak-free continuous open/closed quarter-turn rotation.

Unlike the valve body's static seal, the stem seal is subject to dynamic operation of the valve, as well as to side loads resulting from actuator misalignment or from the operator forcing the handle incorrectly. The valve trim typically comprises two Belleville springs assembled Face-to-Face, which preload the stem seal. This self-adjusting mechanism compensates for wear and pressure/temperature differentials - ensuring a leak-tight seal and extended service life. Habonim's trim design for heavy-duty service, such as high cycle applications, uses four or even six sets of Belleville springs so as to maintain preload over a longer operational cycle life. The Belleville springs are compressed by the stem nut, which is locked to prevent unintentional release during cycles.

Habonim's stem seal design, consisting of a live-loaded thrust bearing and anti-abrasion ring combined with a stem seal, significantly increases valve cycle life over conventional ball valves and extends the time between adjustments.



VALVE FEATURES

Stem Seals

Graphite-free fire safe HermetiX® stem seal

The patented HermetiX® stem seal is named for its distinctive "X"-shaped design. The flexible "X" shape creates a dynamic sealing arrangement so that, in the event of pressure buildup or side load, the HermetiX® adjusts dynamically to prevent fugitive emissions. The result is a superior stem seal design compared with the conventional flat stem seals currently available on the market.

The HermetiX® Fire-safe. This patented design includes a polymer based stem seal and a unique fire safe certified construction. The graphite-free stem seal, suitable for use in hazardous industries such as chemical, petrochemical, oil & gas, Food & Beverages is designed to operate for 500,000 cycles without refurbishment. The HermetiX® fire safe valve offers the ultimate solution - an exclusive graphite free stem seal that eliminates the risk of graphite disintegration after prolonged valve cycles, protecting both line materials and air quality. The HermetiX® fire safe valve meets the requirements of fire-safe API 607 / ISO 10497 standards, as well as the stringent ISO 15848-1 standard.

Features

- Prevents media contamination from graphite particles
- FDA, CE1935:2004 approved polymer or other materials is available upon request
- Fugitive emission certified to ISO 15848-1 and API 641
- Habonim patented design
- Designed to operate for 500,000 cycles without refurbishment
- Prevents media contamination from graphite particles
- Ensures uninterrupted production
- Increases site safety
- Anti-static as standard

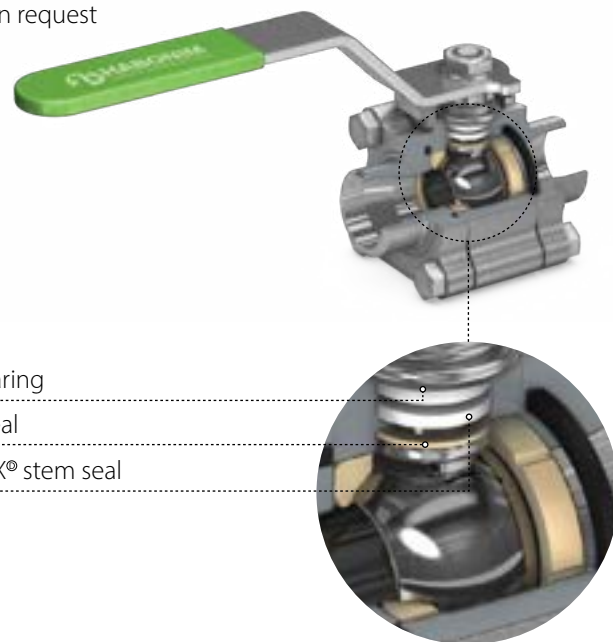
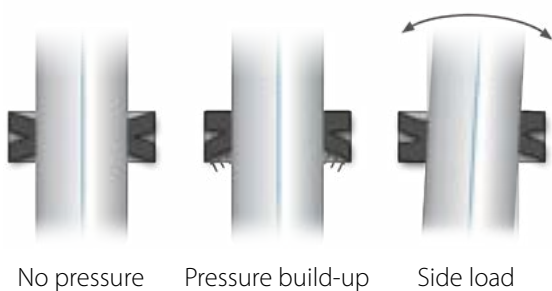



High Cycle (HC) Stem seal

High cycle service is defined by Habonim engineering as continuous operation for more than one hour at a frequency greater than 1 cycle / 180 seconds.

When designing a valve for high cycle service parameters, such as heat dissipation due to friction of metallic and plastic parts, resistance to fatigue stress, and mean time between maintenance activities must be taken into consideration.

For high cycle applications Habonim recommends the use of valve stems made of high tensile material. The stem will be polished for a high degree of surface roughness. The stem thrust seal will always be made from highly wear-resistant plastic material. A Viton O-ring is inserted into a customized follower. The complete trim assembly is preloaded by a double or even triple Belleville spring stack. All of these design features give the valve a particularly long service life.

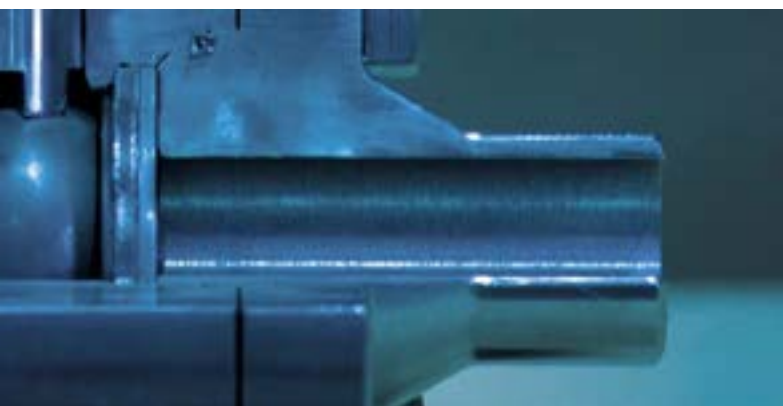
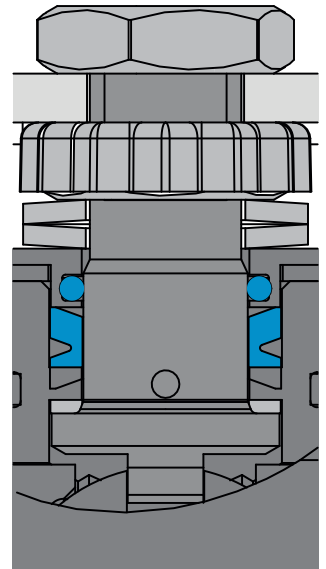

VALVE FEATURES

End Connections

Habonim offers a variety of end connections for its 3-piece valves, supporting the industry standard connections for piping in diverse applications and geographies.



TC/TCI/TCD

Tri-Clamp end - designed to ASME BPE (TC) standard, allows fast connection or removal of the valve from the line. Mainly used in the pharmaceutical and food & beverage industries.

BW

Buttweld end for various pipe schedule - designed to ASME B16.25, EN12627-4, BW code stands for buttweld schedule 40, for different pipe schedule BW should be followed by the relevant schedule number (5,10,80,160)



SW

Socket-weld end one piece solid cast designed to ASME B16.11 and EN 12760. Leaving a 1 mm gap (average) between the pipe end and the socket inner plan is a common welding practice to avoid internal stress due to thermal expansion during the welding process



XBW

Extended buttweld end for various pipe schedule - one piece solid cast - special design for in-line welding save labor cost and keep the integrity of the product factory tested.



XSW

Extended Socket-weld end one piece solid cast - special design for in-line welding save labor cost and keep the integrity of the product 'factory tested'



BWO / BWI / BWD

Buttweld end for various tube standards - designed to ASME BPE (BWO), ISO 1127 (BWI) and DIN 11850 (BWD). The length of this end doesn't allow the use of orbital welding.



ETO / ETI / ETD

Extended buttweld end for various tube standards - designed to ASME BPE (ETO), ISO 1127 (ETI) and DIN 11850 (ETD). One piece solid cast with sufficient length to allow the use of orbital welding. Habonim ETD end connections are designed in accordance to EN10357 – Series A.

Habonim ETI end connections are designed in accordance to EN10357 – Series C.

Dimensions of the end-connections tube ends are suitable to be welded on tubes that meet this standard.

For other tube sized ends please contact a Habonim representative.



Standard	Sizes	Wall thickness (mm)	End Connection (19-22)	End Connection Length
ISO 1127	3/8"-3/4"	1.6	BWI1.6	Short
			ETI1.6	Extended
	1"-2 1/2"	2.0	BWI2.0	Short
			ETI2.0	Extended
	Over 2 1/2"	2.3	BWI2.3	Short
			ETI2.3	Extended



CTM

Coned and Threaded type female connection to be used with Coned & Threaded medium-pressure tubing and connection components.

Female connection geometry and sizes per the Below.

Size	Dimensions - mm (inches)					
	A	B	C	D	F	H
02	9.9(25/64)	7/16-20	7.1(.28)	12.7(.28)	4.8(.19)	2.8(.109)
03	13.1(33/64)	9/16-18	9.6(.38)	9.6(.38)	7.9(.31)	5.2(.203)
06	19.1(3/4)	13/16-16	11.1(.44)	11.1(.44)	12.7(.50)	9.1(.359)
07	32.9(1.19/64)	3/4-14	12.7(.50)	12.7(.50)	16 (.63)	11.1(.438)
10	45.47(1.79)	1 3/8-12	20.6(.81)	20.6(.81)	22.4(.88)	14.3(.562)

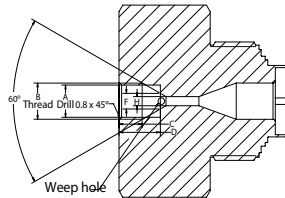

NPT / BSPT / DIN2999 / DIN3852

Female thread end designed to ASME B1.20.1 NPT EN 10226-1 BSPT/DIN2999/DIN3852 and more



MNPT / MBSPT

Male thread end designed to ASME B1.20.1 NPT EN 10226-1 BSPT/DIN2999/DIN3852 and more



LL / LM

Compression ends for metric (code LM followed by the tube OD in mm) or imperial (code LL) tube dimensions. mainly used in instrumentation services, with sizes up to 1" (DN25)



Grayloc®

Grayloc® compatible hub designed to fit an opposite hub for an easy low or high pressure connection Using a self-energized seal (Grayloc® is a registered trademark of Grayloc Products, L.L.C.)



Flanged			
150	ASME B16.5 #150 RF	PN16	EN1092 PN16 RF
300	ASME B16.5 #300 RF	PN40	EN1092 PN40 RF
600	ASME B16.5 #600 RF	PN63	EN1092 PN63 RF
900	ASME B16.5 #900 RF	PN100	EN1092 PN100 RF
		PN160	EN1092 PN160 RF



150/300/600/900 | PN16/40/63/100/160

Raised Face flange ends designed to ASME B16.5 or EN1092 for a variety of pressure classes.

Valve Face To Face sizes are per Habonim catalog data only.

VALVE FEATURES

Handles

A valve handle is the interface between the operator's hand and the valve trim. Habonim's handles are designed for safe operation, with a firm and comfortable grip. To facilitate ease of operation, the handle length ensures that the maximum force required at the handle-end to apply the breakaway torque will never exceed 360 N (80 lbf). The handles are manufactured in a variety of technologies: casting, forging, punching, and laser cut and welding. The standard materials are zinc plated carbon steel and stainless steel. Habonim's range of handle designs addresses the diverse needs of multiple applications.

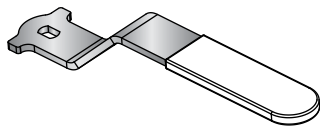

The 'SHARK' handle

Habonim's standard handle for valves with an ISO 5211 top pad.

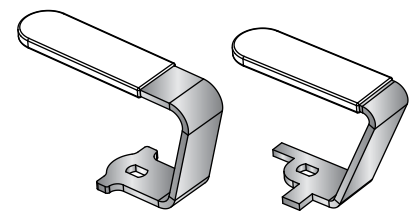

The 'SCORPION' handle

Habonim's special handle for confined spaces. There are two types to accommodate valves with or without an ISO 5211 top pad. To specify a valve with the SCORPION handle add the '-SCRIP' suffix to the valve code.

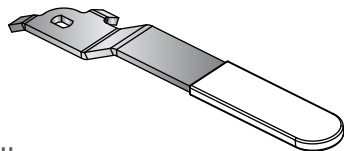

The 'POINTER' handle

Habonim's standard handle for valves without an ISO 5211 top pad.

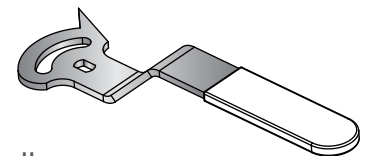

The 'ADJUSTABLE' handle

Habonim's special handle for manually controlled valves. It is supplied as part of a kit that includes a lock-in-place mechanism and a mirror-polished scale for clear identification of the valve's angular position. To specify a valve with the ADJUSTABLE handle add the '-ADJ' suffix to the valve code.



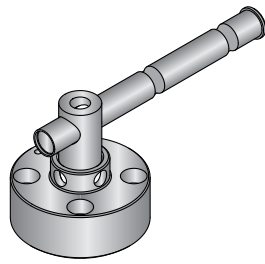

The T-Handle (TH)

Habonim's special handle designed for trailers with its compact footprint and lockable option. Available in the following Habonim high-pressure TPED certified series: 24, H24, H25 and H29.

The rod can be moved from side to side to increase leverage for a better user interface experience.

To specify a valve with the T-Handle, add the '-TH' suffix to the valve code.



The Oval handle (OVL)

Habonim's special handle designed to avoid unintentional movement of the valve handle. It is also used in confined spaces where the handle must not protrude beyond the valve's Face-to-Face plate. To specify a valve with the OVAL handle add the '-OVL' suffix to the valve code.

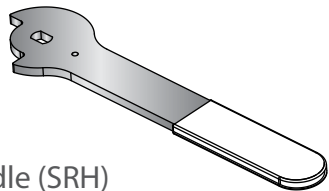

The Spring Return Handle (SRH)

An extra thick handle design to withstand the severe impact during valve closing. This handle is part of the SRH unit.

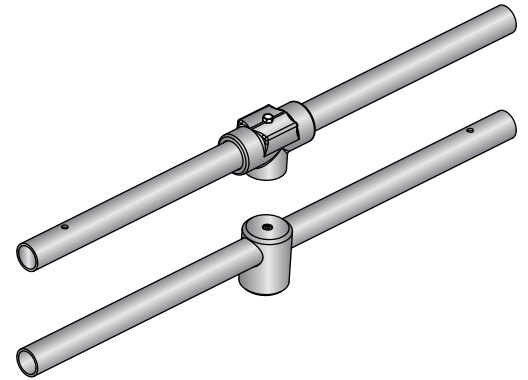

Habonim's standard handle for large valves (2½" and above)

Habonim's standard handle for large (2½" and above) cryogenic, high pressure and metal-seated valves, and for large (3" and above) standard valves. It provides a firm grip and smooth operation. The maximum force required at the handle-end to apply the breakaway torque shall not exceed 360 N (80 lbf). Habonim supplies valves with 2½" standard port and above for manual operation with handles attached to or packed with the valve. (with the exemption of 47 series which is for 3" standard port and above). If the valve is to be automatically actuated, Habonim removes the handle and prepares the valve stem seal accordingly. To specify a valve prepared for automated actuation, add the '-BS' (bare shaft) suffix to the valve code. The '-BS' suffix does not apply to valves size up to and including 2.







INDUSTRIAL VALVES

General	38
Trunnion	
Top Entry	41
3 piece	45
2 piece	55
Floating Ball	
3 piece	65
Flanged	79
DS (DBB) 3 piece	91
DS (DBB) Flanged	97
Multiport	101
Diverter Side Entry 3 piece	137
Diverter Side Entry Flanged	149
Flush Tank	161

INDUSTRIAL VALVES

General



Habonim's Industrial valves product line are subject to the general Habonim valves design, materials, practices, methodologies and certifications – for more information, see Valves General chapter.



Habonim General use Industrial valves are equipped with the Total HermetiX integrity package for superior sealing, safety and environmental care (for some series).

Habonim's wide range of industrial ball valves are in service for many decades and have been evolved to guarantee superb long-lasting performances in demanding applications as well as for general use. The standard basic valve construction offered by Habonim is an all-in-one high-end industrial valve that meets the latest safety, environmental, durability and maintainability requirements of modern industrial systems, piping and equipment.

Habonim's standard valves are supplied with the Total HermetiX integrity package that offers superior valve construction with a higher quality level and a unified design approach to allow minimal variants of valve parts to support a wider range of applications that guarantee higher availability, lower level of spare parts and reduced total cost of ownership.

Features

Total HermetiX:

- Zero fugitive-emission no maintenance stem sealing
- Double body sealing
- Fire safe
- 100% tested
- 100% materials & processing back-tracking

End Connections Variety:

- Wide range of end connections available for assembly on a generic center section in 3 piece series, standard or full port.
- Flanged connections comply with ANSI B16.5 with standard or full port valves.

Certifications

Type tested certified by leading certification bodies and other on request (for part of the series).



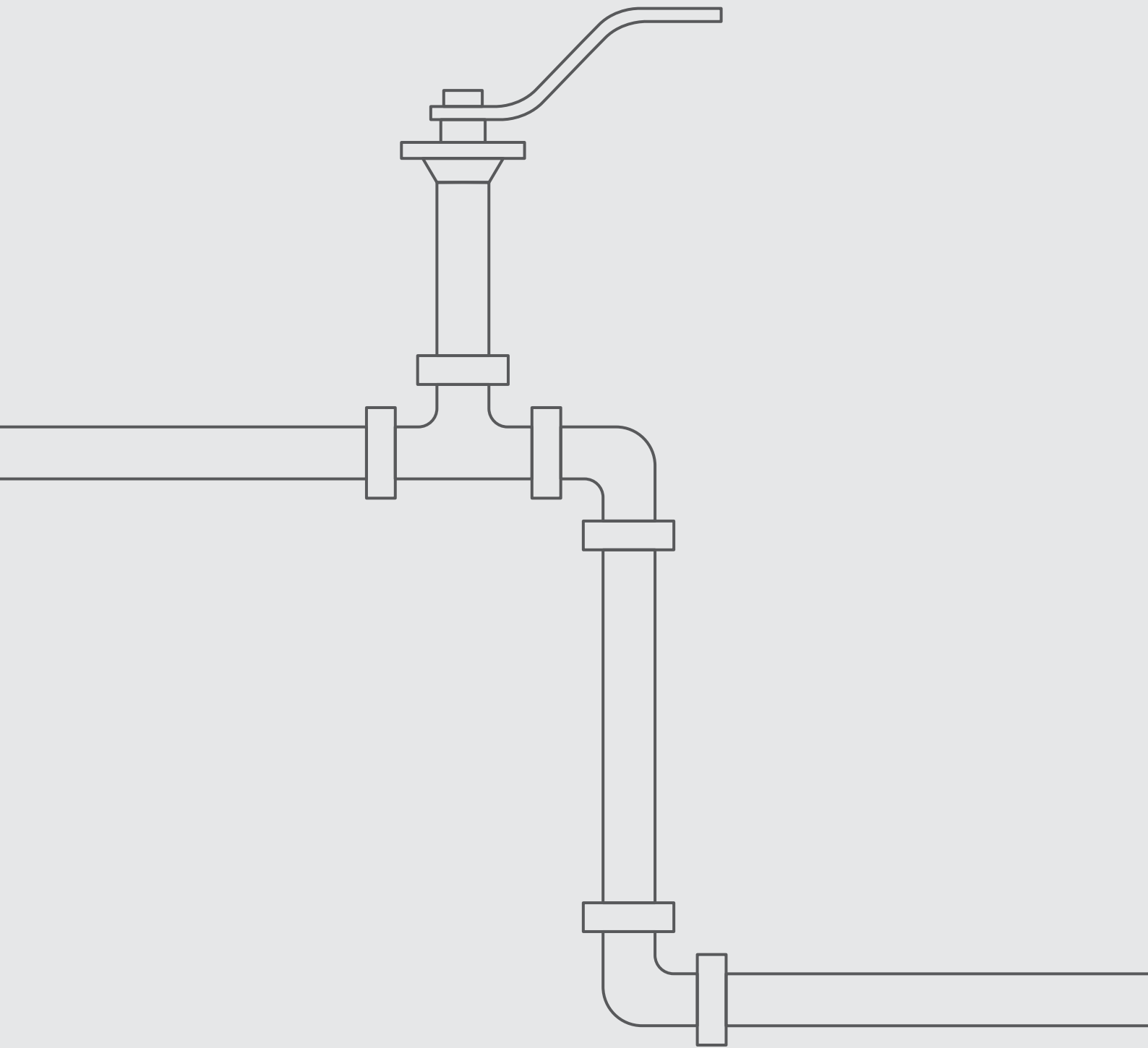



TRUNNIION

TOP ENTRY

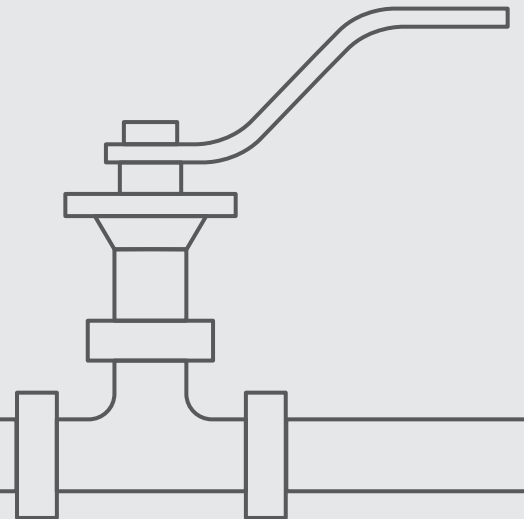

Top Entry Trunnion Mounted Ball Valve

Valve Dimensions

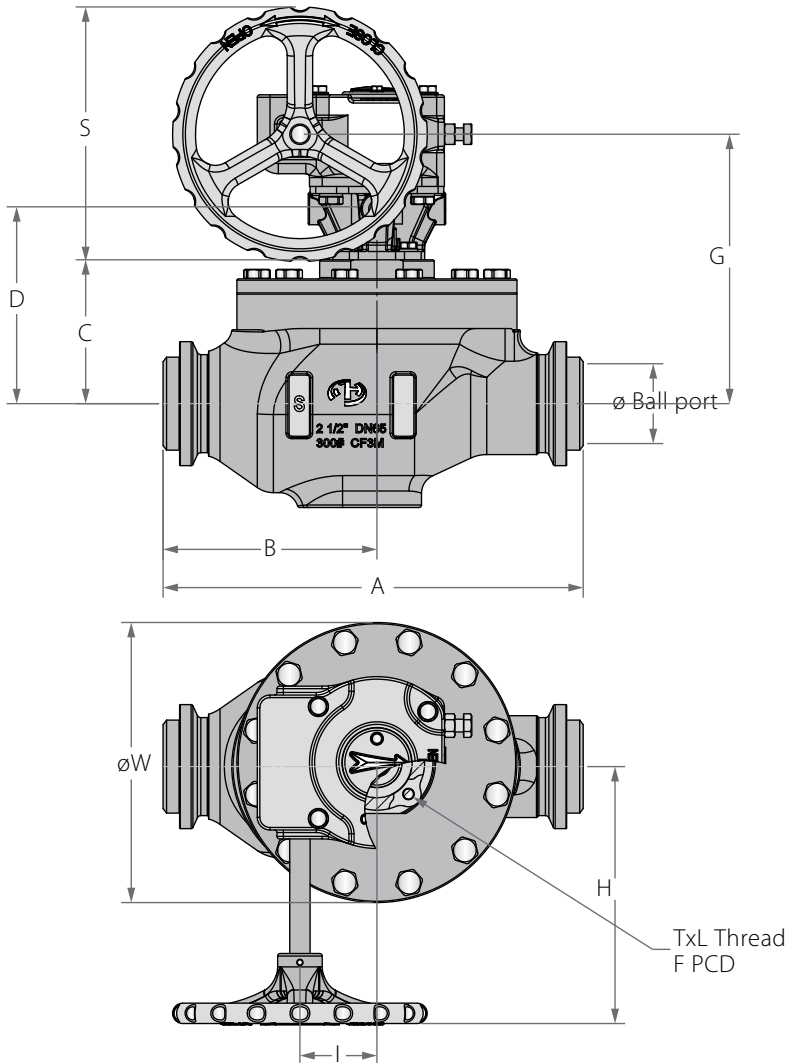

Gear operated

The C52 valves are operated and supplied with factory calibrated gears or CompAct actuators.

Standard stem tops

DD Type for sizes 1½" - 2½"

Stem flats show valve ball position

Square Type for sizes 2" - 6"

Stem groove shows valve ball position

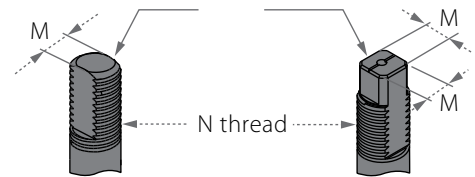

Preparation for actuation

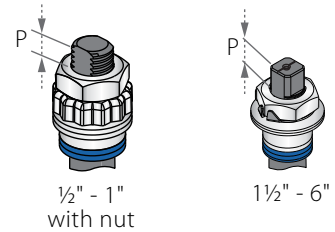

Full Port	Units	Ball port	A	B	C	D	G*	H*	I*	S*	W	M	N	P	F	TxL	Weight kg/lb	KV CV	
DN40	mm	38.2	241.0	129.0	88.6	118.0	177.2	192.0	52.0	200	169.0	8.7	¾" - 18 UNF	7.1	F05	50.0	M8x9	11.5	164
1½"	inch	1.5	9.49	5.08	3.49	4.65	6.98	7.56	2.05	7.87	6.65	0.34		0.28				1.97	25.4
DN50	mm	50.8	292.0	151.0	103.9	145.5	192.5	197.0	52.0	250.0	43.0	13.9	M20x2.5	13.9	F07	70.0	M10x15	20.5	327
2"	inch	2.0	11.50	5.94	4.09	5.73	7.58	7.76	2.05	9.84	1.69	0.55		0.55				2.76	45.2
DN65	mm	62.7	330.0	168.0	113.0	154.6	211.6	208.2	60.5	300.0	220.0	13.9	M20x2.5	13.2	F07	70.0	M12x15	27.8	668
2½"	inch	2.5	12.99	6.61	4.45	6.09	8.33	8.20	2.38	11.81	8.66	0.55		0.52				2.76	61.3
DN80	mm	74.0	356.0	186	142.5	189.1	263.5	270.0	60.5	400.0	240.0	18.9	1" - 14 UNS	18.3	F10	102.0	M12x15	38.5	823
3"	inch	3.0	14.02	7.32	5.61	7.44	10.37	10.63	2.38	15.75	9.45	0.74		0.72				4.02	84.9
DN100	mm	100.0	432.0	220.0	155.3	201.8	276.3	489.0	70.0	400.0	305.0	18.9	1" - 14 UNS	18.3	F10	102.0	M12x15	64.0	1678
4"	inch	4.0	17.01	8.66	6.11	7.94	10.88	19.25	2.76	15.75	12.01	0.74		0.72				4.02	141.1
DN150	mm	150.0	559.0	280.0	214.7	284.1	370.2	372.0	122.5	600.0	410.0	28.5	1½" - 12 UNF	28.5	F12	125.0	M16x20	158.0	4199
6"	inch	6.0	22.01	11.02	8.45	11.19	14.57	14.65	4.82	23.62	16.14	1.12		1.12				4.92	348.3

* Gear position dimensions may be a subject for changes for some applications weight of the valve BS (whithout gear & MK)

Full Port	Machinery Gear	Heavy Duty Gear
DN40 / 1½"	GJE570-GC30L0-09O22	GAE550-GC25L0-11O22
DN50 / 2"	GJE570-GC30L0-09O22	GAE550-GC25L0-11O22
DN65 / 2½"	GJE570-GC30L0-09O22	GAE550-GC25L0-11O22

Full Port	Machinery Gear	Heavy Duty Gear
DN80 / 3"	GJE930-GC50L0-11O27	GAE01K-GC30L0-11O27
DN100 / 4"	GJE930-GC50L0-11O27	GAE01K-GC30L0-11O27
DN150 / 6"	GJW2K6-GD70L0-16O46	GAE02K-GC40L0-16O36

* See Habonim Gears Catalogue for more information



Top Entry Trunnion Mounted Ball Valve

Components & Materials

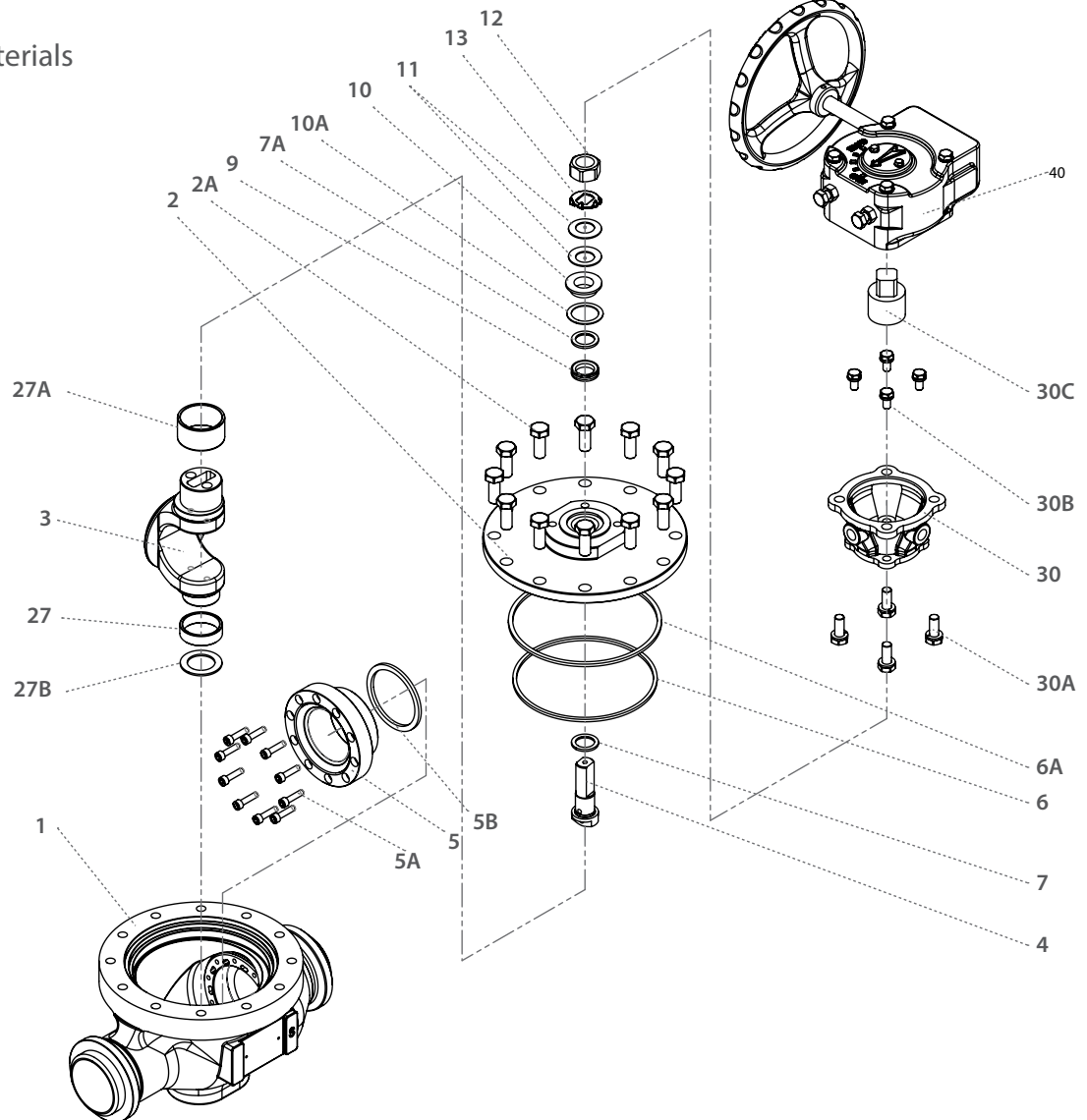

Item	Description	Material specifications	Qty.
1	Body	Acc. Ordering Code	1
2	Cover	Acc. Ordering Code	1
2A	Cover Bolts	S.Steel	12
3	Ball	S.Steel	1
4	Stem	High Strength S.Steel	1
5*	Hybrid Seat	S.Steel	1
5A*	Seat Bolts	S.Steel	10
5B*	Seat Seal	Graphite	1
6*	Cover Inner Seal	TFM	1
6A*	Cover Outer Seal	Graphite	1
7*	Stem Thrust Seal	PCTFE	1
7A*	Anti-Abrasion Ring	PCTFE	1
9*	Stem Seal	TFM	1
10	Follower	S.Steel	1
10A*	Slide Bearing	S.Steel	1

Item	Description	Material specifications	Qty.
11	Disc Spring	S.Steel	2
12	Stem Nut	S.Steel	1
13	Locking Clip (Tab Lock Washer For 2" And Up)	S.Steel	1
27*	Upper Ball Radial Bearing	S.Steel	1
27A	Lower Ball Radial Bearing	S.Steel	1
27B*	Lower Thrust Bearing	S.Steel + PTFE	1
30	Bridge	S.Steel	1
30A	Bridge Upper Bolts	S.Steel	4
30B	Bridge Lower Bolts	S.Steel	4
30C	Lower Thrust Washer	S.Steel	1
40	Bonnet Bolt	---	1

* Maintenance kit components



Top Entry Trunnion Mounted Ball Valve - Ordering Code System

"Mandatory option" options are marked with **green background** | "Standard offer" options are marked with **light green background**

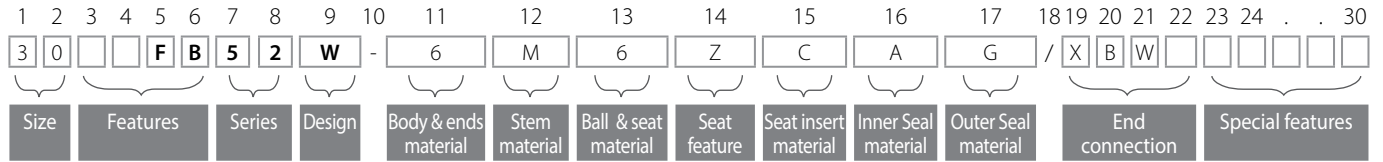

Size (1-2)		
Code	inch	mm
15	1½"	40
20	2"	50
25	2½"	65
30	3"	80
40	4"	100
60	6"	150

Features (3-6)	
B	Full port
F	Fire safe

Series (7-8)	
52	ASME #300 Top Entry

Design (9)	
W	Total HermetiX Integrity package

Body & Bonnet (11)	
6	S. Steel

Stem material (12)	
M	High Strength S. Steel

Ball & seat material (13)	
6	S. Steel

Seat feature (14)	
Z	Eccentric C-Ball

Seat insert (15)	
C	PCTFE

Primary bonnet seal (16)	
A	TFM

Outer Seal material (17)	
G	Graphite

End Connection (19-22)	
XBW	Butt weld ASME B16.25 SCH40
XBW10	Butt weld ASME B16.25 SCH10
XBW80	Butt weld ASME B16.25 SCH80
ETI1.6	Butt weld ISO 1127, 1.6mm
ETI2.0	Butt weld ISO 1127, 2.0mm
ETI2.3	Butt weld ISO 1127, 2.3mm

Special Features (24-30)	
--------------------------	--

91

92

93

94



Industrial Valves

TRUNNIION

3 PIECE

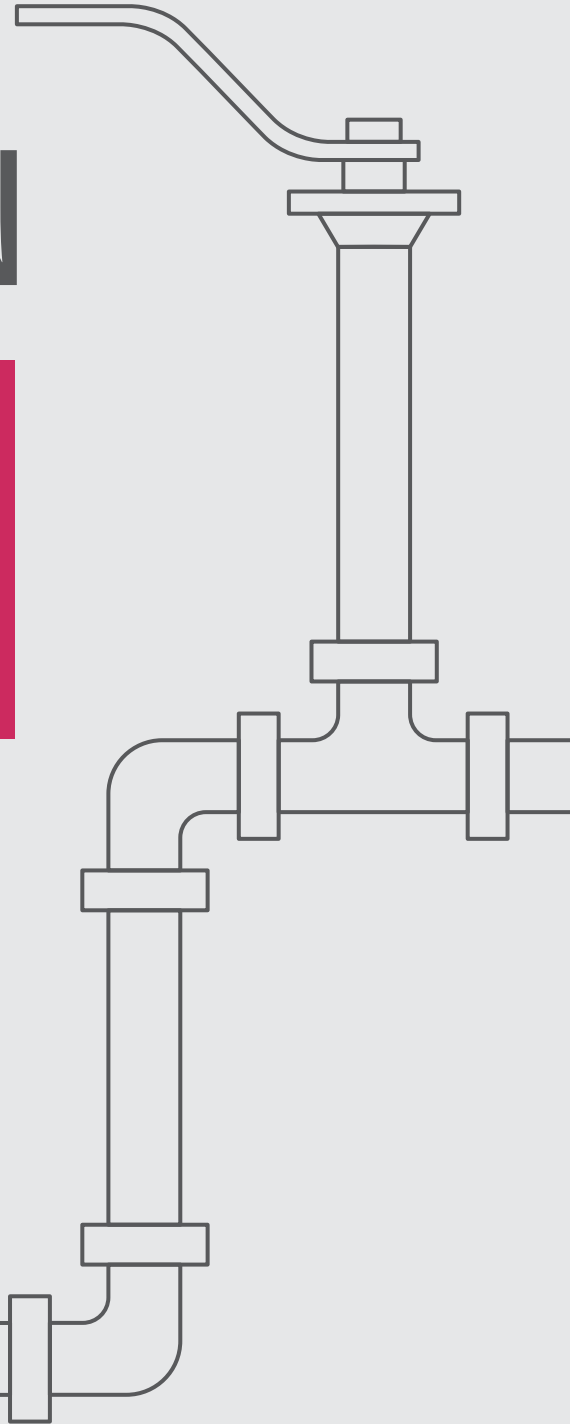

Trunnion Mounted Ball 3 Piece

Valve Dimensions

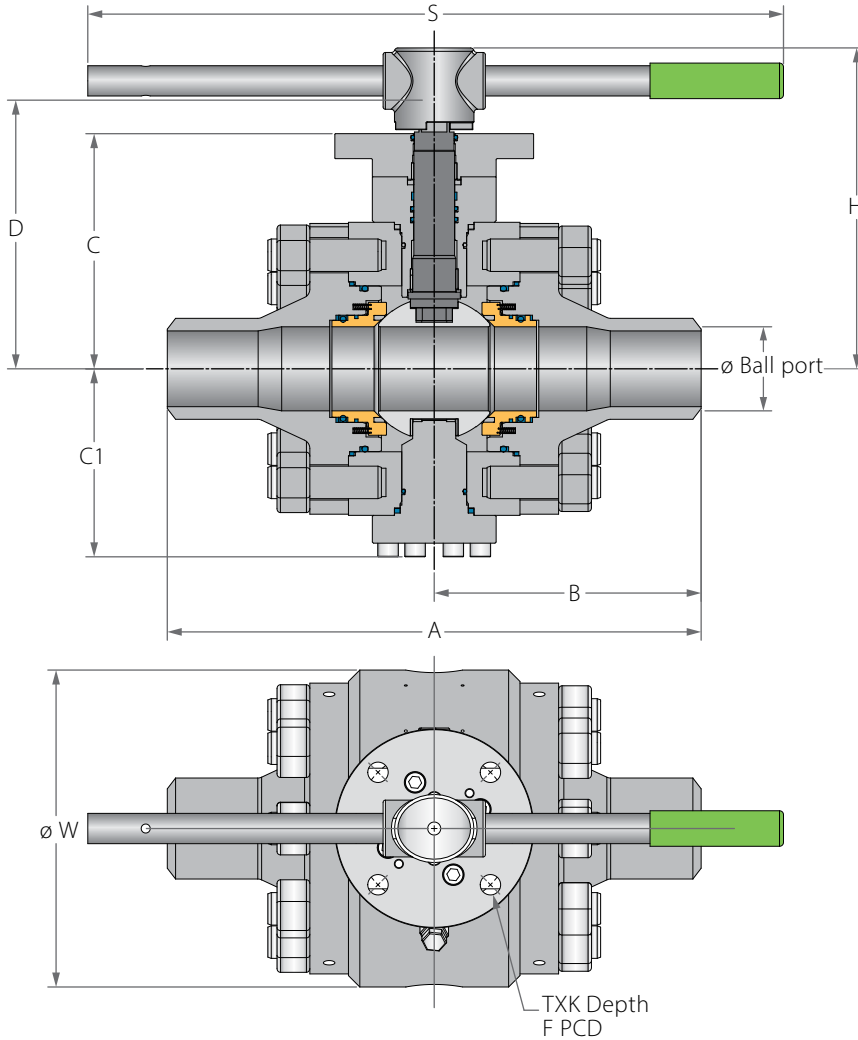

Preparation for actuation

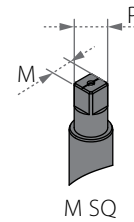

Std. port	Full port	Unit	Ball port	A		B		C	C1	D	W		Msq	Psq	H	S	F	TxL	Weight kg/ib		Kv / Cv		
				150	300	150	300				150	300							Msq	Psq	150	300	150
DN80	DN50	mm	49.0	216.0	216.0	108.0	108.0	127.0	91.50	144.50	169.0	169.0	17.0	22.0	196.0	401.0	F10	102.0	11 X15	20	22	400	363
3"	2"	inch	1.93	8.50	8.50	4.25	4.25	5.0	3.60	5.69	6.65	6.65	0.67	0.87	7.72	15.79		4.02	(4 holes)	44	49	463	420
DN100	DN80	mm	74.0	283.0	283.0	141.50	141.50	148.0	117.0	172.0	209.0	219.0	22.0	32.0	223.0	610.0	F12	125.0	13x15	43	46	1125	952
4"	3"	inch	2.91	11.14	11.14	5.57	5.57	5.83	4.61	6.77	8.23	8.62	0.87	1.26	8.78	24.02		4.92	(4 holes)	95	101	1300	1100
DN150	DN100	mm	100.0	305.0	305.0	152.50	152.50	171.0	139.0	198.50	259.0	268.0	27.0	35.0	247.50	610.0	F14	140.0	18x15	56	69	2154	1860
6"	4"	inch	3.94	12.01	12.01	6.0	6.0	6.73	5.47	7.81	10.20	10.55	1.06	1.38	9.74	24.02		5.51	(4 holes)	123	152	2490	2150
DN200	DN150	mm	150.0	457.0	457.0	228.50	228.50	254.0	191.0	290.50	355.0	359.0	36.0	46.20	356.50	916.0	F16	165.0	22x25	168	181	4723	4628
8"	6"	inch	5.91	17.99	17.99	9.0	9.0	10.0	7.52	11.44	13.98	14.13	1.42	1.82	14.04	36.06		6.50	(4 holes)	370	399	5460	5350



Trunnion Mounted Ball 3 Piece

Valve Dimensions

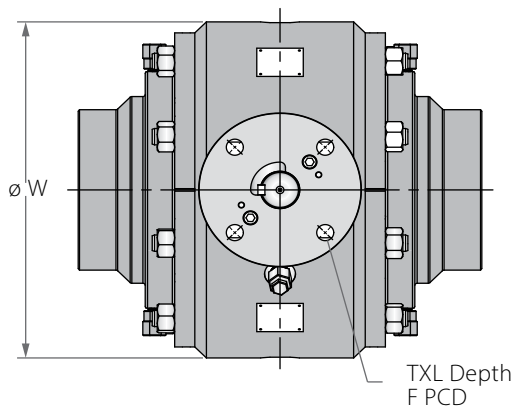
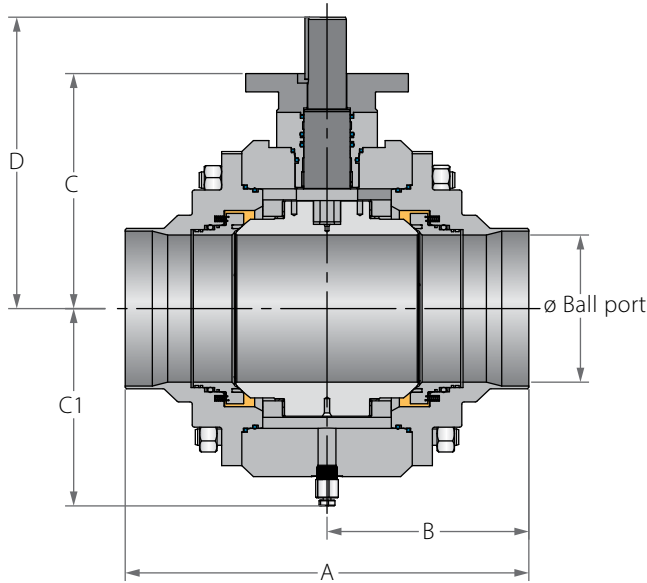

Preparation for actuation

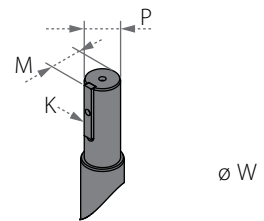

Std. port	Full port	Unit	Ball port	A		B		C		C1		D		W		P		M		K		F	TxL	Weight kg/lb		Kv / Cv		
				150	300	150	300	150	300	150	300	150	300	150	300	150	300	150	300	150	300			150	300	150	300	
DN250 10"	DN200 8"	mm	201.0	521.0	521.0	260.50	260.50	325.0	305.0	247.0	232.0	405.50	379.50	459.0	459.0	50.0	50.0	54.0	61.0	14.0	14.0	F16	165.0	22x25 (4 holes)	305	335	9273	8737
		inch	7.91	20.51	20.51	10.26	10.26	12.80	12.01	9.72	9.13	15.96	14.94	18.07	18.07	1.97	1.97	2.13	2.40	0.55	0.55		6.50	672	739	10720	10100	
DN300 12"	DN250 10"	mm	252.0	559.0	559.0	279.50	279.50	353.0	359.0	297.0	299.0	430.0	454.0	550.0	550.0	50.0	60.0	54.0	65.50	14.0	18.0	F25	254.0	18x25 (8 holes)	517	542	15224	14792
		inch	9.92	22.01	22.01	11.0	11.0	13.90	14.13	11.69	11.77	16.93	17.87	21.65	21.65	1.97	2.36	2.13	2.58	0.55	0.71		10.0	1140	1195	17600	17100	
DN350 14"	DN300 12"	mm	303.0	635.0	635.0	317.50	317.50	388.0	368.0	324.0	305.0	468.50	464.0	610.0	610.0	60.0	60.0	63.50	65.50	18.0	18.0	F25	254.0	18x25 (8 holes)	792	833	23096	22404
		inch	11.93	25.0	25.0	12.50	12.50	15.28	14.49	12.76	12.01	18.44	18.27	24.02	24.02	2.36	2.36	2.50	2.58	0.71	0.71		10.0	1746	1836	26700	25900	
DN400 16"	DN350 14"	mm	334.0	762.0	762.0	381.0	381.0	399.0	425.0	422.0	425.0	496.0	522.0	645.0	645.0	72.0	72.0	78.0	76.50	20.0	20.0	F30	254.0	22x30 (8 holes)	897	985	27940	26729
		inch	13.15	30.0	30.0	15.0	15.0	15.71	16.73	16.61	16.73	19.53	20.55	25.39	25.39	2.83	2.83	3.07	3.01	0.79	0.79		10.0	1978	2172	32300	30900	

Trunnion Mounted Ball 3 Piece

Valve Dimensions

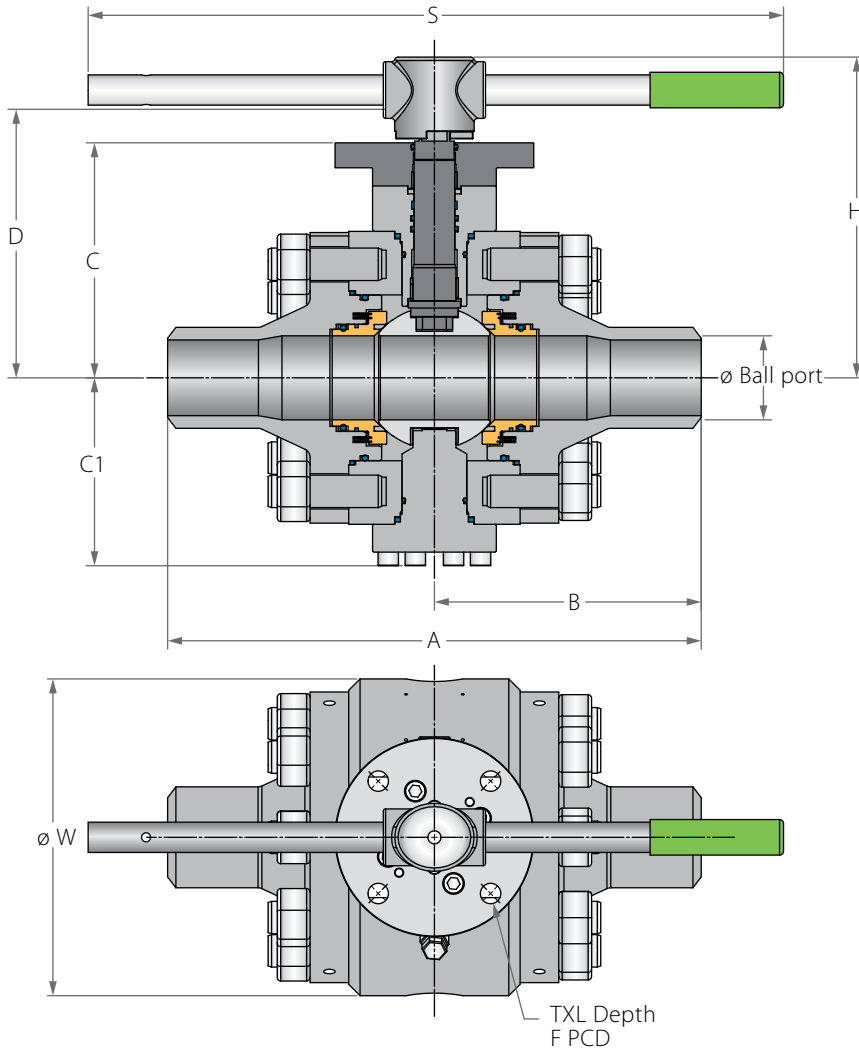

Preparation for actuation

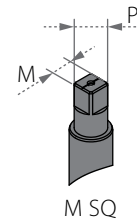

Std. port	Full port	Unit	Ball port	A		B		C		C1		D		W		M _{sq}	P _{sq}	H	S	F		TxL	Weight kg/lb				Kv / Cv	
				600	900	600	900	600	900	600	900	600	900	600	900					600	900		600	900				
DN80	DN50	mm	49.0	292.0	368.0	146.0	184.0	144.0	148.50	119.0	263.0	168.50	182.50	205.0	205.0	22.0	28.0	219.50	401.0	F12	125.0	13X15 (4 holes)	41	58	329	294		
3"	2"	inch	1.93	11.50	14.49	5.75	7.24	5.67	5.85	4.69	10.35	6.63	7.19	8.07	8.07	0.87	1.10	8.64	15.79		4.92		90	128	380	340		
DN100	DN80	mm	74.0	356.0	381.0	178.0	190.50	191.0	214.0	160.0	152.70	215.0	237.50	270.0	275.0	22.0	28.0	266.0	610.0	F14	140.0	22x24 (4 holes)	89	100	874	822		
4"	3"	inch	2.91	14.02	15.0	7.01	7.50	7.52	8.43	6.30	6.01	8.46	9.35	10.63	10.83	0.87	1.10	10.47	24.02		5.51		196	220	1010	950		
DN150	DN100	mm	100.0	432.0	457.0	216.0	228.50	217.0	193.0	184.0	184.0	246.50	259.0	325.0	325.0	27.0	36.0	316.50	916.0	F16	165.0	22x25 (4 holes)	128	171	1557	1471		
6"	4"	inch	3.94	17.01	17.99	8.50	9.0	8.54	7.60	7.24	7.24	9.70	10.20	12.80	12.80	1.06	1.42	12.46	36.06		6.50		282	377	1800	1700		
DN200	DN150	mm	150.0	559.0	610.0	279.50	305.0	282.50	368.0	214.50	224.0	320.50	463.0	400.0	435.0	36.0	48.20	385.0	916.0	F16	165.0	22x25 (8 holes)	277	335	3893	3823		
8"	6"	inch	5.91	22.01	24.02	11.0	12.01	11.12	14.49	8.44	8.82	12.62	18.23	15.75	17.13	1.42	1.90	15.16	36.06		6.50		611	739	4500	4420		



Trunnion Mounted Ball 3 Piece

Valve Dimensions

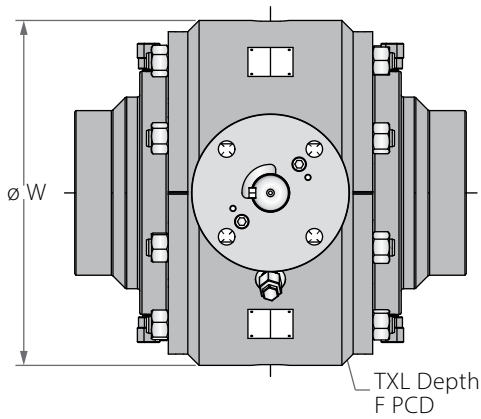
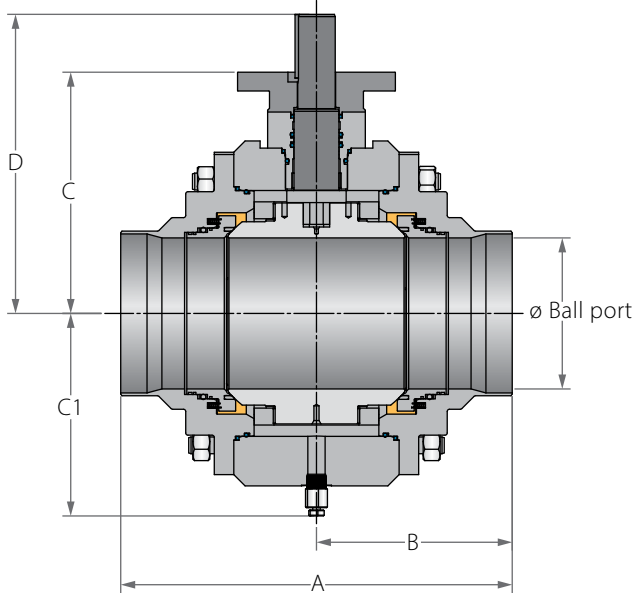

Preparation for actuation

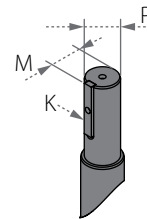

Std. port	Full port	Unit	Ball port	A		B		C		C1		D		W		P	M	K	F	TxL	Weight kg/lb		Kv / Cv		
				600	900	600	900	600	900	600	900	600	900	600	900						600	900	600	900	
DN250	DN200	mm	201.0	660.0	737.0	330.0	368.50	312.0	307.0	263.0	263.0	409.0	403.0	500.0	519.0	72.0	76.50	20.0	F25	254.0	18x25	486	520	7742	7344
10"	8"	inch	7.91	25.98	29.02	12.99	14.51	12.28	12.09	10.35	10.35	16.10	15.87	19.69	20.43	2.83	3.01	0.79		10.0	(8 holes)	1071	1146	8950	8490
DN300	DN250	mm	252.0	787.0	838.0	393.50	419.0	374.0	393.0	310.0	347.0	471.0	490.0	595.0	609.0	72.0	76.50	20.0	F25	254.0	18x25	758	945	12543	12110
12"	10"	inch	9.92	30.98	32.99	15.49	16.50	14.72	15.47	12.20	13.66	18.54	19.29	23.43	23.98	2.83	3.01	0.79		10.0	(8 holes)	1671	2083	14500	14000
DN350	DN300	mm	303.0	838.0	965.0	419.0	482.50	402.0	419.0	344.0	361.0	499.0	544.0	695.0	709.0	72.0	76.50	20.0	F25	254.0	18x35	1183	1398	19809	18598
14"	12"	inch	11.93	32.99	37.99	16.50	19.0	15.83	16.50	13.54	14.21	19.65	21.42	27.36	27.91	2.83	3.01	0.79		10.0	(8 holes)	2608	3082	22900	21500
DN400	DN350	mm	334.0	889.0	-	444.50	-	435.0	-	412.0	-	565.0	-	730.0	-	80.0	87.0	22.0	F30	298.0	22x35	1530	-	24739	23528
16"	14"	inch	13.15	35.0	-	17.50	-	17.13	-	16.22	-	22.24	-	28.74	-	3.15	3.43	0.87		11.73	(8 holes)	3373	-	28600	27200

Trunnion Mounted Ball 3 Piece

Components & Materials

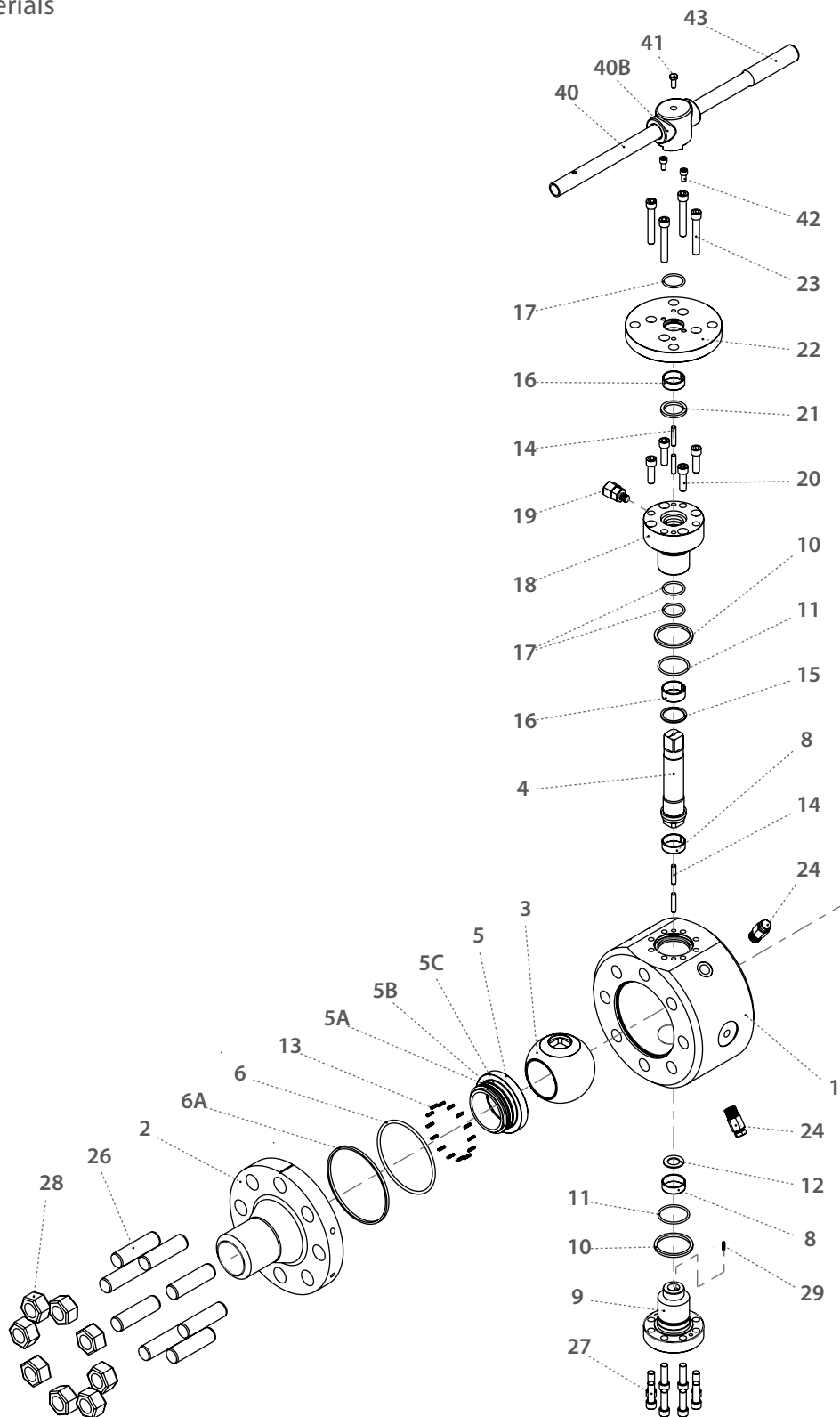



Trunnion Mounted Ball 3 Piece

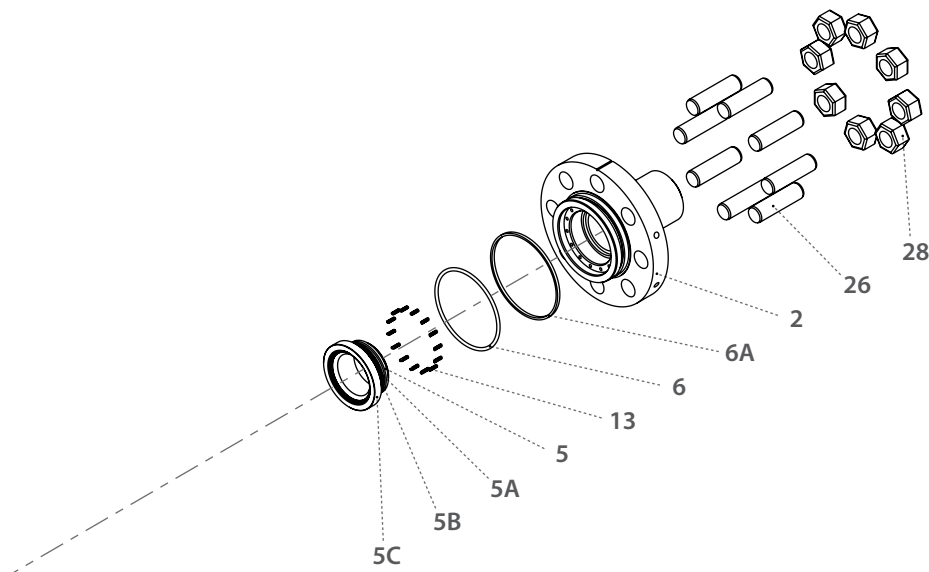

Item	Description	Material specification	Qty.
1	Body	Acc. Ordering Code	1
2	End	Acc. Ordering Code	2
3	Ball	Acc. Ordering Code	1
4	Stem	Acc. Ordering Code	1
5*	Seat	Acc. Ordering Code	2
5A	Seat Insert	Acc. Ordering Code	2
5B*	Seat Seal	HNBR, VITON	2-4
5C*	Seat Fire Safe Seal	Graphite	2
6*	Body Inner Seal	HNBR, VITON	2
6A*	Body Outer Seal	Graphite	2
8*	Ball Bearing	S.Steel 316+PTFE	2
9	Trunnion Plate	S.Steel / C.Steel	2
10*	Gland Plate Fire Safe Seal	Graphite	1
11*	Gland Plate Seal	HNBR, VITON	1
12*	Ball Thrust Washer	S.Steel 316+PTFE	2
13	Seat Spring	INCONEL X750	10-24
14	Gland Pin (not shown)	S.Steel / C.Steel	12
15*	Stem Thrust Washer	S.Steel 316+PTFE	1
16*	Stem Bearing	S.Steel 316+PTFE	1
16A	ISO Plate Bearing	S.Steel 316+PTFE	1

Item	Description	Material specification	Qty.
17*	Stem Seal	HNBR, VITON	2
18	Gland Plate	S.Steel / C.Steel	1
19	Stem Grease Fitting	S.Steel	1
20	Lower Gland Bolts	A193-B8M / A320 L7	2-6
21*	Stem Fire Safe Seal	Graphite	1
22	Iso Plate	S.Steel / C.Steel	1
23	Upper Gland Bolts	A193-B8M / A320 L7	2
24	Plug Valve	S.Steel	2
25	Seat Grease Fitting + Check Valve	S.Steel	4
26	Body Studs	A193-B8M / A320 L7	8-40
27	External Trunnion Bolts	A320 L7, A193 B8M	4-12
28	Body Nut	A194-8M / A194 L7	8-40
29	Anti-Static Spring	INCONEL X750	1
40	Pipe Handle	S.Steel	1
40B	Wrench Head	S.Steel	1
41	Wrench Head Bolts	S.Steel	1
42	Stop Bolt	S.Steel	2
43	Sleeve	PCV	1

* Maintenance kit component

Trunnion Mounted Ball 3 Piece

Components & Materials

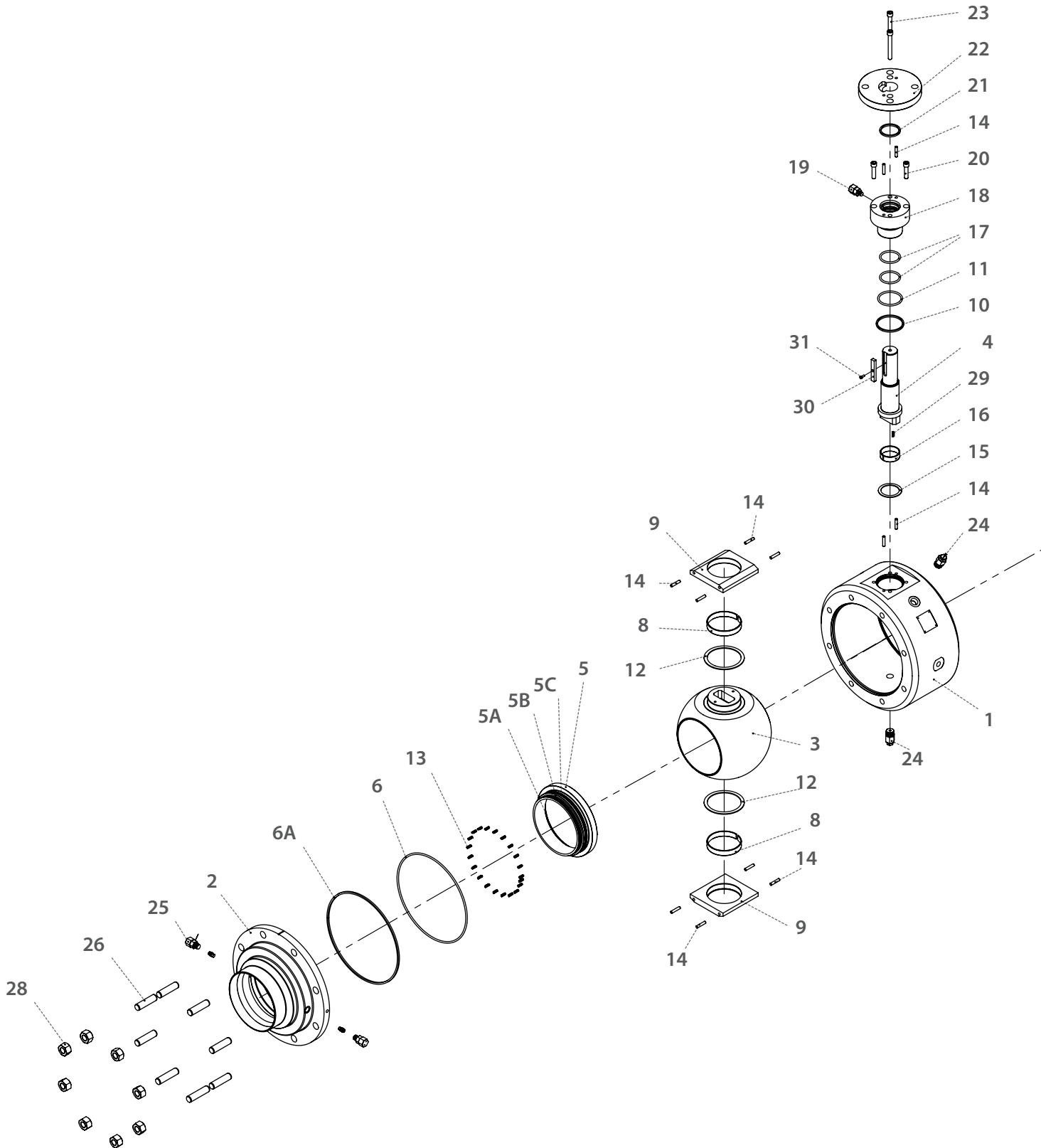

91

92

93

94

10"-16" | DN250-DN400
CLASS 150/300/600/900

Trunnion Mounted Ball 3 Piece

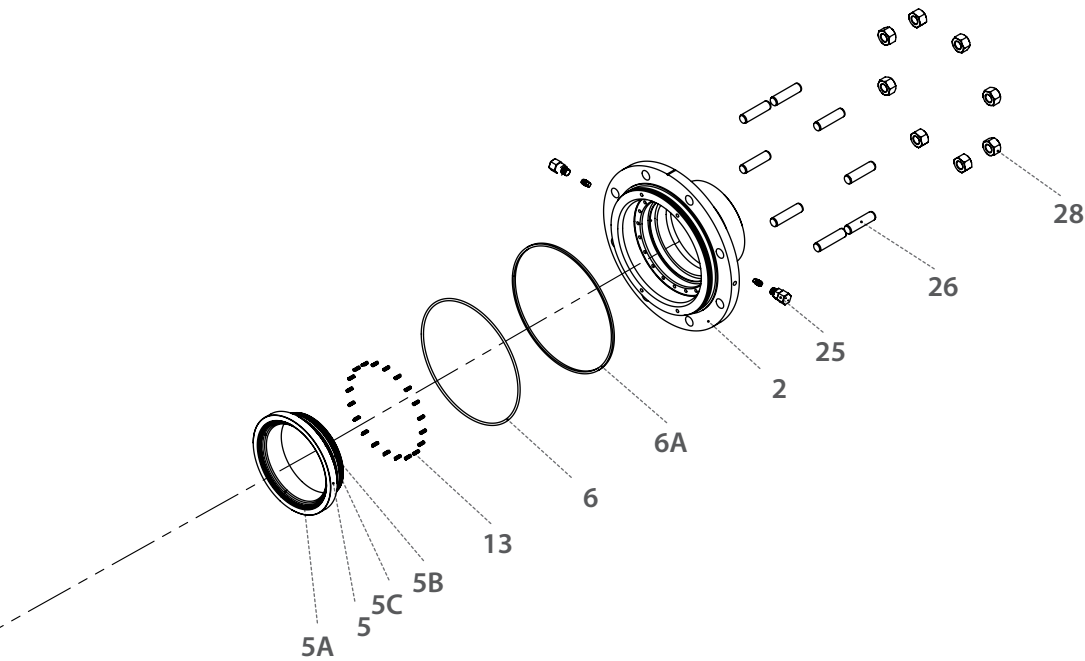

Item	Description	Material specification	Qty.
1	Body	Acc. Ordering Code	1
2	End	Acc. Ordering Code	2
3	Ball	Acc. Ordering Code 1	1
4	Stem	Acc. Ordering Code	1
5*	Seat	Acc. Ordering Code	2
5A*	Seat Insert	Acc. Ordering Code	2
5B*	Seat Seal	HNBR, VITON	2-4
5C*	Seat Fire Safe Seal	Graphite	2
6*	Body Inner Seal	HNBR, VITON	2
6A*	Body Outer Seal	Graphite	2
8*	Ball Bearing	S.Steel 316L+PTFE	2
9	Trunnion Plate	S.Steel / C.Steel	2
10*	Gland Plate Fire Safe Seal	Graphite	1
11*	Gland Plate Seal	HNBR, VITON	1
12*	Ball Thrust Washer	S.Steel 316L+PTFE	2
13	Seat Spring	Inconel X750	10-24
14	Gland Pin (not shown)	S.Steel / C.Steel	12

Item	Description	Material specification	Qty.
15*	Stem Thrust Washer	S.Steel 316L+PTFE	1
16*	Stem Bearing	S.Steel 316L+PTFE	1
17*	Stem Seal	HNBR, VITON	2
18	Gland Plate	S.Steel / C.Steel	1
19	Stem Grease Fitting	S.Steel	1
20	Lower Gland Bolts	A193-B8M / A320 L7	2-6
21*	Stem Fire Safe Seal	Graphite	1
22	Iso Plate	S.Steel / C.Steel	1
23	Upper Gland Bolts	A193-B8M / A320 L7	2-6
24	Plug Valve	S.Steel	2
25	Seat Grease Fitting + Check Valve	S.Steel	4
26	Body Studs	A193-B8M / A320 L7	8-40
28	Body Nuts	A194-8M / A194 L7	8-40
29	Anti-Static Spring	Inconel X750	1
30	Stem Key	S.Steel / C.Steel	1
31	Stem Key Bolt	S.Steel / C.Steel	1

* Maintenance kit component



Trunnion Mounted Ball 3 Piece - Ordering Code System

"Mandatory option" options are marked with **green background** | "Standard offer" options are marked with **light green background**

1	2	3	4	5	6	7	8	9	10	11	12	13	14	15	16	17	18	19	20	21	22	23	24	.	.	30
6	0			F	B	9	1		-	4	6	4	D	V	V	G	/	1	5	0		-				
Size		Features				Series		Design		Body & ends material		Stem material	Ball material	Seat feature	Seat insert material	Inner Seal material	Outer Seal material	End connection				Special features				

Size (1-2)		
Code	inch	mm
20 *	2"	50
30	3"	80
40	4"	100
60	6"	150
80	8"	200
A0	10"	250
A2	12"	300
A4 **	14"	350
A6 ¹	16"	400

* Full port only

** not available at class 900

¹ A6 - std. port only

Features (3-6)	
F	Fire safe
B	Full port
H	Hydrogen Service

Series - 3 Piece (7-8)	
91	ASME B16.5 #150 (PN20)
92	ASME B16.5 #300 (PN50)
93	ASME B16.5 #600 (PN100)
94	ASME B16.5 #900 (PN150)

Design (9)	
Blank	(Stands for future designs)

Body & ends material (11)	
4	C. Steel A105
6	S. Steel 316
F	C. Steel A350 LF2
D	Duplex
K	Super Duplex

Stem material (12)	
6 *	S. Steel A479 316\316L
Q **	S. Steel A182 F6A
M ***	High Strength S. Steel
Z	Inconel 718
W	Hastelloy C-22
D	Duplex
K	Super Duplex

* for 91, 92 not for 93, 94

** for 93, not for 94

*** for 94

Ball material (13)	
6*	S. Steel A182 F316
4**	C. Steel A105+ENP
F	C. Steel A350 LF2+ENP

* S. Steel up to 4"

** C. Steel 6" and up

Seat feature (14)	
D	Double Piston Effect (DPE) (API 6D DIB-1)
S	Single Piston Effect (SPE) (API 6D DBB)
C	DPE & SPE combination (API 6D DIB-2)

Seat insert material (15)	
V	Devlon
P	CF PTFE
K	CF PEEK

Inner Seal material (16)	
V	Viton
H	HNBR

Outer Seal material (17)	
G	Graphite

End Connection (19-22)	
Welded ends	
XBW	Extended butt weld sch 40
XBW80	Extended butt weld sch 80
XBW160	Extended butt weld sch 160

Flanged	
150	ASME B16.5 #150
300	ASME B16.5 #300
600	ASME B16.5 #600
900	ASME B16.5 #900
PN16	DIN EN 1092-1 PN16
PN40	DIN EN 1092-1 PN40
PN63	DIN EN 1092-1 PN63
PN100	DIN EN 1092-1 PN100
PN160	DIN EN 1092-1 PN160

Flanged RTJ	
600RTJ	ASME B16.5 #600 RTJ
900RTJ	ASME B16.5 #900 RTJ

Welded	
Special Features (24-30)	
L *	Seat greasing point
D	Drain & Vent
Blank	Greasing point, Drain & vent is capped
PT **	Basic paint system
PT1	Offshore, Temp Ambient up to 93°C (200°F)
PT2	Offshore, up to 537°C (1000°F)

* for 6" Full Bore and up

** colors RAL 1018 or 7036

(other colors upon request)

In some applications the available options above are limited to specific sizes please consult with Habonim for details

81

82

83



Industrial Valves

TRUNNIION

2 PIECE

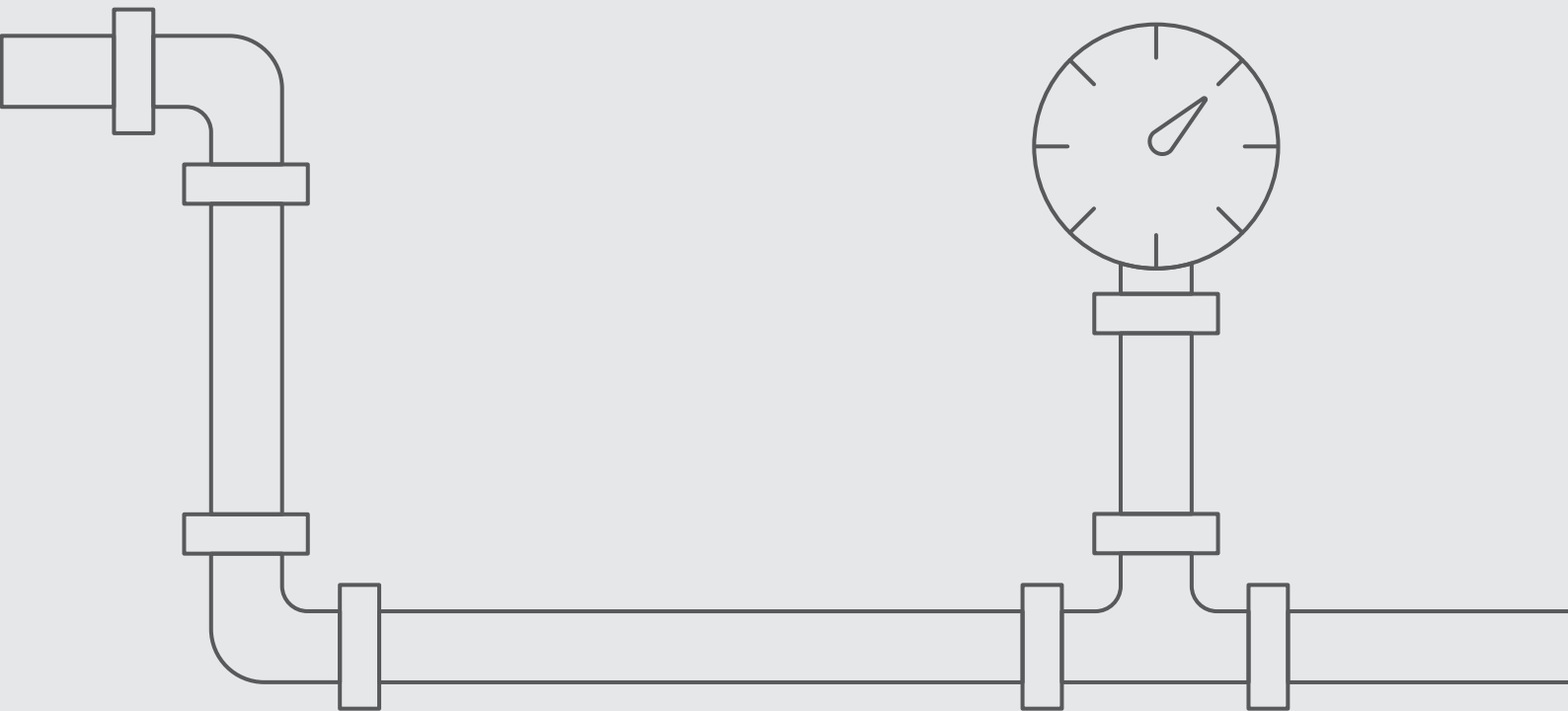

Trunnion Mounted Ball 2 Piece

Valve Dimensions

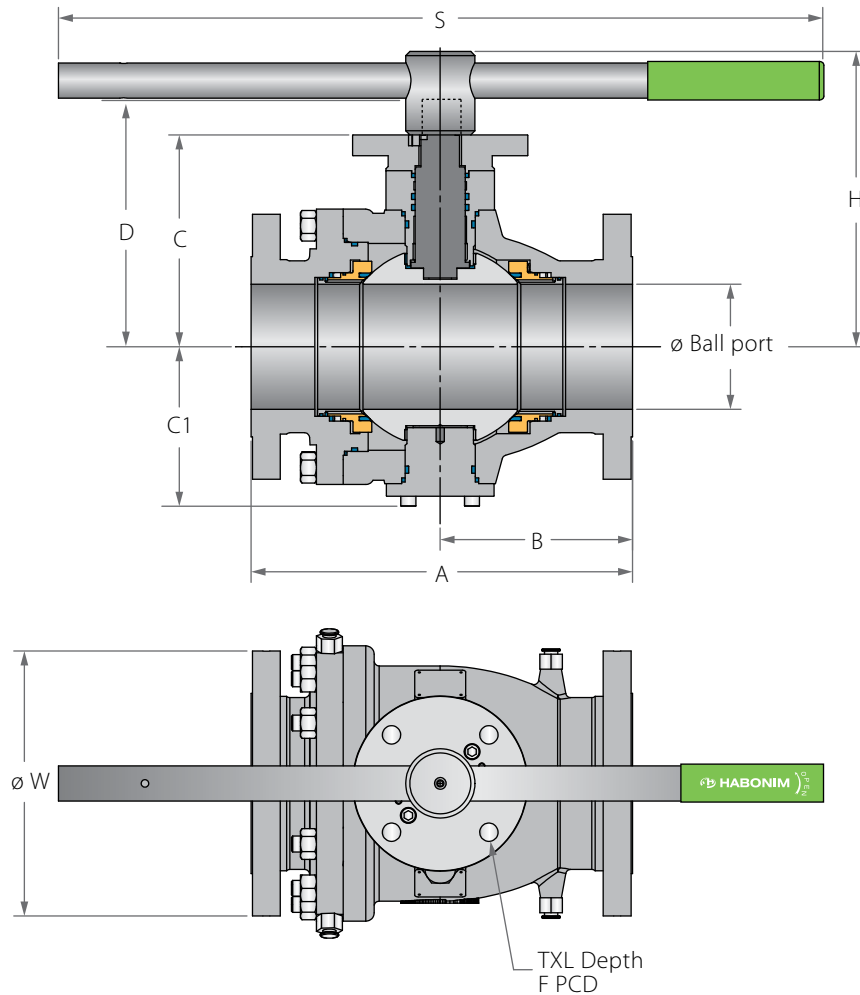

Preparation for actuation

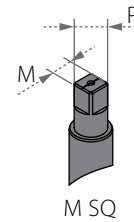

Full port	Unit	Ball port	A		B		C	C1	D	W		M SQ	P SQ	H	S	F	TxL	Weight kg/lb		Kv / Cv		
			150	300	150	300				150	300							150	300	150	300	
DN50	mm	49.0	178.0	216.0	89.0	108.0	127.0	91.50	144.50	150.0	165.0	17.0	22.0	196.0	401.0	F10	102.0	11x15	19	23	400	363
2"	inch	1.93	7.01	8.50	3.50	4.25	5.0	3.60	5.69	5.91	6.50	0.67	0.87	7.72	15.79		4.02	(4 holes)	42	51	463	420
DN80	mm	74.0	203.0	283.0	101.50	128.0	148.0	117.0	172.0	190.0	210.0	22.0	32.0	223.0	610.0	F12	125.0	13x15	33	44	1125	952
3"	inch	2.91	7.99	11.14	4.0	5.04	5.83	4.61	6.77	7.48	8.27	0.87	1.26	8.78	24.02		4.92	(4 holes)	73	97	1300	1100
DN100	mm	100.0	229.0	305.0	114.50	140.50	171.0	139.0	198.50	230.0	255.0	27.0	35.0	247.50	610.0	F14	140.0	18x15	49	69	2154	1860
4"	inch	3.94	9.02	12.0	4.51	5.53	6.73	5.47	7.81	9.06	10.04	1.06	1.38	9.74	24.02		5.51	(4 holes)	108	152	2490	2150
DN150	mm	150.0	394.0	403.0	185.0	230.40	254.0	191.0	290.50	280.0	320.0	36.0	46.20	356.50	916.0	F16	165.0	22x25	133	166	4723	4628
6"	inch	5.91	15.51	17.99	7.28	9.07	10.0	7.52	11.44	11.02	12.60	1.42	1.82	14.04	36.06		6.50	(4 holes)	293	366	5460	5350



Trunnion Mounted Ball 2 Piece

Valve Dimensions

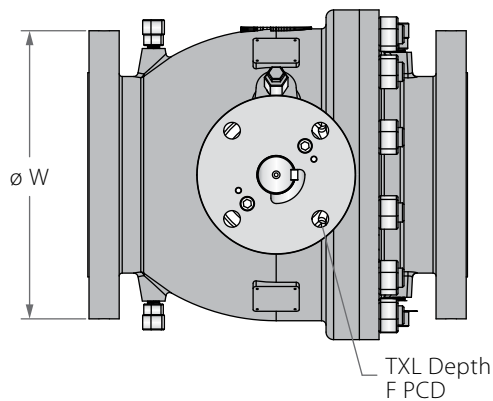
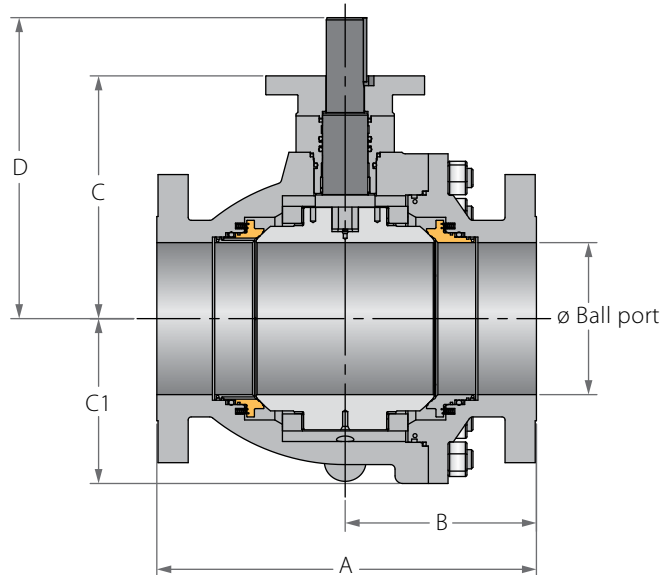

Preparation for actuation

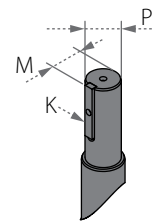

Full port	Unit	Ball port	A		B		C	C1	D	W		P	M	K	F	TxL	Weight kg/lb		Kv / Cv		
			150	300	150	300				150	300						150	300	150	300	
DN200	mm	201.0	457.0	502.0	228.50	251.0	325.0	247.0	405.50	345.0	380.0	50.0	54.0	14.0	F16	165.0	22x25	222	262	9273	8737
8"	inch	7.91	17.99	19.76	9.0	9.88	12.80	9.72	15.96	13.58	14.96	1.97	2.13	0.55		6.50	(4 holes)	489	578	10720	10100
DN250	mm	252.0	533.0	568.0	270.0	287.50	353.0	297.0	430.0	405.0	445.0	50.0	54.0	14.0	F25	254.0	18x25	358	424	15224	14792
10"	inch	9.92	20.98	22.36	10.63	11.32	13.90	11.69	16.93	15.94	17.52	1.97	2.13	0.55		10.0	(8 holes)	789	935	17600	17100
DN300	mm	303.0	610.0	648.0	298.0	313.0	388.0	324.0	468.50	485.0	520.0	60.0	63.50	18.0	F25	254.0	18x25	527	613	23096	22404
12"	inch	11.93	24.02	25.51	11.73	12.32	15.28	12.76	18.44	19.09	20.47	2.36	2.50	0.71		10.0	(8 holes)	1162	1351	26700	25900
DN350	mm	334.0	686.0	762.0	343.0	381.0	425.0	372.0	555.0	535.0	585.0	72.0	78.0	20.0	F30	298.0	22x30	794	896	27940	26729
14"	inch	13.15	27.01	30.0	13.50	15.0	16.73	14.65	21.85	21.06	23.03	2.83	3.07	0.79		11.73	(8 holes)	1750	1975	32300	30900

Trunnion Mounted Ball 2 Piece

Valve Dimensions

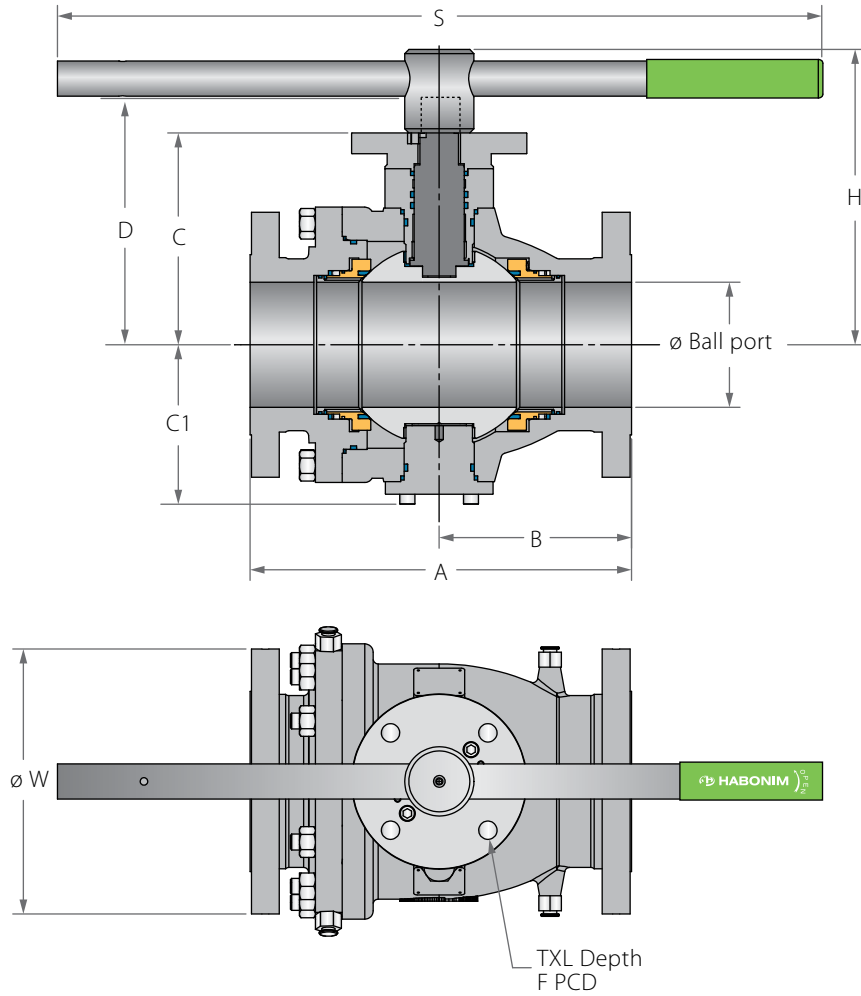

Preparation for actuation

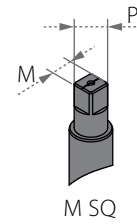

Full port	Unit	Ball port	A	B	C	C1	D	W	MSQ	PSQ	H	S	F	TxL	Weight kg/lb	Kv Cv	
DN50	mm	49.0	292.0	131.0	144.0	119.0	168.50	165.0	22.0	28.0	219.50	401.0	F12	125.0	13X15 (4 holes)	35	329
2"	inch	1.93	11.50	5.16	5.67	4.69	6.63	6.50	0.87	1.10	8.64	15.79		4.92		77	380
DN80	mm	74.0	356.0	161.0	191.0	160.0	215.0	210.0	22.0	28.0	266.0	610.0	F14	140.0	18X24 (4 holes)	71	874
3"	inch	2.91	14.02	6.34	7.52	6.30	8.46	8.27	0.87	1.10	10.47	24.02		5.51		157	1010
DN100	mm	100.0	432.0	216.0	217.0	184.0	246.50	275.0	27.0	36.0	316.50	916.0	F16	165.0	22X25 (4 holes)	123	1557
4"	inch	3.94	17.01	8.50	8.54	7.24	9.70	10.83	1.06	1.42	12.46	36.06		6.50		271	1800
DN150	mm	150.0	559.0	278.0	282.50	214.50	320.50	355.0	36.0	48.20	385.0	916.0	F16	165.0	22X25 (4 holes)	244	3893
6"	inch	5.91	22.01	10.94	11.12	8.44	12.62	13.98	1.42	1.90	15.16	36.06		6.50		538	4500



Trunnion Mounted Ball 2 Piece

Valve Dimensions

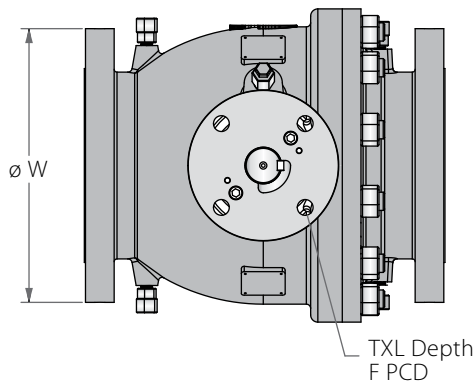
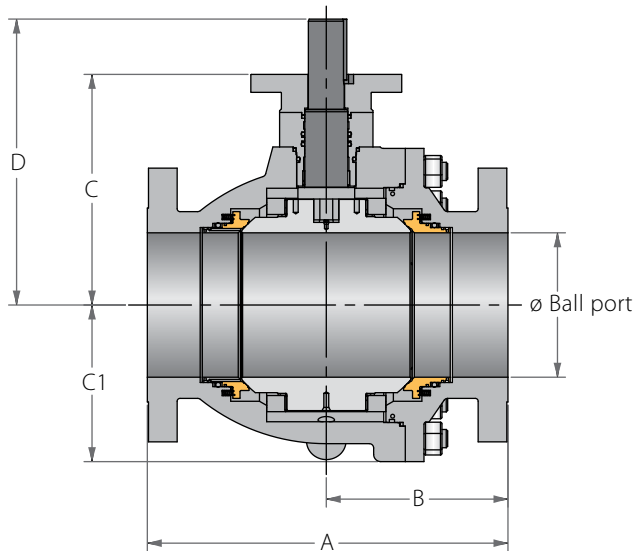

Preparation for actuation

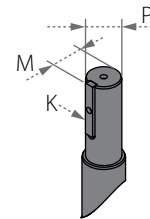

Full port	Unit	Ball port	A	B	C	C1	D	W	P	M	K	F		TxL	Weight kg/lb	Kv
																Cv
DN200	mm	201.0	660.0	330.0	312.0	263.0	409.0	420.0	72.0	76.50	20.0	F25	254.0	18x25 (8 holes)	412	7742
8"	inch	7.91	25.98	12.99	12.28	10.35	16.10	16.54	2.83	3.01	0.79		10.0			908
DN250	mm	252.0	787.0	400.0	374.0	310.0	489.50	510.0	72.0	76.50	20.0	F25	254.0	18x25 (8 holes)	665	12543
10"	inch	9.92	30.98	15.75	14.72	12.20	19.27	20.08	2.83	3.01	0.79		10.0			1466
DN300	mm	303.0	838.0	419.0	402.0	344.0	517.0	560.0	72.0	76.50	20.0	F25	254.0	18x25 (8 holes)	804	19809
12"	inch	11.93	32.99	16.50	15.83	13.54	20.35	22.05	2.83	3.01	0.79		10.0			1772
DN350	mm	334.0	889.0	444.50	435.0	412.0	565.0	605.0	80.0	87.0	22.0	F30	298.0	22x35 (8 holes)	1170	24739
14"	inch	13.15	35.0	17.50	17.13	16.22	22.24	23.82	3.15	3.43	0.87		11.73			2579

Trunnion Mounted Ball 2 Piece

Components & Materials

Item	Description	Material specification	Qty.
1	Body	Acc. Ordering Code	1
2	End	Acc. Ordering Code	1
3	Ball	Acc. Ordering Code	1
4	Stem	Acc. Ordering Code	1
5*	Seat	Acc. Ordering Code	2
5A	Seat Insert	Acc. Ordering Code	2
5B	Seat Seal	HNBR, VITON	2-4
5C	Seat Fire Safe Seal	Graphite	2
6*	Body Fire Safe Seal	Graphite	1
7*	Body Seal	HNBR, VITON	1
8	Ball Bearing	316L+PTFE	2
9	External Trunnion	A350 LF2+ENP, A479 316L, A182 F6A	1
10*	Gland Plate & External Trunnion Fire Safe Seal	Graphite	2
11*	Gland Plate & External Trunnion Seal	HNBR, VITON	2
12	Lower Thrust Washer	316L+PTFE	1
13	Seat Spring	Inconel X750	10-26
14	Gland Pin	C. Steel, S. Steel	4
15	Stem Thrust Seal	316L+PTFE	1
16	Gland Plate Bearing	316L+PTFE	1
17	Stem Seal	HNBR, VITON	2
18	Gland Plate	A350 LF2+ENP, A479 316L, A182 F6A	1
19	Stem Grease Fitting	S. Steel	1
20	Lower Gland Bolts	A320 L7, A193 B8M	2-6
21*	Stem Gasket	Graphite	1
22	Iso Plate	A350 LF2, A479 316L, A182 F6A	1
23	Upper Gland Bolts	A320 L7, A193 B8M	2-6
24	Plug Drain Valve	S. Steel	2
25**	Seat Grease Fitting + Check Valve	S. Steel	4

Item	Description	Material specification	Qty.
26	Body Stud	A320 L7, A193 B8M	4-20
27	External Trunnion Bolts	A320 L7, A193 B8M	4-12
28	Body Nut	A194 GR-7, A193 GR-8M	4-20
29	Anti-Static Spring	S. Steel	1
30	Wrench Head	S. Steel	1
31	Wrench Head Bolt	A193 B8M, EN3506-1 A4-80	1
32	Pipe Handle	C.St Zink plate, S.St	1
33	Sleeve	PVC	1

* Maintenance kit components

** Available from 6" size only

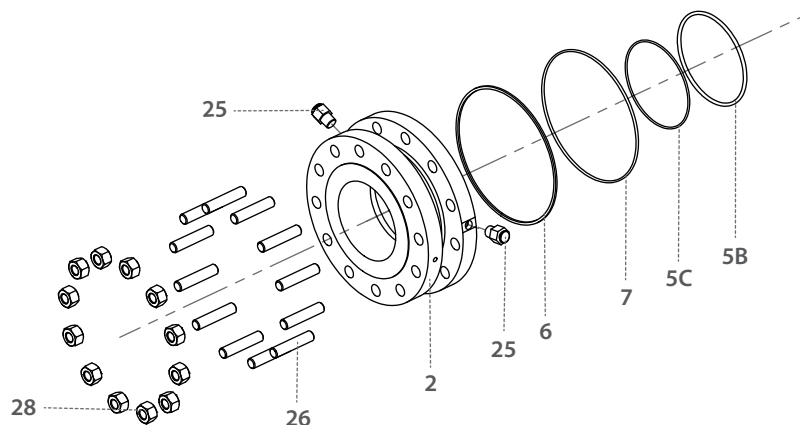



Trunnion Mounted Ball 2 Piece

Components & Materials

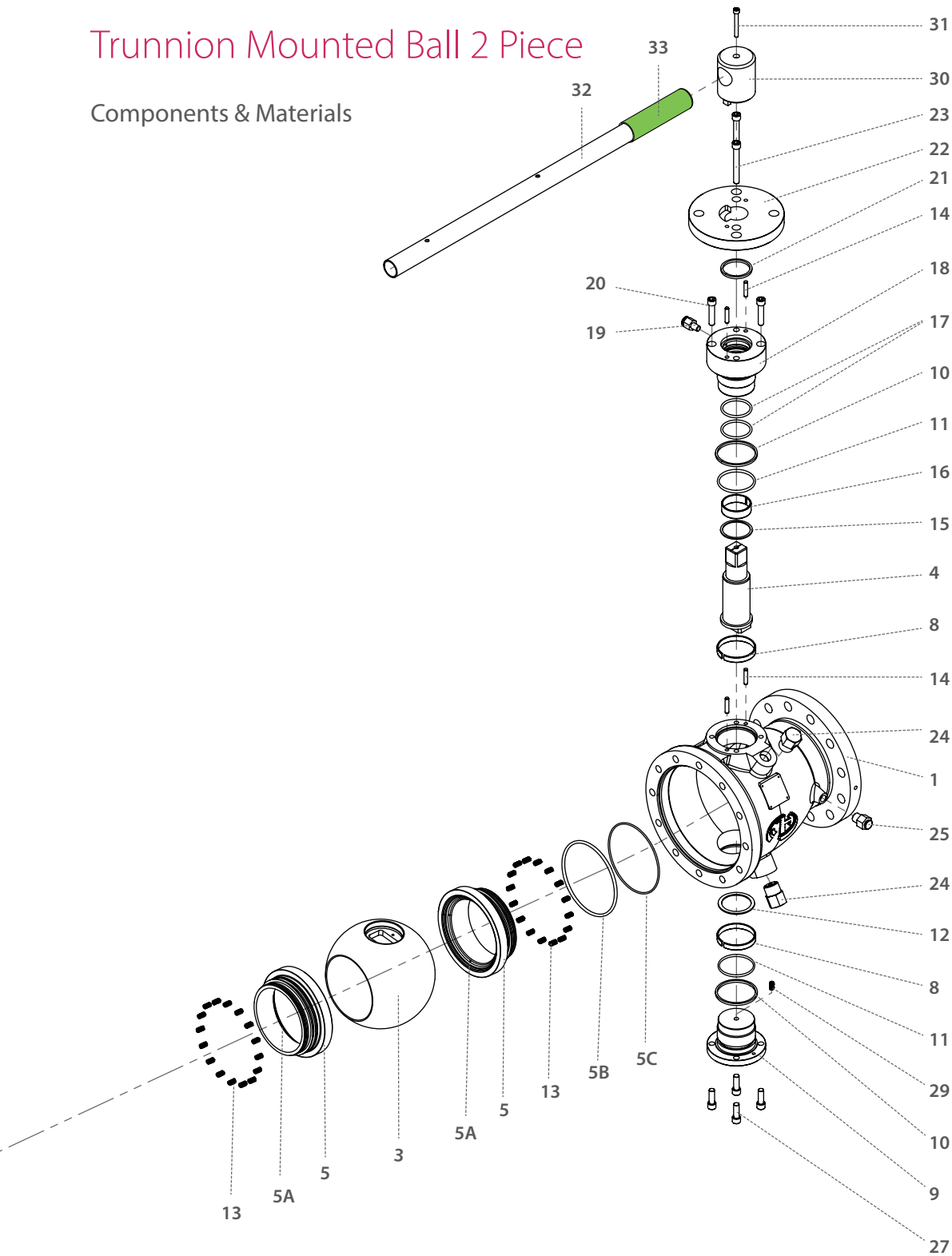

Trunnion Mounted Ball 2 Piece

Components & Materials

Item	Description	Material specification	Qty.
1	Body	Acc. Ordering code	1
2	Ends	Acc. Ordering code	1
3	Ball	Acc. Ordering code	1
4	Stem	Acc. Ordering code	1
5*	Seat	Acc. Ordering code	2
5A*	Seat Insert	Acc. Ordering code	2
5B*	Seat Seal	HNBR, VITON	2-4
5C*	Seat Fire Safe Seal	Graphite	2
6*	Body Inner Seal	HNBR, VITON	1
6A*	Body Outer Seal	Graphite	1
8*	Ball Bearing	S.steel 316 + PTFE	2
9	Trunnion Plate	S.steel / C.steel	2
10*	Gland Plate Fire Safe Seal	Graphite	1
11*	Gland Plate Seal	HNBR, VITON	1
12*	Ball Thrust Washer	S.steel 316 + PTFE	2
13	Seat Spring	Inconel X750	10-24
14	Gland Pins	S.steel / C.steel	12
15*	Stem Thrust Washer	S.steel 316 + PTFE	1
16*	Stem Bearing	S.steel 316 + PTFE	1
17*	Stem Seal	HNBR, VITON	2
18	Gland Plate	S.steel / C.steel	1
19	Stem Grease Fitting	S.steel	1
20	Lower Gland Bolts	A193-B8M / A320 L7	2-6

Item	Description	Material specification	Qty.
21*	Stem Fire Safe Seal	Graphite	1
22	ISO Plate	S.steel / C.steel	1
23	Upper Gland Bolts	A193-B8M / A320 L7	2-6
24	Plug Valve	S.steel	2
25	Seat Grease Fitting + Check Valve"	S.steel	4
26	Body Studs	A193-B8M / A320 L7	4-20
28	Body Nuts	A194-8M / A194 L7	4-20
29	Antistatic Spring	Inconel X750	1
30	Stem Key	S.steel / C.steel	1
31	Stem Key Bolt	S.steel / C.steel	1

* Maintenance kit components

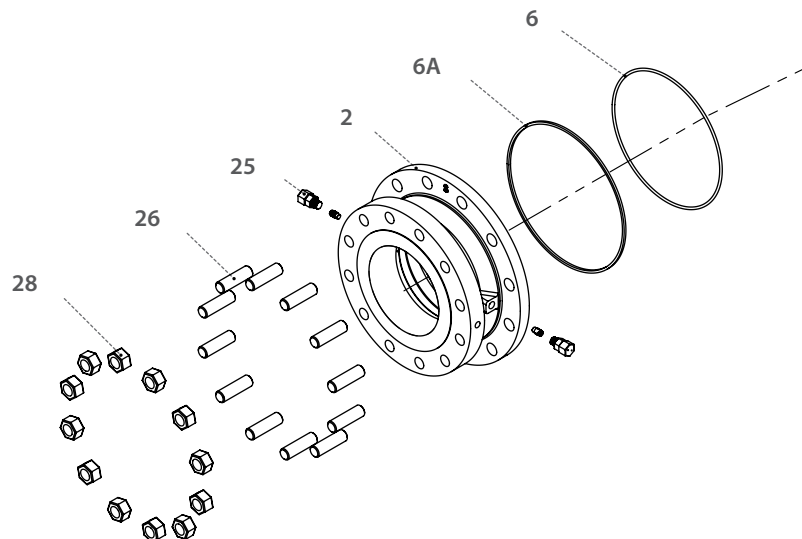

81

82

83

8"-14" | DN200-DN350
CLASS 150/300/600



Trunnion Mounted Ball 2 Piece

Components & Materials

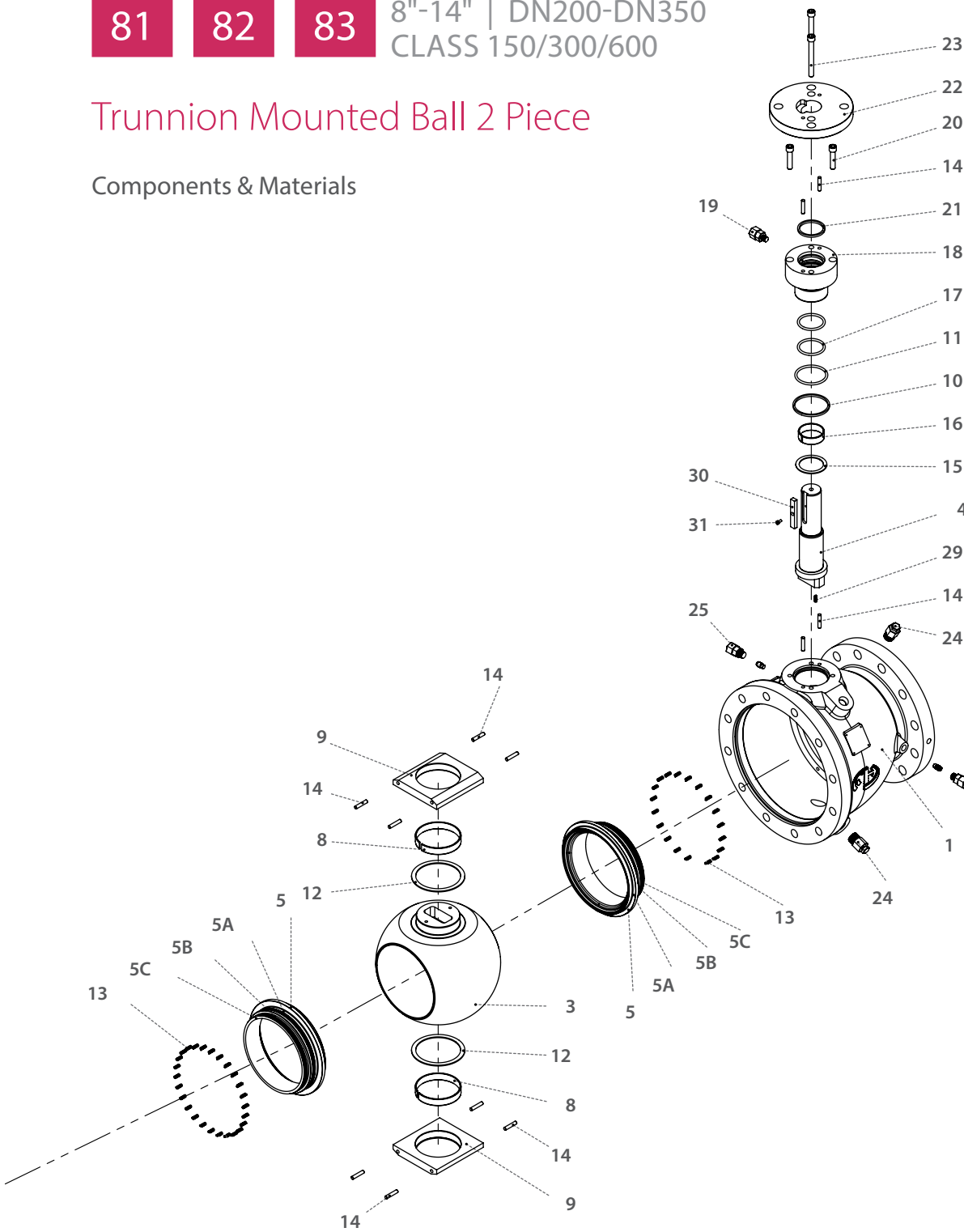



Trunnion Mounted Ball 2 Piece - Ordering Code System

"Mandatory option" options are marked with **green background** | "Standard offer" options are marked with **light green background**

1	2	3	4	5	6	7	8	9	10	11	12	13	14	15	16	17	18	19	20	21	22	23	.	.	30
6	0			F	B	8	1		-	4	6	6	D	V	V	G	/	1	5	0					
Size		Features				Series		Design		Body & ends material		Stem material	Ball material	Seat feature	Seat insert	Inner Seal material	Outer Seal material	End connection				Special features			

Size (1-2)		
Code	inch	mm
20	2"	50
30	3"	80
40	4"	100
60	6"	150
80	8"	200
A0	10"	250
A2	12"	300
A4	14"	350

Features (3-6)	
F	Fire safe
B	Full port
H*	Hydrogen Service

* for material selection - see Hydrogen Service chapter

Series - 2 Piece Cast (7-8)	
81	ASME B16.5 #150 Flanged RF
82	ASME B16.5 #300 Flanged RF
83	ASME B16.5 #600 Flanged RF

Design (9)	
Blank	(Stands for future designs)

Body & ends material (11)	
4	C. Steel A216 WCB
6	S. Steel A351 CF8M

Stem material (12)	
6 *	S. Steel A479 316\316L
Q **	S. Steel A182 F6A
M	High Strength S. Steel
Z	Inconel 718
D	Duplex
K	Super Duplex

* for 81, 82 not for 83

** for 83

Ball material (13)	
6*	S. Steel A182 F316
4	C. Steel A105+ENP
F**	C. Steel A350 LF2+ENP

* S. Steel up to 4"

** C. Steel 6" and up

Seat feature (14)	
D	Double Piston Effect (DPE) (API 6D DIB-1)
S	Single Piston Effect (SPE) (API 6D DBB)
C	DPE & SPE combination

Seat insert (15)	
V	Devlon
P	CF PTFE
K	CF PEEK

Inner Seal (16)	
V	Viton
H	HNBR

Outer Seal (17)	
G	Graphite

End Connection (19-22)		
Flanged		Series
150	ASME B16.5 #150	81
300	ASME B16.5 #300	82
600	ASME B16.5 #600	83

Special Features (23-30)	
L *	Seat greasing point
D	Drain & Vent
Blank	Greasing point, Drain & vent is capped
PT **	Basic paint system
PT1	Offshore, Temp Ambient up to 93°C (200°F)
PT2	Offshore, up to 537°C (1000°F)

* for 6" and up

** colors RAL 1018 or 7036 (other colors upon request)

In some applications the available options above are limited to specific sizes please consult with Habonim for details



FLOATING BALL

3 PIECE

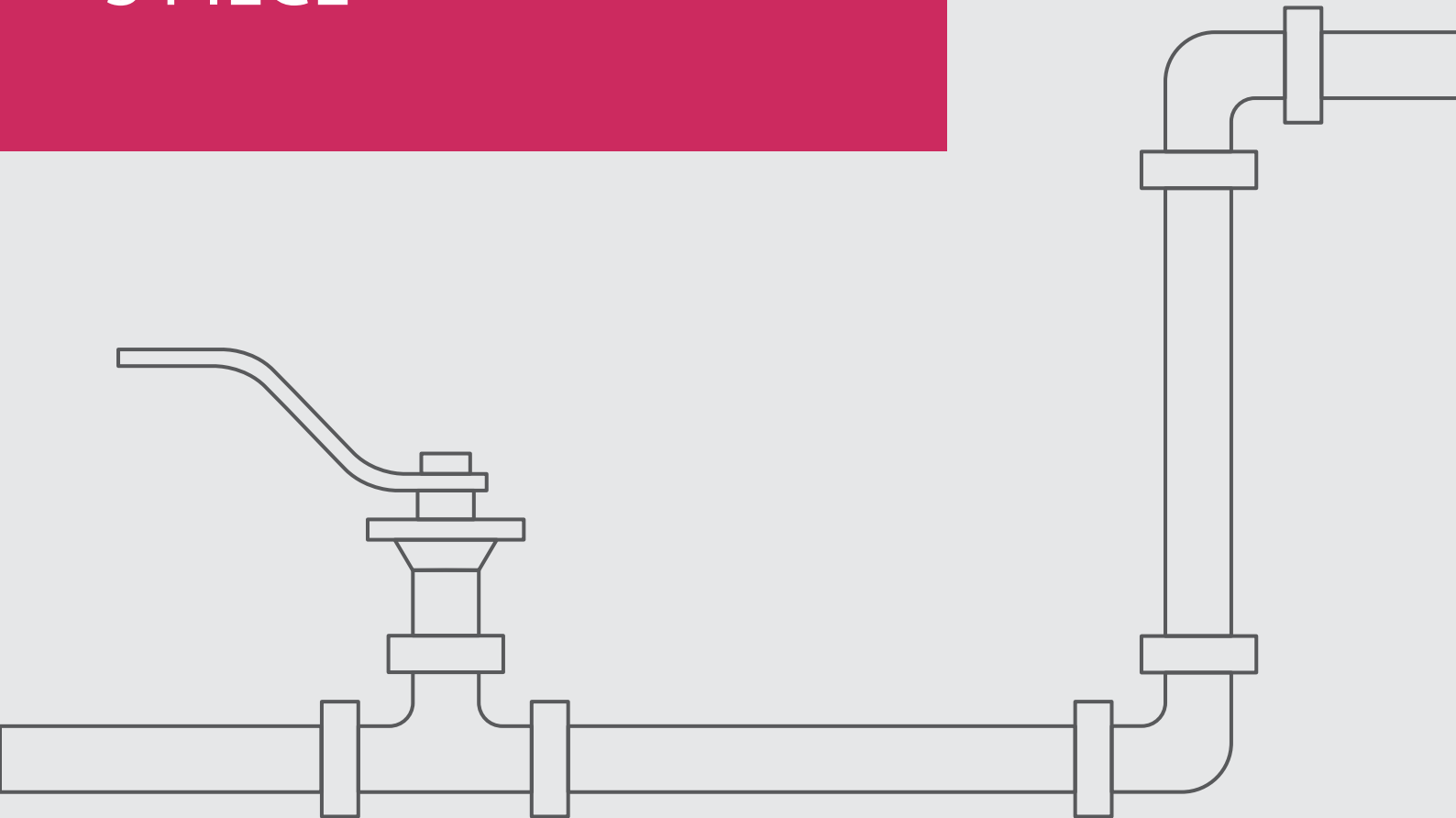

Floating Ball 3 Piece

Valve Dimensions

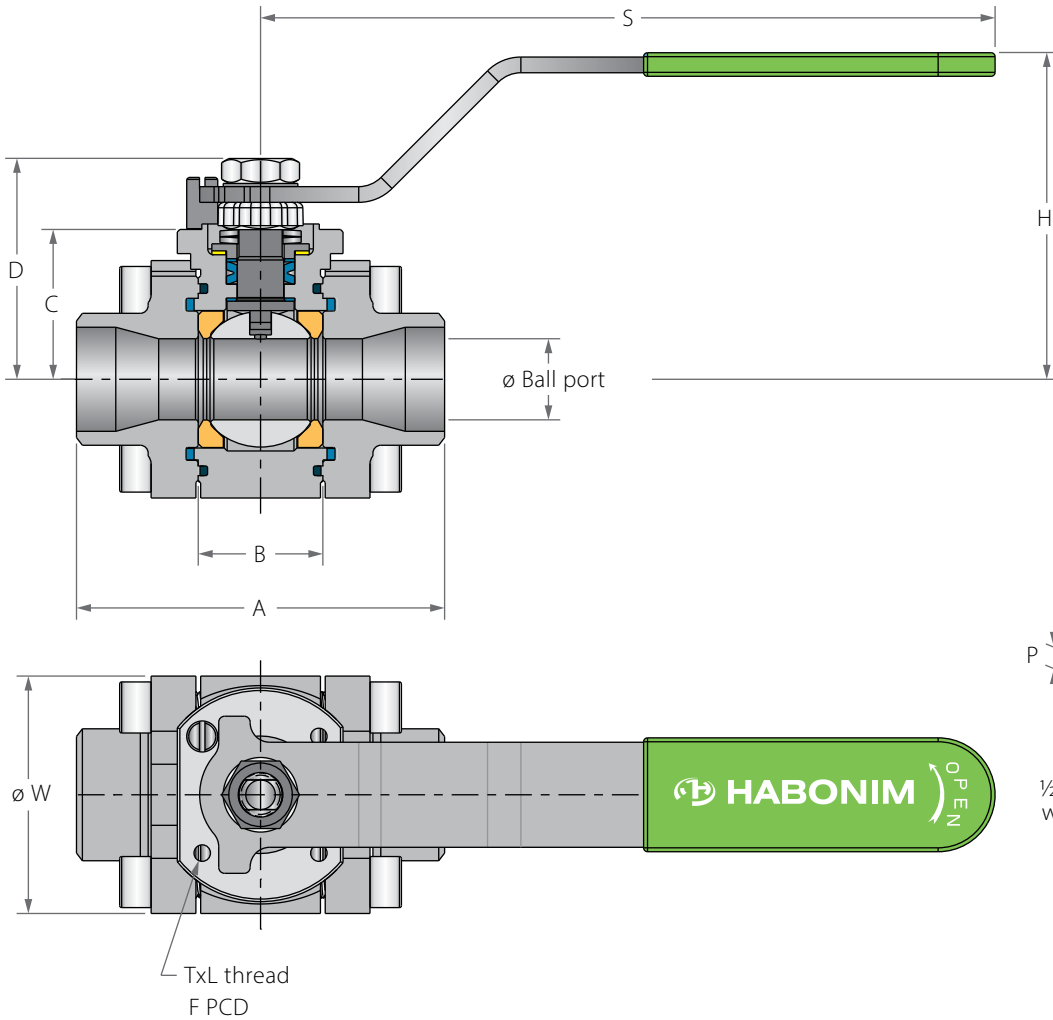

Valve Face To Face sizes are according to Habonim catalog data only, for Extended-weld/Flanged/Tri-clamp end see Face To Face sizes page.

Std. port	Full port	Unit	Ball port	A	B	C	D	H	S	W	M	N	P	F	TxL	Weight kg/lb	Kv Cv	
DN8	DN8	mm	11.15	66.0	20.60	29.0	37.90	61.50	150.0	47.0	5.54	3/8" UNF	6.65	F03	36.0	M5X10	0.60	2.6
	1/4"	inch	0.44	2.60	0.81	1.14	1.49	2.42	5.91	1.85	0.22		0.26		1.42		1.33	3.0
DN15	DN10	mm	11.15	66.0	20.60	29.0	37.90	61.50	150.0	47.0	5.54	3/8" UNF	6.65	F03	36.0	M5X10	0.60	6.9
	1/2"	3/8"	inch	0.44	2.60	0.81	1.14	1.49	2.42	5.91	1.85		0.22		0.26		1.42	1.33
DN20	DN15	mm	14.30	70.60	24.50	31.40	40.30	63.90	150.0	53.70	5.54	3/8" UNF	6.65	F03	36.0	M5X10	0.80	10
	3/4"	1/2"	inch	0.56	2.78	0.97	1.24	1.59	2.52	5.91	2.11		0.22		0.26		1.42	1.77
DN25	DN20	mm	20.60	93.70	31.70	38.10	55.60	79.40	187.0	63.70	7.54	7/16" UNF	7.40	F04	42.0	M5X10	1.60	28
	1"	3/4"	inch	0.81	3.69	1.25	1.50	2.19	3.13	7.36	2.51		0.30		0.29		1.65	3.54
DN32	DN25	mm	25.40	108.0	41.30	42.70	60.20	84.10	187.0	71.70	7.54	7/16" UNF	7.40	F04	42.0	M5X10	2.50	49
	1 1/4"	1"	inch	1.0	4.25	1.62	1.68	2.37	3.31	7.36	2.82		0.30		0.29		1.65	5.53
DN40	DN32	mm	31.80	115.50	48.40	43.60	73.0	97.0	237.0	86.70	8.71	9/16" UNF	8.50	F05	50.0	M6X12	3.60	69
	1 1/2"	1 1/4"	inch	1.25	4.55	1.91	1.72	2.87	3.82	9.33	3.41		0.34		0.33		1.97	7.96
DN50	DN40	mm	38.10	128.0	56.30	48.30	77.80	101.80	237.0	96.90	8.71	9/16" UNF	8.50	F05	50.0	M6X12	4.50	102
	2"	1 1/2"	inch	1.50	5.04	2.22	1.90	3.06	4.01	9.33	3.82		0.34		0.33		1.97	9.95



Floating Ball 3 Piece

Components & Materials

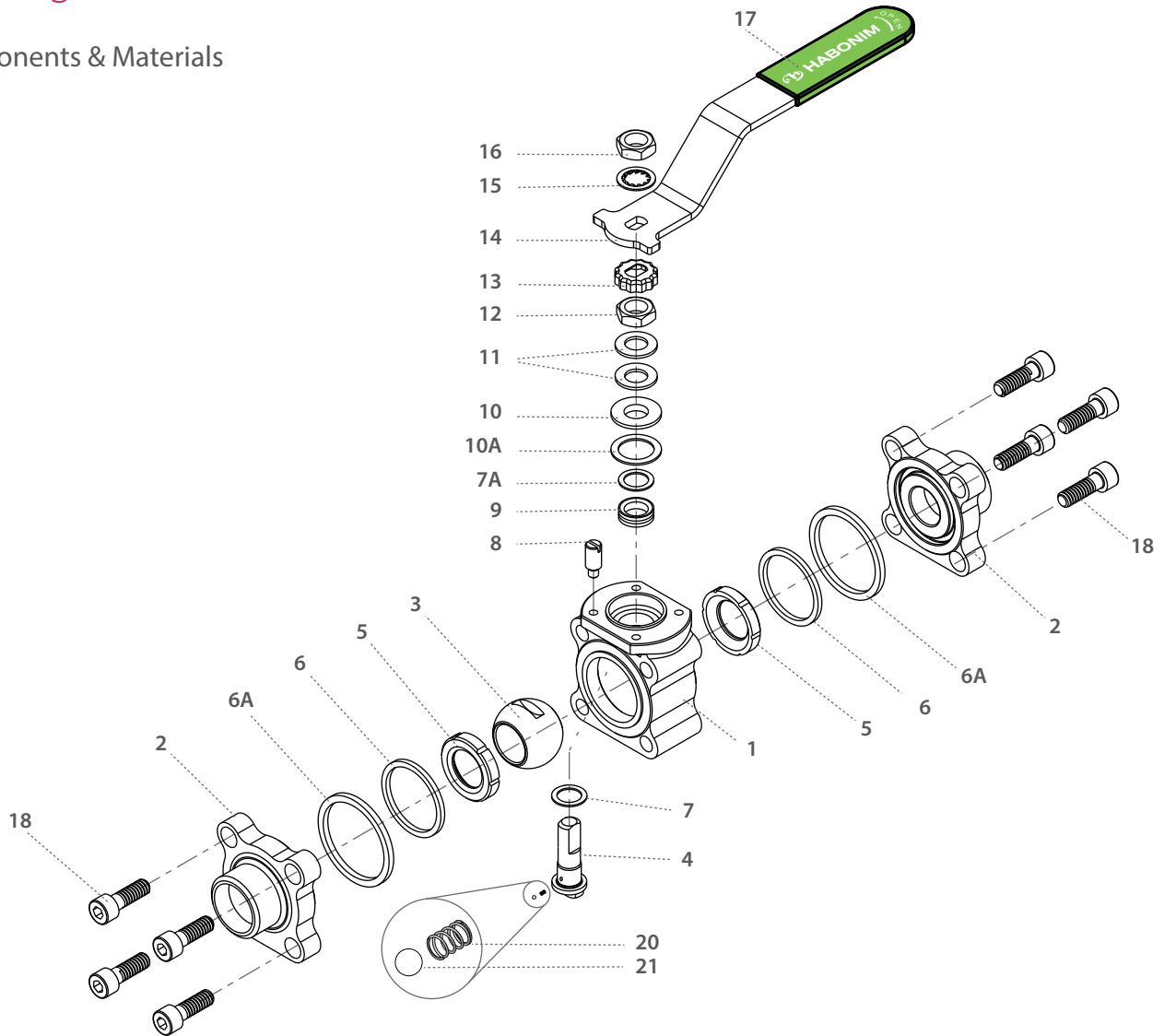

Item	Description	Material specification	Qty.
1	Body	Acc. Ordering Code	1
2	Ends	Acc. Ordering Code	2
3	Ball	Acc. Ordering Code	1
4	Stem	Acc. Ordering Code	1
5*	Seat	Acc. Ordering Code	2
6*	Inner Seal	PTFE	2
6A*	Outer Seal	Acc. Ordering Code	2
7*	Stem Thrust Seal	VIRGIN PEEK, PCTFE	1
7A*	Anti-Abrasion Ring	VIRGIN PEEK, PCTFE	1
8	Stop Pin	S. Steel	1
9*	Stem Seal	CF PTFE, TFM	1
10	Follower	S. Steel	1

Item	Description	Material specification	Qty.
10A*	Slide Bearing	S. Steel	1
11	Disc Spring	S. Steel	2
12	Stem Nut	S. Steel	1
13	Locking Clip	S. Steel	1
14	Handle	S. Steel	1
15	Serrated Washer	S. Steel	1
16	Handle Nut	S. Steel	1
17	Sleeve	PVC	1
18	Body Bolt	S. Steel	8
20	Anti-Static Spring	S. Steel	1
21	Anti-Static Plunger	S. Steel	1
23	Tag (not shown)	A167S. Steel304	1

* Maintenance kit components

Floating Ball 3 Piece

Valve Dimensions

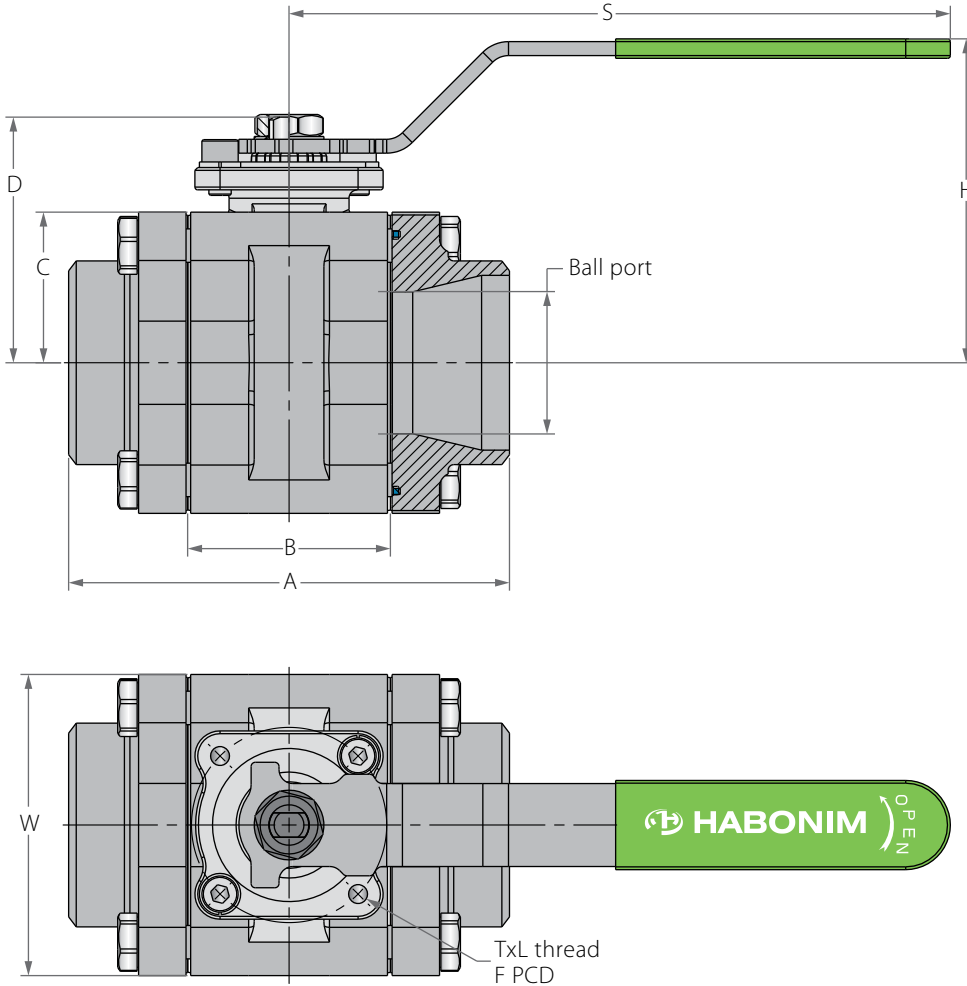

Differential pressure (Δp) is up to 70bar (1,015psi)

Preparation for actuation

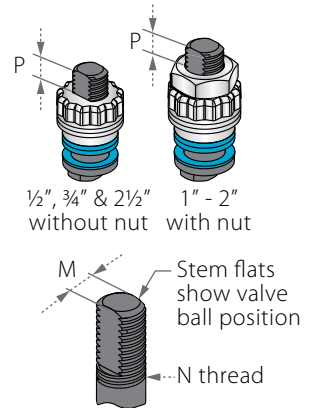

Valve Face To Face sizes are according to Habonim catalog data only, for Extended-weld/Flanged/Tri-clamp end see Face To Face sizes page.

Std. port	Full port	Unit	Ball port	A	B	C	D	H	S	W	M	N	P	F	TxL	Weight kg/lb	Kv Cv
DN65	DN50	mm	50.80	158.0	72.60	70.0	88.10	115.10	237.0	108.0	8.71	% UNF	13.50	F07	70.0	9.50	208
2½"	2"	inch	2.0	6.22	2.86	2.76	3.47	4.53	9.33	4.25	0.34		0.53		2.76	M8X12	21.00



Floating Ball 3 Piece

Components & Materials

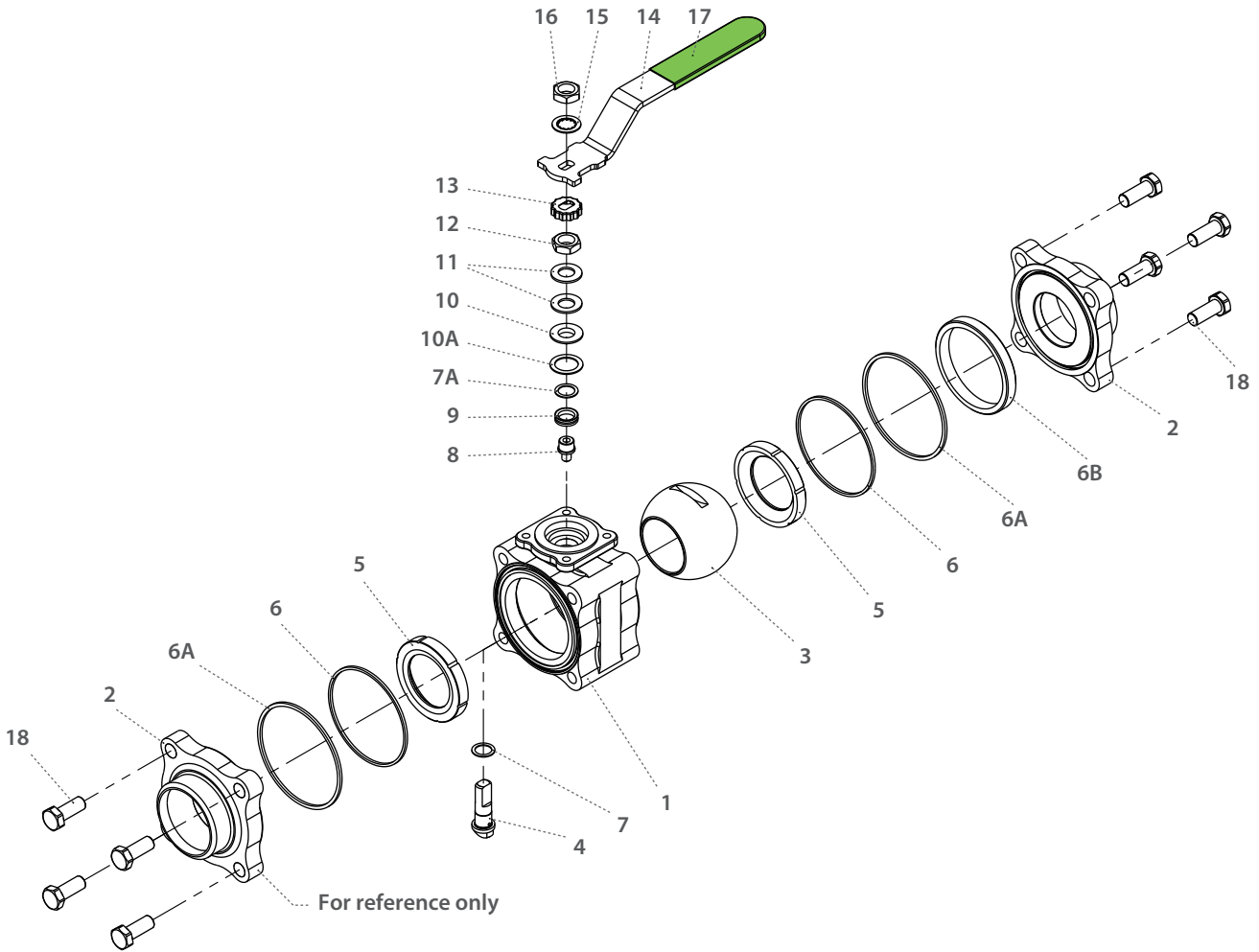

Item	Description	Material specification	Qty.
1	Body	Acc. Ordering Code	1
2	Ends	Acc. Ordering Code	2
3	Ball	Acc. Ordering Code	1
4	Stem	Acc. Ordering Code	1
5*	Seat	Acc. Ordering Code	2
6*	Inner Seal	PTFE	2
6A*	Outer Seal	Acc. Ordering Code	2
7*	Stem Thrust Seal	VIRGIN PEEK, PCTFE	1
7A*	Anti-Abrasion Ring	VIRGIN PEEK, PCTFE	1
8	Stop Pin	S. Steel	1
9*	Stem Seal	CF PTFE, TFM	1
10	Follower	S. Steel	1

Item	Description	Material specification	Qty.
10A*	Slide Bearing	S. Steel	1
11	Disc Spring	S. Steel	2
12	Stem Nut	S. Steel	1
13	Locking Clip	S. Steel	1
14	Handle	S. Steel	1
15	Serrated Washer	S. Steel	1
16	Handle Nut	S. Steel	1
17	Sleeve	PVC	1
18	Body Bolt	S. Steel	8
20	Anti-Static Spring	S. Steel	1
21	Anti-Static Plunger	S. Steel	1
23	Tag (not shown)	A167S. Steel304	1

* Maintenance kit components

Floating Ball 3 Piece

Valve Dimensions

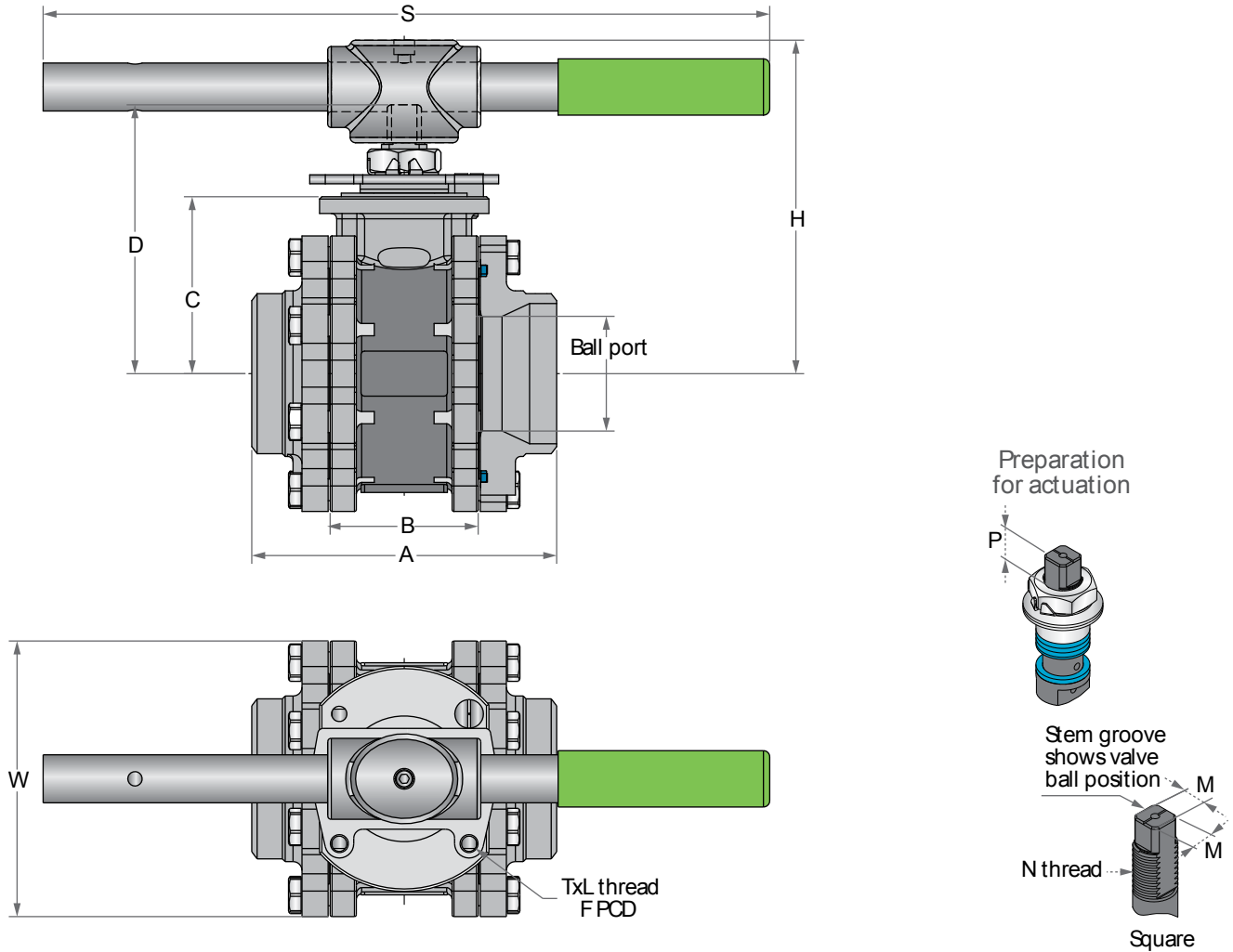

Valve Face To Face sizes are according to Habonim catalog data only, for Extended-weld/Flanged/Tri-clamp end see Face To Face sizes page.

Std. port	Full port	Unit	Ball port	A	B	C	D	H	S	W	M	M-DD	N	P	F	TxL	Weight kg/lb	Kv Cv	
DN80	DN65	mm	63.50	169.0	83.30	98.30	144.90	185.0	400.0	140.0	18.90	15.90	1"-14	16.70	F10	102.0	M10x20	13.70	300
3"	2½"	inch	2.50	6.65	3.28	3.87	5.71	7.29	15.75	5.50	0.74	0.63	UNS-2A	0.66		4.02		30.30	348
DN100	DN80	mm	82.60	214.0	108.80	114.10	160.70	200.0	600.0	177.0	18.90	15.90	1"-14	16.70	F10	102.0	M10x20	23.70	615
4"	3"	inch	3.25	8.43	4.28	4.49	6.33	7.89	23.62	6.97	0.74	0.63	UNS-2A	0.66		4.02		52.40	713
	DN100	mm	100.0	239.0	123.0	124.0	170.50	211.0	600.0	217.0	18.90	15.90	1"-14	16.70	F10	102.0	M10x20	30.00	744
	4"	inch	3.94	9.41	4.84	4.88	6.71	8.30	23.62	8.54	0.74	0.63	UNS-2A	0.66		4.02		66.30	863
DN150		mm	111.10	346.0	146.0	157.0	226.0	286.0	916.0	266.0	28.45	23.75	1½"-12	26.20	F12	125.0	M12x20	63.00	872
6"		inch	4.37	13.62	5.75	6.18	8.90	11.26	36.06	10.47	1.12	0.94	UNF-2A	1.03		4.92		138.90	1012



Floating Ball 3 Piece

Components & Materials

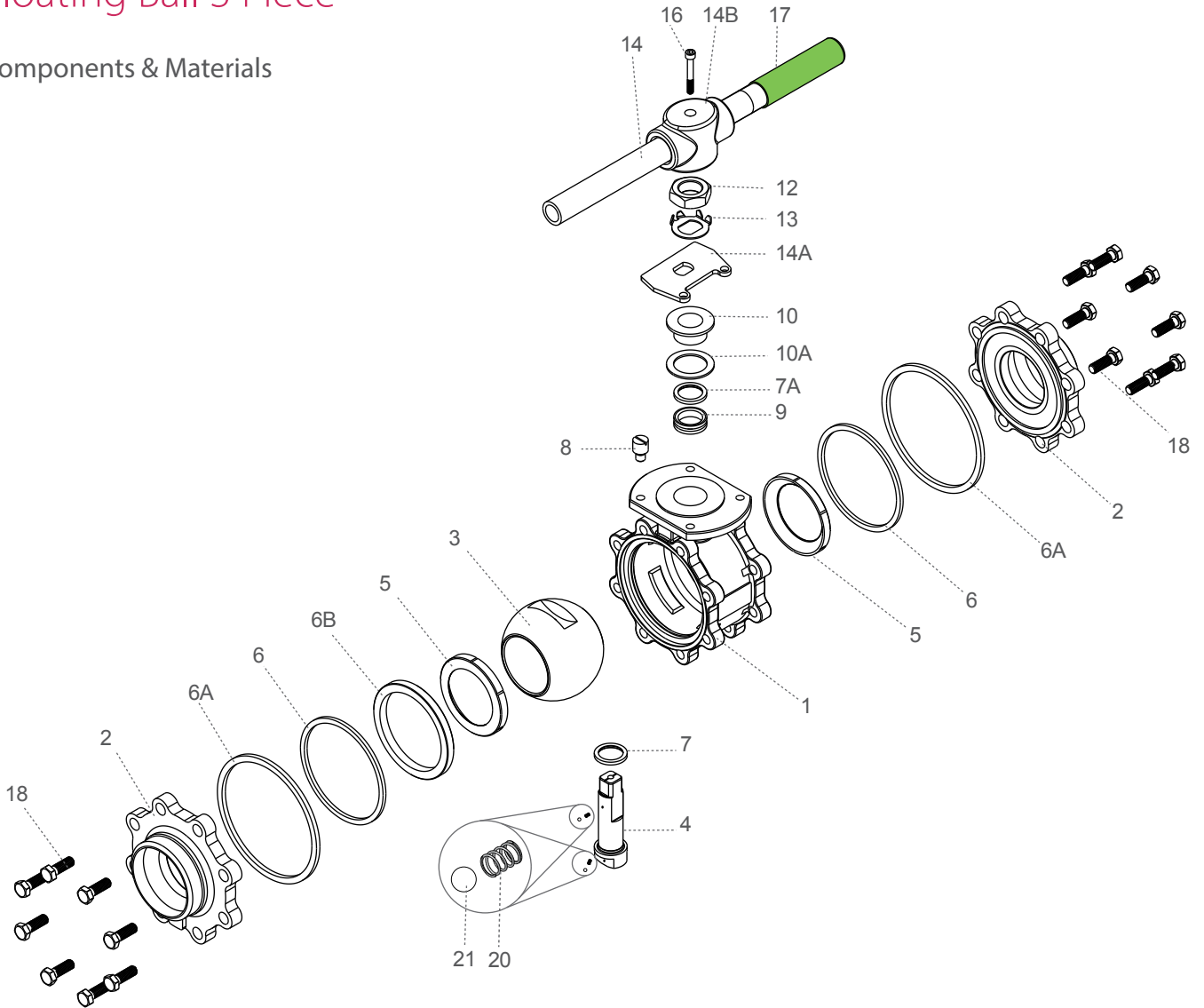

Item	Description	Material specification	Qty.
1	Body	Acc. Ordering Code	1
2	Ends	Acc. Ordering Code	2
3	Ball	Acc. Ordering Code	1
4	Stem	Acc. Ordering Code	1
5*	Seat	Acc. Ordering Code	2
6*	Inner Seal	PTFE	2
6A*	Outer Seal	Acc. Ordering Code	2
6B	Support Ring	S. Steel	1
7*	Stem Thrust Seal	VIRGIN PEEK, PCTFE (KEL-F)	1
7A*	Anti-Abrasion Ring	VIRGIN PEEK, PCTFE (KEL-F)	1
8	Stop Pin	S. Steel	1
9*	Stem Seal	CF PTFE, TFM	1
10	Follower	S. Steel	1
10A*	Slide Bearing	S. Steel	1

Item	Description	Material specification	Qty.
11	Disc Spring	S. Steel	2
12	Stem Nut	S. Steel	1
13	Tab Lock Washer	S. Steel	1
14	Handle	C. Steel	1
14A	Stop Plate	S. Steel	1
14B	Wrench Head	S. Steel	1
16	Wrench Bolt	S. Steel	1
17	Sleeve	PVC	1
18	Body Bolts	S. Steel	16-24
20	Anti-Static Spring	S. Steel	2
21	Anti-Static Plunger	S. Steel	2
23	Tag (not shown)	S. Steel	1

* Maintenance kit components

Face To Face Sizes

Valve Size	Unit	B		A-XBW / ETI / ETD / GR		A-ETO	A-TC	A-Flange Class 150+300		A-Flange Class 600		A-Flanged DIN PN16-PN100	
		Std. port	Full port	Std. port	Full port	Std. port	Std. port	Std. port	Full port	Std. port	Full port	Std. port	Full port
DN8	mm	20.6	----	140.6	----	104.6	----	----	----	----	----	----	----
¼"	inch	0.8	----	5.54	----	4.12	----	----	----	----	----	----	----
DN10	mm	20.6	----	140.6	----	137.0	----	----	----	----	----	130.0	----
⅜"	inch	0.8	----	5.54	----	5.39	----	----	----	----	----	5.12	----
DN15	mm	20.6	24.5	140.6	146.9	137.0	89.0	140.0	139.9	165.0	152.0	130.0	130.0
½"	inch	0.8	1.0	5.54	5.78	5.39	3.5	5.51	5.51	6.5	6.0	5.12	5.11
DN20	mm	24.5	31.7	146.9	168.7	146.9	101.5	152	152.3	151.9	165.1	150.0	150.0
¾"	inch	1.0	1.25	5.8	6.64	5.78	4.0	6.0	6.0	5.98	6.5	5.9	5.91
DN25	mm	31.7	41.3	168.7	179.3	164.0	114.3	165.0	164.9	215.9	178.0	160.0	160.0
1"	inch	1.25	1.63	6.64	7.06	6.46	4.5	6.49	6.49	8.5	7.01	6.3	6.3
DN32	mm	41.3	48.4	179.3	189.4	179.3	----	178.0	178.0	178.0	178.0	180.1	180.0
1¼"	inch	1.6	1.9	7.06	7.46	7.06	----	7.0	7.0	7.0	7.0	7.1	7.1
DN40	mm	48.4	56.3	189.4	200.3	184.0	140.0	190.0	190.5	241.4	216.1	200.0	200.0
1½"	inch	1.91	2.22	7.46	7.9	7.24	5.5	7.5	7.5	9.5	8.51	7.9	7.9
DN50	mm	56.3	72.6	200.3	232.6	193.5	159.0	216.0	216	292.1	241.0	229.9	230.0
2"	inch	2.22	2.86	7.89	9.16	7.62	6.3	8.5	8.5	11.5	9.5	9.05	9.06
DN65	mm	72.6	83.3	232.6	283.3	232.6	213.0	241.0	241.0	241.0	330.0	230.0	270.0
2½"	inch	2.9	3.28	9.16	11.15	9.16	8.4	9.5	11.1	9.5	13.0	9.06	10.63
DN80	mm	83.3	108.8	283.3	349.0	283.3	215.8	282.0	282.2	356.0	356.0	279.9	310.0
3"	inch	3.28	4.28	11.15	13.7	11.15	8.5	11.1	11.1	14.0	14.0	11.0	12.2
DN100	mm	109.0	123.0	349.0	390.0	349.0	245.4	305.0	305	432.0	432.0	350.0	350.0
4"	inch	4.28	4.84	13.7	15.4	13.7	9.7	12.0	12.0	17.0	17.0	13.8	13.8
DN150	mm	146.0	----	444.0	420.0	444.0	146.1	403.1	403.1	559.0	559.0	350.0	480.0
6"	inch	5.75	----	17.5	16.5	17.5	5.8	15.9	15.9	22.0	22.0	13.8	18.9

XBW / ETO / ETI / ETD / GR

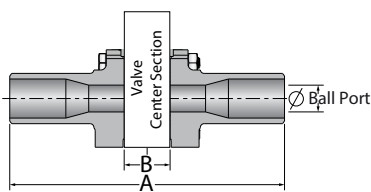

Flanged

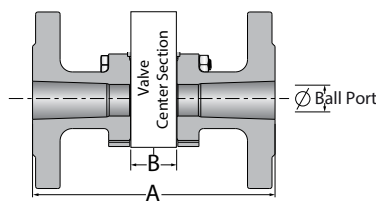

TC

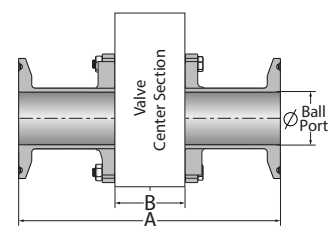
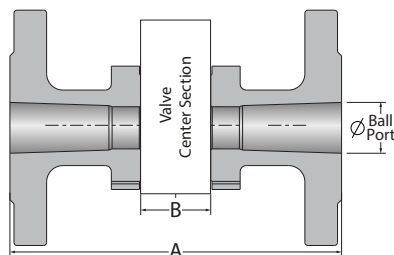
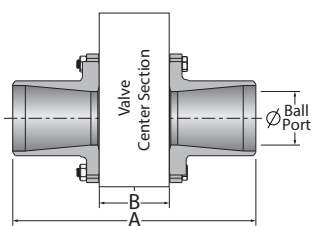
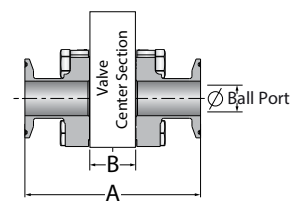



ASME BPE Floating Ball 3 Piece

Valve Dimensions - DIN 11850 sizes

DIN 11850 sizes	Unit	Full port	OD	ID	A ETD	A TCD	B	C	D	H	K	S	W	RTCD	M	N	P	F1	F2	TxL	Weight kg/lb	Kv Cv
DN10	mm	11.15	13.0	10.0	100.0	90.0	20.60	29.0	11.15	46.30	41.50	115.0	69.0	34.0	5.54	3/8"	7.20	-	32.0	M5X6	1.00	9
3/8"	Inch	0.44	0.51	0.39	3.94	3.54	0.81	1.14	0.44	1.82	11.63	4.53	2.72	1.34	0.22	UNF	0.28	-	1.26	M5X6	2.20	10
DN15	mm	14.3	19.0	16.0	110.0	95.0	24.60	36.0	14.3	49.40	44.0	115.0	69.0	34.0	5.54	3/8"	7.20	15.0	34.0	M5X6	1.30	30
1/2"	Inch	0.56	0.75	0.63	4.33	3.74	0.97	1.42	0.56	1.94	1.73	4.53	2.72	1.34	0.22	UNF	0.28	0.59	1.34	M5X6	2.85	35
DN20	mm	20.6	23.0	20.0	120.0	110.0	31.70	36.0	20.6	61.0	44.0	146.0	79.0	34.0	5.54	3/8"	7.20	20.0	36.0	M5X8	2.20	48
3/4"	Inch	0.81	0.91	0.79	4.72	4.33	1.25	1.42	0.81	2.40	1.73	5.75	3.11	1.34	0.22	UNF	0.28	0.79	1.42	M5X8	4.85	56
DN25	mm	25.4	29.0	26.0	180.0	130.0	41.30	43.50	25.4	85.0	44.0	187.0	94.0	50.50	7.54	7/16"	7.20	29.70	29.70	M5X8	2.80	97
1"	Inch	1.0	1.14	1.02	7.09	5.12	1.63	1.71	1.0	3.35	1.73	7.36	3.70	1.99	0.30	UNF	0.28	1.17	1.17	M5X8	6.20	114
DN32	mm	31.8	35.0	32.0	190.0	140.0	48.40	55.50	31.8	99.0	46.0	237.0	99.0	50.50	7.54	7/16"	8.0	35.35	35.35	M6X10	4.40	145
1 1/4"	Inch	1.25	1.38	1.26	7.48	5.51	1.91	2.19	1.25	3.90	1.73	9.33	3.90	1.99	0.30	UNF	0.31	1.39	1.39	M6X10	9.70	170
DN40	mm	38.1	41.0	38.0	200.0	150.0	56.30	48.25	38.1	103.0	46.0	237.0	109.0	50.50	8.71	9/16"	8.0	35.35	35.35	M6X10	8.00	168
1 1/2"	Inch	1.50	1.61	1.50	7.87	5.91	2.22	1.90	1.50	4.06	1.73	9.33	4.29	1.99	0.34	UNF	0.31	1.39	1.39	M6X10	17.60	196

DIN 11850 sizes	Unit	Full port	OD	ID	A ETD	A TCD	B	C	D	H	K	S	W	RTCD	M	M-DD	N	P	F1	F2	TxL	Weight kg/lb	Kv Cv
DN50	mm	50.8	53.0	50.0	100.0	90.0	72.70	70.0	50.8	129.30	45.0	401.0	139.0	64.0	-	13.90	M20X2.5	14.60	70.0	49.50	M8X12	12.0	385
2"	Inch	2.0	2.09	1.97	3.94	3.54	2.86	2.76	2.0	5.09	1.77	15.79	5.47	2.52	-	0.57	M20X2.5	0.57	2.76	1.95	M8X12	25.0	450
DN65	mm	63.5	70.0	66.0	110.0	95.0	83.40	98.30	63.5	169.20	57.20	401.0	164.0	91.0	18.90	15.90	1"-14	16.70	102.0	100.0	M10X20	19.0	581
2 1/2"	Inch	2.50	2.76	2.60	4.33	3.74	3.28	3.87	2.50	6.66	2.25	15.79	6.46	3.58	0.74	0.63	UNS-2A	0.66	4.02	3.94	M10X20	41.0	680
DN80	mm	82.6	85.0	81.0	120.0	110.0	112.0	105.50	82.6	184.50	70.0	401.0	199.0	106.0	18.90	15.90	1"-14	16.70	102.0	120.0	M10X20	30.0	1060
3"	Inch	3.25	3.35	3.19	4.72	4.33	4.41	4.15	3.25	7.26	2.75	15.79	7.83	4.17	0.74	0.63	UNS-2A	0.66	4.02	4.72	M10X20	66.0	1240
DN100	mm	100.0	104.0	100.0	180.0	130.0	123.0	179.0	100.0	193.50	61.0	401.0	224.0	119.0	18.90	15.90	1"-14	16.70	102.0	140.0	M10X20	40.0	1402
4"	Inch	3.94	4.09	3.94	7.09	5.12	4.84	7.05	3.94	7.62	2.40	15.79	8.82	4.69	0.74	0.63	UNS-2A	0.66	4.02	5.51	M10X20	88.0	1640

ASME BPE Floating Ball 3 Piece

Valve Dimensions - ISO 1127 sizes

ISO 1127 sizes	Unit	Full port	OD	ID	A ETD	A TCD	B	C	D	H	K	S	W	R TCD	M	N	P	F		TxL	Weight kg/lb	Kv Cv
DN10	mm	11.15	17.20	14.0	147.0	89.0	24.60	35.30	11.15	67.90	47.0	150.0	54.0	25.0	5.54	3/8"	6.50	F03	36.0	M5X6	1.00	9
3/8"	Inch	0.44	0.68	0.55	5.79	3.50	0.97	1.39	0.44	2.67	1.85	5.91	2.13	0.98	0.22	UNF	0.26		1.42		2.20	10
DN15	mm	14.3	21.30	18.10	164.0	118.0	31.70	38.20	14.3	86.0	49.0	187.0	61.0	50.50	7.50	7/16"	5.50	F04	42.0	M5X10	1.75	30
1/2"	Inch	0.56	0.84	0.71	6.46	4.65	1.25	1.50	0.56	3.39	1.93	7.36	2.40	1.99	0.30	UNF	0.22		1.65		3.85	35
DN20	mm	20.6	26.90	23.70	168.0	118.0	35.50	43.50	20.6	89.0	49.0	187.0	61.0	50.50	7.50	7/16"	7.20	F04	42.0	M5X10	2.00	48
3/4"	Inch	0.81	1.06	0.90	6.61	4.65	1.40	1.71	0.81	3.50	1.93	7.36	2.40	1.99	0.30	UNF	0.28		1.65		4.40	56
DN25	mm	25.4	33.70	29.70	186.0	141.0	50.0	51.50	25.4	105.0	49.0	236.0	80.0	50.50	8.67	9/16"	8.0	F05	50.0	M6X12	4.00	98
1"	Inch	1.0	1.33	1.17	7.32	5.55	1.97	2.03	1.0	4.13	1.93	9.29	3.15	1.99	0.34	UNF	0.31		1.97		8.80	114
DN32	mm	31.8	42.40	38.40	200.0	-	56.30	48.20	31.8	100.0	49.0	236.0	91.0	64.0	8.67	9/16"	8.0	F05	50.0	M6X12	5.00	145
1 1/4"	Inch	1.25	1.67	1.51	7.87	-	2.22	1.90	1.25	3.94	1.93	9.29	3.58	2.52	0.34	UNF	0.31		1.97		11.00	170

ISO 1127 sizes	Unit	Full port	OD	ID	A ETD	A TCD	B	C	D	H	K	S	W	R TCD	M	M-DD	Q	N	P	F		TxL	Weight kg/lb	Kv Cv
DN40	mm	38.1	48.30	44.30	223.0	184.0	72.70	70.0	38.1	143.10	45.0	401.0	108.0	64.0	-	13.90	20.0	M20	14.0	F07	70.0	M8X10	9.50	168
1 1/2"	inch	1.50	1.90	1.74	8.78	7.24	2.86	2.76	1.50	5.63	1.77	15.79	4.25	2.52	-	0.55	0.79		0.55		2.76		20.90	196
DN50	mm	50.8	60.30	56.30	250.40	169.10	83.35	98.30	50.8	185.10	57.20	401.0	139.70	77.50	18.90	15.90	22.70	1"-14	16.70	F10	102.0	M10X12	14.00	385
2"	inch	2.0	2.37	2.22	9.86	6.66	3.28	3.87	2.0	7.29	2.25	15.79	5.50	3.05	0.74	0.63	0.89	UNF-2A	0.66		4.02		30.80	450
DN65	mm	63.5	76.10	72.10	302.0	193.0	96.40	105.50	63.5	192.40	70.0	401.0	160.0	91.0	18.90	15.90	22.70	1"-14	16.70	F10	102.0	M10X12	17.70	581
2 1/2"	Inch	2.50	3.0	2.84	11.89	7.60	3.80	4.15	2.50	7.57	2.76	1.58	6.30	3.58	0.74	0.63	0.89	UNF-2A	0.66		4.02		38.94	680
DN80	mm	82.6	88.90	84.30	349.0	236.0	108.80	114.10	82.6	200.0	80.0	600.0	177.0	106.0	18.90	15.90	22.70	1"-14	16.70	F10	102.0	M10X12	26.00	106
3"	Inch	3.25	3.50	3.32	13.74	9.29	4.28	4.49	3.25	7.87	3.15	23.62	6.97	4.17	0.74	0.63	0.89	UNF-2A	0.66		4.02		57.20	1240

Standard	Sizes	Wall thickness (mm)	End Connection (19-22)	End Connection Length
ISO 1127	3/8"-3/4"	1.6	BW1.6	Short
			ET1.6	Extended
	1"-2 1/2"	2.0	BW2.0	Short
			ET2.0	Extended
	Over 2 1/2"	2.3	BW2.3	Short
			ET2.3	Extended



Floating Ball 3 Piece - Ordering Code System

"Mandatory option" options are marked with **green background** | "Standard offer" options are marked with **light green background**

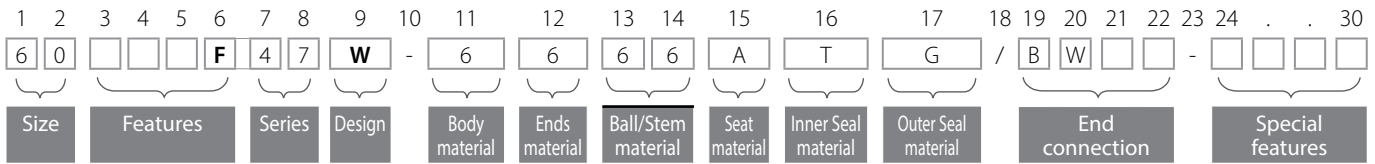

Size (1-2)		
Code	inch	mm
02	¼"	8
03	⅜"	10
05	½"	15
07	¾"	20
10	1"	25
12	1¼"	32
15	1½"	40
20	2"	50
25	2½"	65
30	3"	80
40	4"	100
60	6"	150

Features (3-6)	
F	Fire safe
B	Full port
Q	Cavity filler seats

Series (7-8)	
47	Floating ball 3 piece

Design (9)	
W	Total HermetiX Integrity package
G	Total HermetiX Integrity package - FDA compliant

Body material (11)	
6	S. SteelCF8M
4	C. steel
W	Hastelloy-C22
S	254SMO
D	Duplex
9	Low Temp C. steel
1	Bronze
K	Super Duplex
7	Monel
A	Alloy-20
C	Hastelloy-C276

Ends material (12)	
6	S. SteelCF8M/CF3M*
4	C. steel
W	Hastelloy-C22
S	254SMO
D	Duplex
9	Low Temp C. steel
1	Bronze
K	Super Duplex
7	Monel
A	Alloy-20
C	Hastelloy-C276

* CF3M - welded end connection only.

Ball material (13)	
6	S. SteelCF8M/316
W	Hastelloy-C22
S	254SMO
D	Duplex
1	Bronze
K	Super Duplex
7	Monel
A	Alloy-20
C	Hastelloy-C276

Stem material (14)	
6	S. Steel316
M	High Strength S. Steel
Z	Inconel 718
W	Alloy-C22
S	254SMO A479
A	Alloy-20
D	Duplex A479
K	Super Duplex A479
7	Monel
C	Hastelloy-C276

Seat material (15)	
A	TFM
P	CF PTFE
K	CF PEEK
L	Virgin Peek
U	UHMWPE
C	PCTFE
Y	Delrin
W	PVDF
T	PTFE
R	15% Glass filled PTFE

Inner Seal Material (16)	
T	PTFE
G	Expanded graphite
U	UHMWPE
V	Viton
B	NBR

Outer Seal Material (17)	
G	Expanded graphite
A	TFM
U	UHMWPE

End Connection (19-22)	
Welded	
BW10	Buttweld schd. 10
BW	Buttweld schd. 40
SW	Socket weld
XBW10	Extended buttweld schd. 10
XBW	Extended buttweld schd. 40
XSW	Extended socket weld
BW5	Buttweld schd. 5
BW80	Buttweld schd. 80
BWO*	Buttweld tube OD
BWD	Buttweld DIN 11850
BW1.6	Buttweld ISO 1127 1.6mm
BW12.0	Buttweld ISO 1127 2.0mm
BW12.3	Buttweld ISO 1127 2.3mm
SWO*	Socket weld tube OD
ETO*	Extended tube OD
ET1.6	Extended buttweld ISO 1127 1.6mm
ET12.0	Extended buttweld ISO 1127 2.0mm
ET12.3	Extended buttweld ISO 1127 2.3mm
ETD	Extended buttweld DIN 11850

Threaded	
NPT	ASME B1.20.1 - National Pipe Taper thread
BSPT	EN 10226 - Pipe Taper thread
BSPP	ISO228-1, DIN3852 - Pipe Parallel thread
DIN3852	DIN3852 - Pipe Parallel thread
AS5202	SAE internal straight thread
MNPT	Male NPT
MBSPT	Male BSPT

Flanged	
150	ASME B16.5 #150 RF
300	ASME B16.5 #300 RF
600	ASME B16.5 #600 RF
900	ASME B16.5 #900 RF
PN16	EN1092 PN16 RF
PN40	EN1092 PN40 RF
PN63	EN1092 PN63 RF
PN100	EN1092 PN100 RF
PN160	EN1092 PN160 RF

Clamp	
LL*	Compression fitting (Imperial) - No Nuts & Ferrules
LM*	Compression fitting (metric) - No Nuts & Ferrules
LL-NF*	Compression fitting (Imperial) - with Nuts & Ferrules
LM-NF*	Compression fitting (metric) - with Nuts & Ferrules
TC*	Tri-Clamp
GR**	Grayloc© compatible hub (Grayloc© is a registered trademark of Grayloc Products, L.L.C.)

* Std. port Only

** Not available for 1¼" (DN32) Valves

Special Features (24-30)	
P250	Ball with Upstream Relief Hole
SRS	Self Relief Seat
B	Body made from barstock
EP	Electropolished
J2N05	Jacketed valve - number of ports (2), type (NPT) and size (½")
Valve Special Stem Seals	
LAX	FDA Compliant, Stem seal, Virgin Peek thrust and TFM, X shape, gasket
HC	High Cycle service

Floating Ball 3 Piece

Valve Dimensions

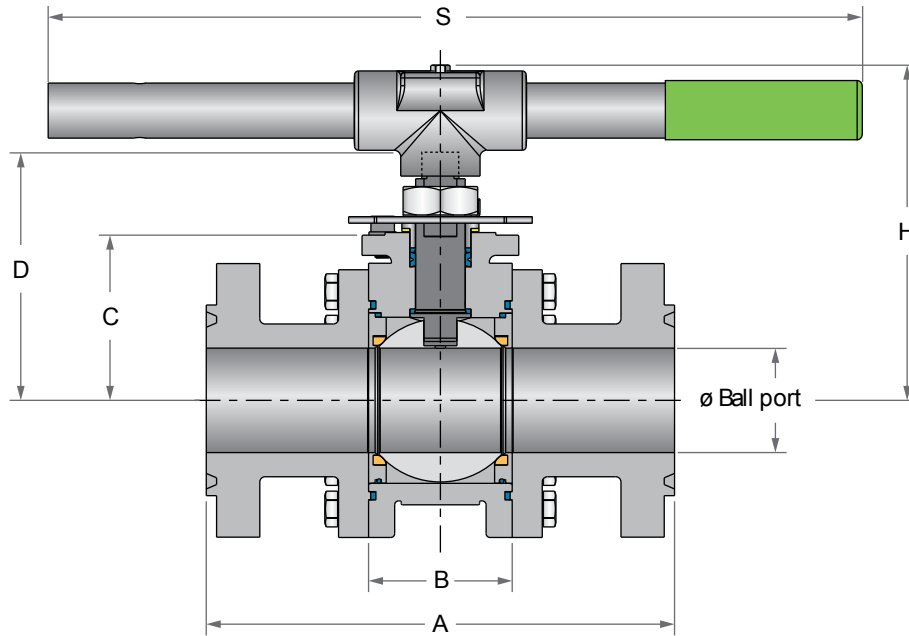

Optional hybrid seat U-shape

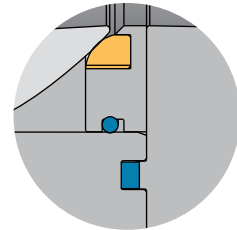

Preparation for actuation

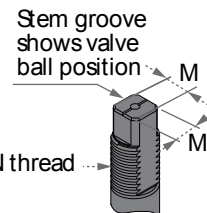
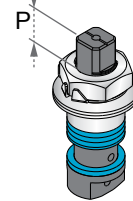

Square

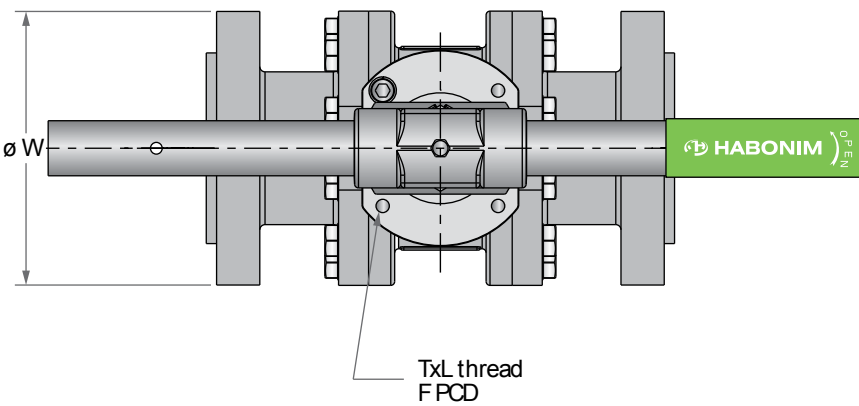

Std. port	Unit	Ball port	A (RF)	A (RTJ)	B	C	D	H	S	W	M	M-DD	N	P	Q	F	TxL	Weight kg/lb	Kv Cv	
DN50	mm	51.0	292.10	292.15	75.0	87.50	134.0	174.45	401.0	165.10	18.90	15.90	1"-14	16.70	22.70	F10	102.0	M10x12	14.20	430
2"	inch	2.01	11.50	11.62	2.95	3.44	5.28	6.87	15.79	6.50	0.74	0.63	UNS-2A	0.66	0.89		4.02		31.30	499
DN80	mm	80.0	355.60	358.65	110.0	126.50	195.90	256.60	916.0	209.55	28.45	23.75	1½"-12	26.20	35.20	F12	125.0	M12x16	37.00	1000
3"	inch	3.15	14.0	14.12	4.33	4.98	7.71	10.10	36.06	8.25	1.12	0.94	UNF-2A	1.03	1.39		4.92		81.60	1160
DN100	mm	100.0	431.80	434.85	135.0	142.40	211.90	273.0	916.0	273.05	28.45	23.75	1½"-12	26.20	35.20	F12	125.0	M12x18	58.00	1830
4"	inch	3.94	17.0	17.12	5.31	5.61	8.34	10.75	36.06	10.75	1.12	0.94	UNF-2A	1.03	1.39		4.92		128.00	2123
DN150	mm	150.0	558.80	561.85	190.0	194.0	307.0	-	-	355.60	35.92	35.92	2"-8	40.0	46.50	F14	140.0	M16x18	126.00	4380
6"	inch	5.91	22.0	22.12	7.48	7.64	12.09	-	-	14.0	1.41	1.41	UN-2A	1.57	1.83		5.51		278.00	5081
DN200	mm	200.0	660.40	663.45	275.0	245.0	400.0	-	-	419.10	45.90	45.90	2¾"-8	50.0	55.0	F16	165.0	M20x28	314.00	8070
8"	inch	7.87	26.0	26.12	10.83	9.65	15.75	-	-	16.50	1.81	1.81	UN-2A	1.97	2.17		6.50		692.20	9361

⁽¹⁾ Due to high valve torque, pipe handle cannot be used. A manual gear or automation means should be used to operate the valve.



Floating Ball 3 Piece

Components & Materials

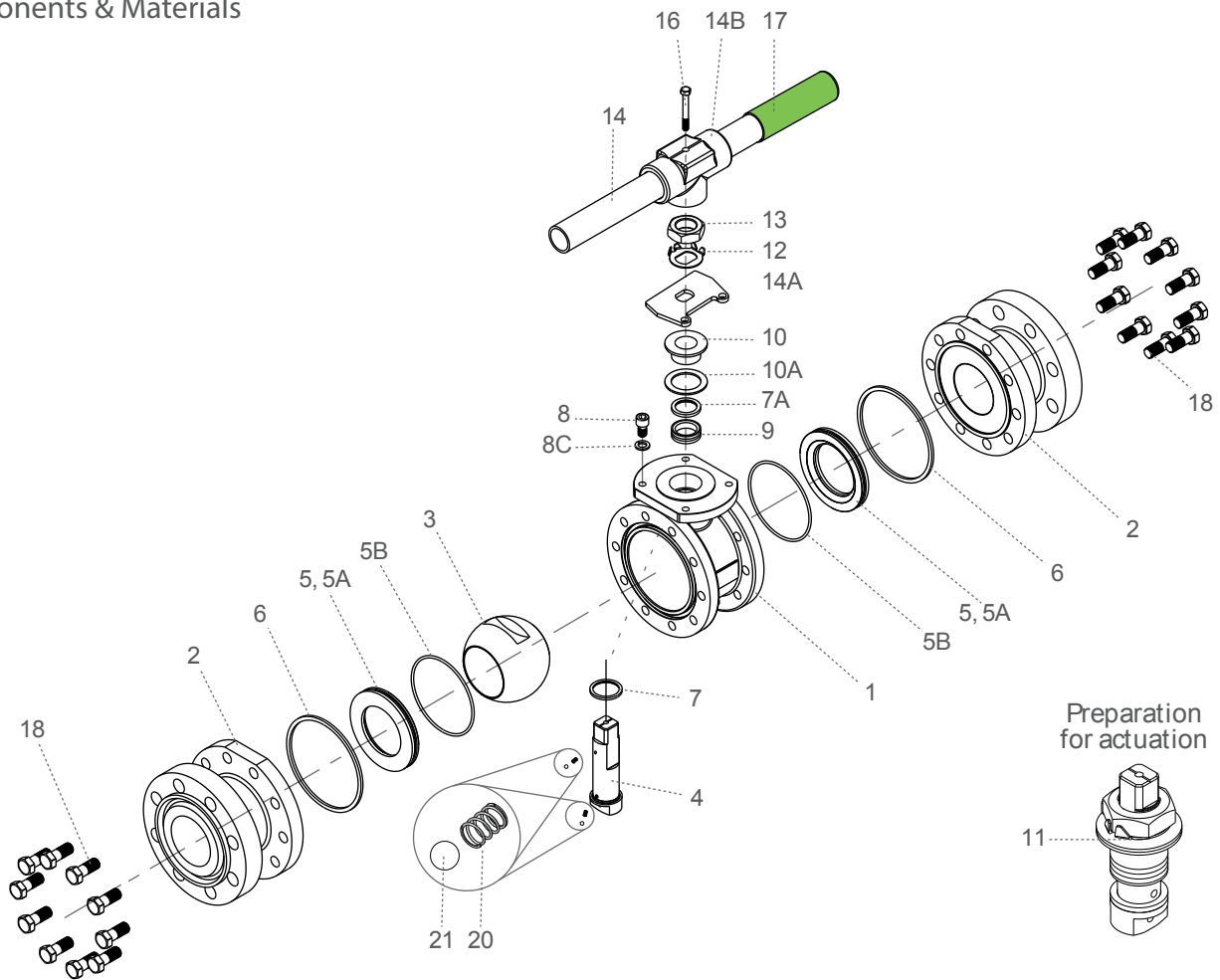

Item	Description	Material specification	Qty.
1	Body	Acc. Ordering Code	1
2	Ends	Acc. Ordering Code	2
3	Ball	Acc. Ordering Code	1
4	Stem	Acc. Ordering Code	1
5*	Seat Insert	Acc. Ordering Code	2
5A*	Seat Housing	S. Steel	2
5B*	Seat Seal	Graphite, PTFE	2
6*	Outer seal	Graphite, PTFE, Viton and NBR	2
7*	Stem Thrust Seal	PEEK, CF PEEK, PCTFE	1
7A*	Anti-Abrasion Ring	PEEK, CF PEEK, PCTFE	1
8	Stop Pin	S. Steel	1
9*	Stem Seal	CF PTFE, TFM	1
10	Follower	S. Steel	1
10A*	Slide Bearing	S. Steel	1

Item	Description	Material specification	Qty.
11	Disc Spring	S. Steel	2
12	Stem Nut	S. Steel	1
13	Tab Lock Washer	S. Steel	1
14**	Handle	S. Steel	1
14A	Stop Plate	S. Steel	1
14B	Wrench Head	S. Steel	1
16	Wrench Bolt	S. Steel	1
17	Sleeve	PVC	1
18	Body Bolts	S. Steel	20-24-32
20	Anti-Static Spring	S. Steel	2
21	Anti-Static Plunger	S. Steel	2
23	Tag (not shown)	S. Steel	1

* Maintenance kit components

** Gear operator should be used for size 6" DN150 and above (handle components are not included)



Floating Ball 3 Piece - Ordering Code System

"Mandatory option" options are marked with **green background** | "Standard offer" options are marked with **light green background**

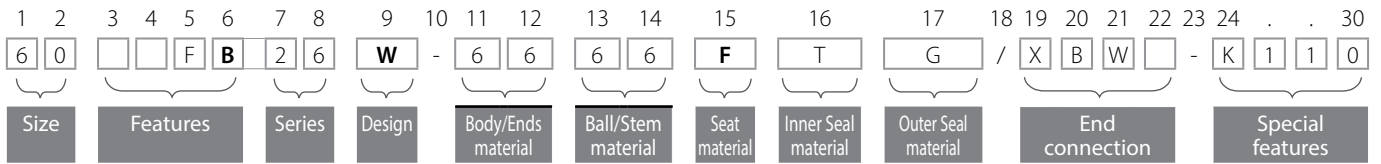

Size (1-2)		
Code	inch	mm
20	2"	50
30	3"	80
40	4"	100
60	6"	150
80	8"	200

Features (3-6)	
B	Full port
F	Fire safe
O	Clean assembly for O2 service
M	Ammonia service
K	Chlorine service

Series (7-8)	
26	Floating ball 3 piece

Design (9)	
W	HermetiX Fire - Safe

Body/Ends material (11-12)	
6	S. Steel CF8M
4	C. steel A216 WCB/A105
9	C. steel A352 LCB

Ball material (13)	
6	S. Steel316

Stem material (14)	
6	S. Steel316
M	High Strength S. Steel
Z	Inconel 718

Seat material (15)	
F	Hybrid Seat (info in special features)

Inner Seal Material (16)	
T	PTFE
G	Expanded graphite
V	Viton
B	NBR

Outer Seal Material (17)	
G	Expanded graphite
A	TFM

End Connection (19-22)	
Welded	
XBW	Extended buttweld schd. 40
XBW80	Extended buttweld schd. 80
Flanged	
600	ASME B16.5 #600 RF
PN63	EN1092 PN63 RF
PN100	EN1092 PN100 RF

Special Features (24-30)	
RTJ	Ring Type Joint
P250	Ball with Upstream Relief Hole

Valve Special Stem Seals	
HC	High Cycle service
LAX	FDA Compliant, Stem seal, Virgin Peek thrust and TFM, X shape, gasket

Hybrid Seats (24-27)	
Insert material	
K	CF PEEK
P	CF PTFE
W	PVDF
Seat Configuration	
1	Hybrid seats on upstream and downstream
Bi-Directional Hybrid Seats	
1	Round
Seal Type	
0	U+Viton
6	L+PTFE
1	U+NBR
3	U+Low Temp. NBR
5	L+PTFE+Graphite

Lifting Device

The 26 Series is equipped with a lifting device to ease installation. The maximum allowable load is indicated in the below table.

Std. port	Unit	Weight
DN50	kg	1000
2"	lb	2205
DN80	kg	3000
3"	lb	6614
DN100	kg	4400
4"	lb	9700
DN150	kg	5800
6"	lb	12787
DN200	kg	5800
8"	lb	12787

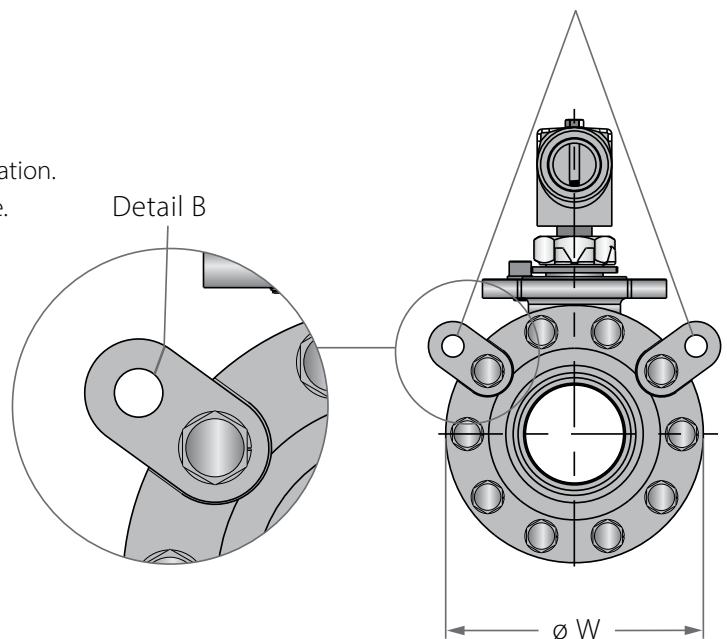

31

32

73

74

77

78



Industrial Valves

FLOATING BALL

FLANGED

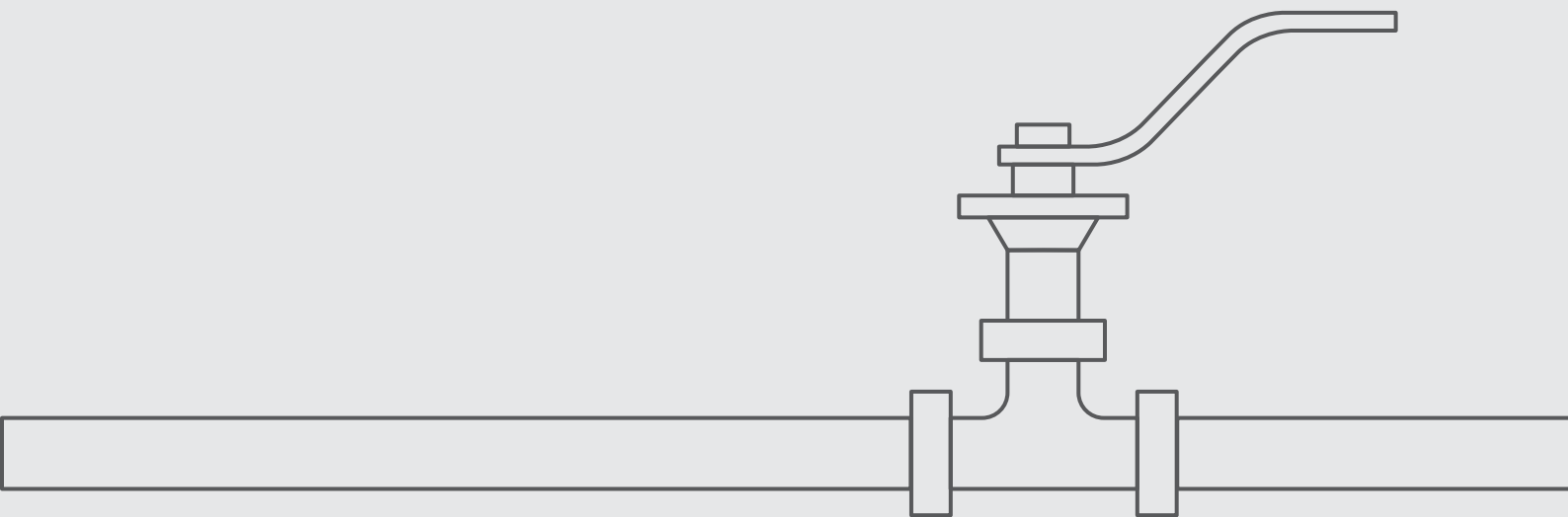

Floating Ball Flanged

Valve Dimensions

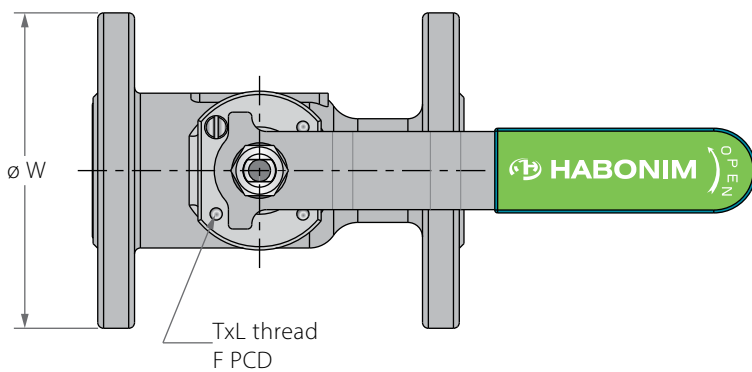
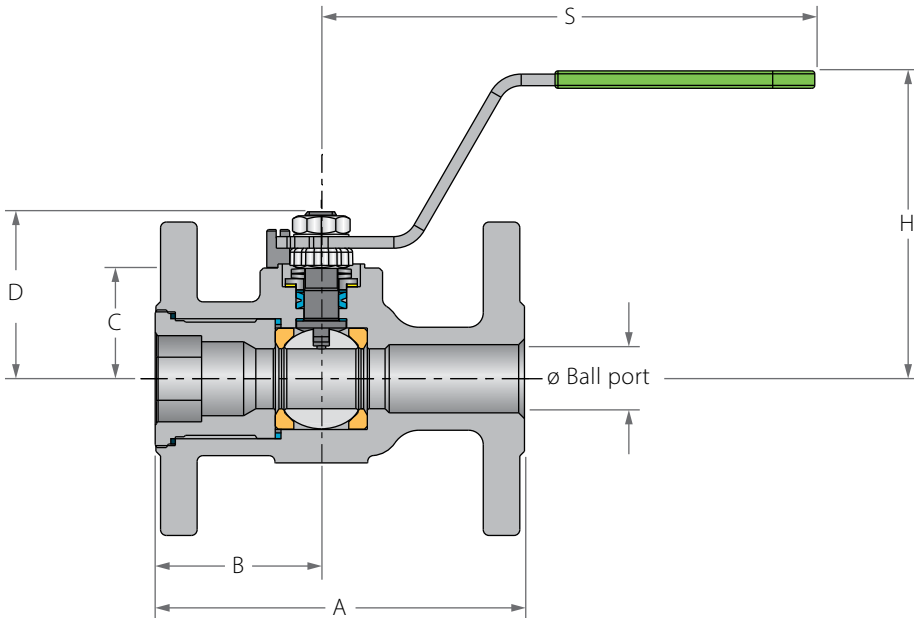

Preparation for actuation

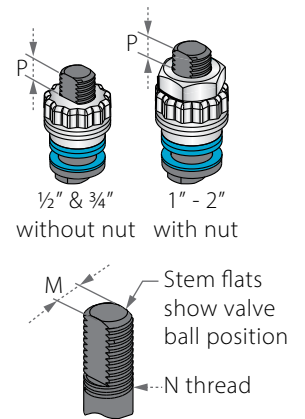

Std. port	Unit	Ball port	A		B	C	D	H	S	W		M	N	P	F	TxL	Weight kg/lb		Kv Cv	
			150	300						150	300						150	300		
DN15	mm	11.15	108.0	140	46.0	29.0	38.0	92.0	151.0	88.90	95.25	5.54	3/8" UNF	6.65	F03	36.0	M5x10	1.70	2.40	6.9
1/2"	inch	0.44	4.25	5.51	1.81	1.14	1.50	3.62	5.94	3.50	3.75	0.22		0.26		1.42		3.80	5.30	8.0
DN20	mm	14.30	117.0	152.0	49.0	31.40	40.30	94.0	151.0	98.55	163.07	5.54	3/8" UNF	6.65	F03	36.0	M5x10	2.30	3.30	10
3/4"	inch	0.56	4.61	6.0	1.93	1.24	1.59	3.70	5.94	3.88	6.42	0.22		0.26		1.42		5.10	7.30	12
DN25	mm	20.60	127.0	165.0	57.0	38.20	55.60	103.50	170.0	107.95	123.95	7.54	7/16" UNF	7.40	F04	42.0	M5x10	3.10	4.60	28
1"	inch	0.81	5.0	6.50	2.25	1.50	2.19	4.07	6.69	4.25	4.88	0.30		0.29		1.65		7.30	10.20	32
DN40	mm	31.80	165.0	190.0	62.0	43.60	73.10	119.20	220.50	127.0	155.52	8.71	9/16" UNF	8.50	F05	50.0	M6x12	5.50	8.70	69
1 1/2"	inch	1.25	6.50	7.50	2.44	1.72	2.88	4.70	8.68	5.0	6.10	0.34		0.33		1.97		12.20	19.30	80
DN50	mm	38.20	178.0	216.0	68.0	48.30	77.80	123.90	220.50	152.40	165.10	8.71	9/16" UNF	8.50	F05	50.0	M6x12	8.10	10.80	102
2"	inch	1.50	7.0	8.50	2.67	1.90	3.06	4.88	8.68	6.0	6.50	0.34		0.33		1.97		18.00	24.00	118



Floating Ball Flanged

Components & Materials

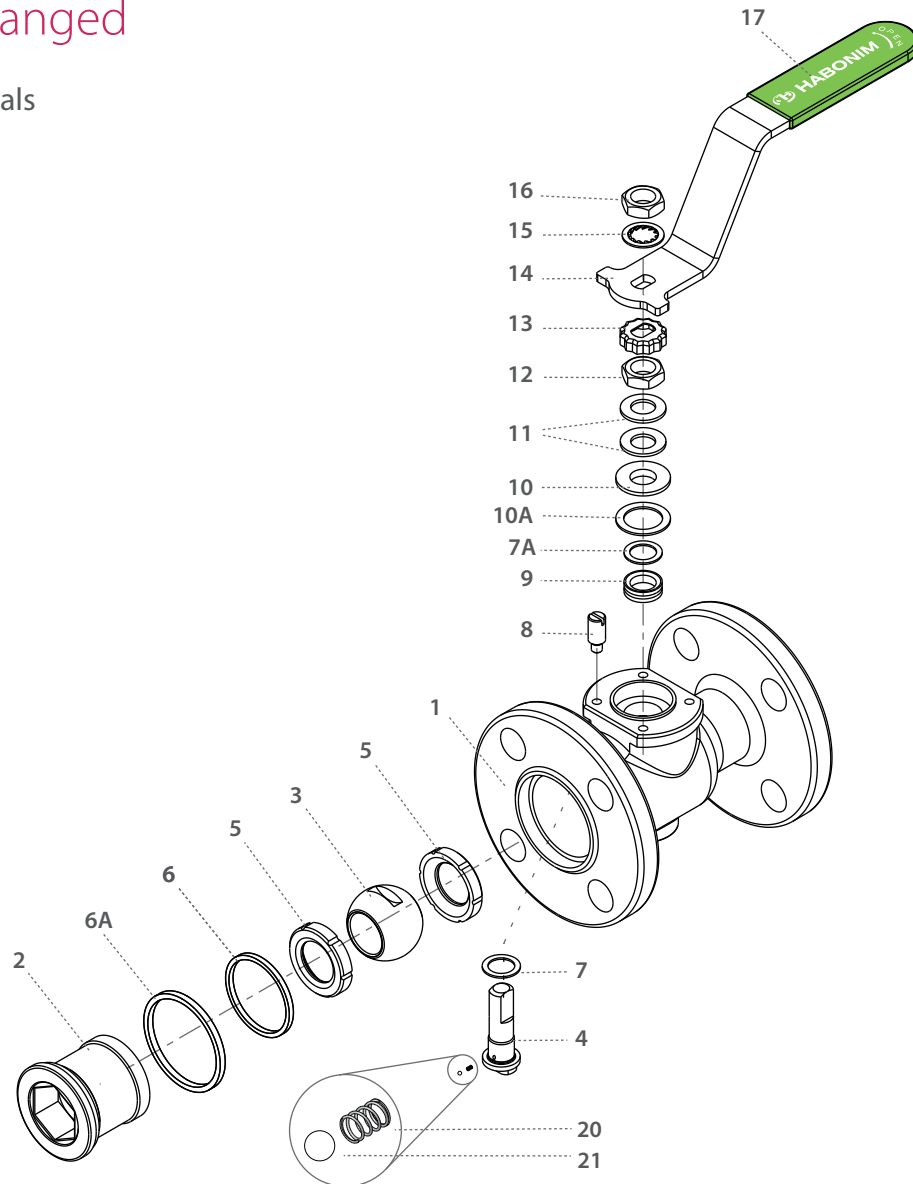

Item	Description	Material specification	Qty.
1	Body	Acc. Ordering Code	1
2	Plug	Acc. Ordering Code	1
3	Ball	Acc. Ordering Code	1
4	Stem	Acc. Ordering Code	1
5*	Seat	Acc. Ordering Code	2
6*	Inner Seal	PTFE	1
6A*	Outer Seal	Acc. Ordering Code	1
7*	Stem Thrust Seal	VIRGIN PEEK, PCTFE (KEL-F)	1
7A*	Anti-Abrasion Ring	VIRGIN PEEK, PCTFE (KEL-F)	1
8	Stop Pin	S. Steel	1
9*	Stem Seal	CF PTFE, TFM	1
10	Follower	S. Steel	1

Item	Description	Material specification	Qty.
10A*	Slide Bearing	S. Steel	1
11	Disc Spring	S. Steel	2
12	Stem Nut	S. Steel	1
13	Locking Clip	S. Steel	1
14	Handle	S. Steel	1
15	Serrated Washer	S. Steel	1
16	Handle Nut	S. Steel	1
17	Sleeve	PVC	1
20	Anti-Static Spring	S. Steel	1
21	Anti-Static Plunger	S. Steel	1
23	Tag (not shown)	S. Steel	1

* Maintenance kit components

Floating Ball Flanged

Valve Dimensions

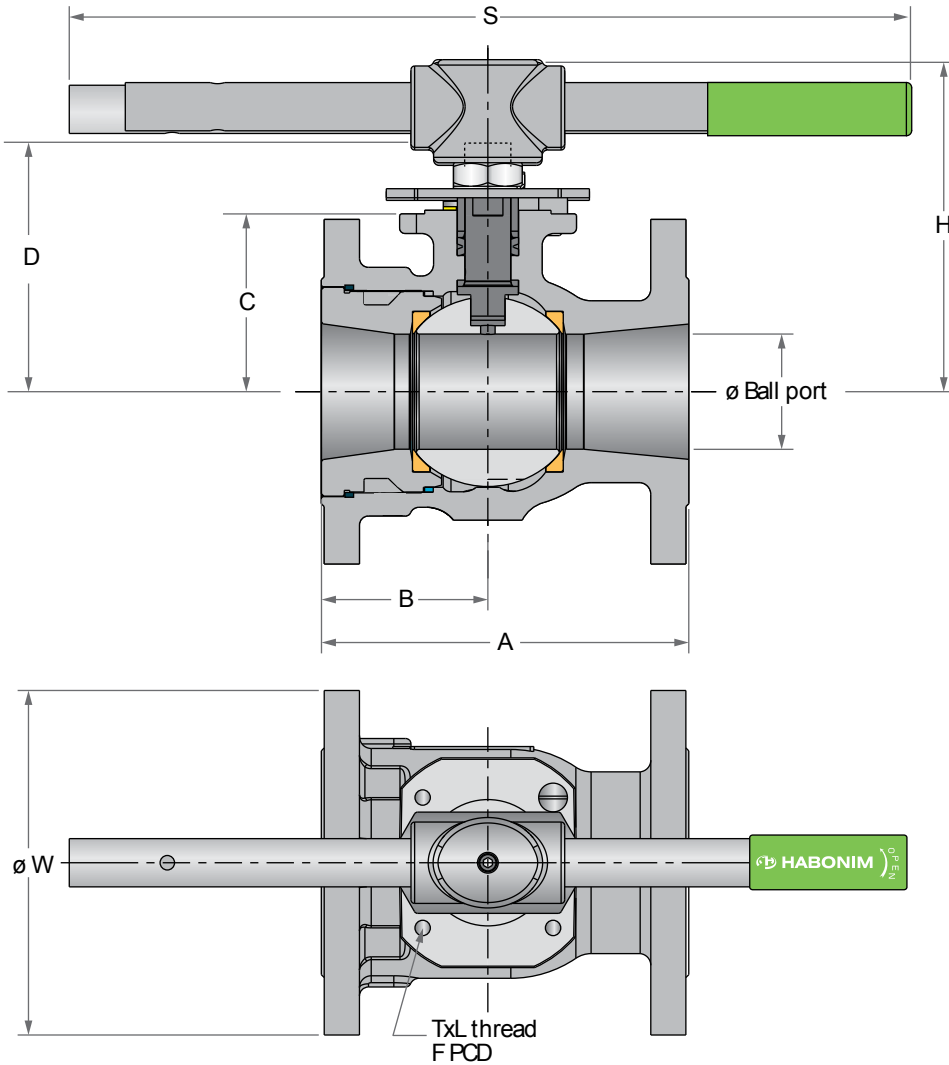

Preparation for actuation

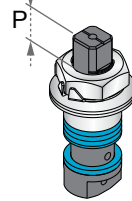

Stem grooves show valve ball position

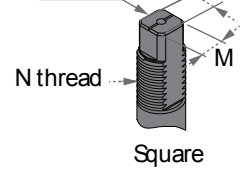

Std. port	Unit	Ball port	A		B	C	D	H	S	W		M	M-DD	N	P	F	TxL	Weight kg/lb		Kv
			150	300						150	300							150	300	
DN80	mm	63.50	203.0	284.0	92.0	98.40	145.0	185.10	400.0	190.50	209.55	18.90	15.90	1"-14	16.70	102.0	M10x20	18.00	22.70	300
3"	inch	2.50	8.0	11.18	3.62	3.88	5.72	7.28	15.75	7.50	8.25	0.74	0.63	UNS-2A	0.66	4.02	M10x20	40.00	50.40	348
DN100	mm	82.60	229.0	305.0	102.0	114.10	161.0	201.0	610.0	228.60	254.0	18.90	15.90	1"-14	16.70	102.0	M10x20	28.20	36.30	615
4"	inch	3.25	9.0	12.0	4.0	4.49	6.34	7.91	24.01	9.0	10.0	0.74	0.63	UNS-2A	0.66	4.02	M10x20	62.80	80.60	713
DN150	mm	111.10	267.0	403.20	108.0	157.40	226.0	285.90	916.0	279.40	317.50	28.45	23.75	1½"-12	26.20	125.0	M12x20	41.00	69.00	872
6"	inch	4.38	10.50	15.88	4.25	6.20	8.91	11.25	36.08	11.0	12.50	1.12	0.94	UNF-2A	1.03	4.92	M12x20	91.00	153.00	1012
DN200	mm	144.40	292.0	419.0	163.50	185.20	254.0	313.60	916.0	342.90	381.0	28.45	23.75	1½"-12	26.20	125.0	M12x20	82.00	105.00	1552
8"	inch	5.68	11.50	16.50	5.37	7.30	10.0	12.34	36.08	13.50	15.0	1.12	0.94	UNF-2A	1.03	4.92	M12x20	182.00	233.00	1800



Floating Ball Flanged

Components & Materials

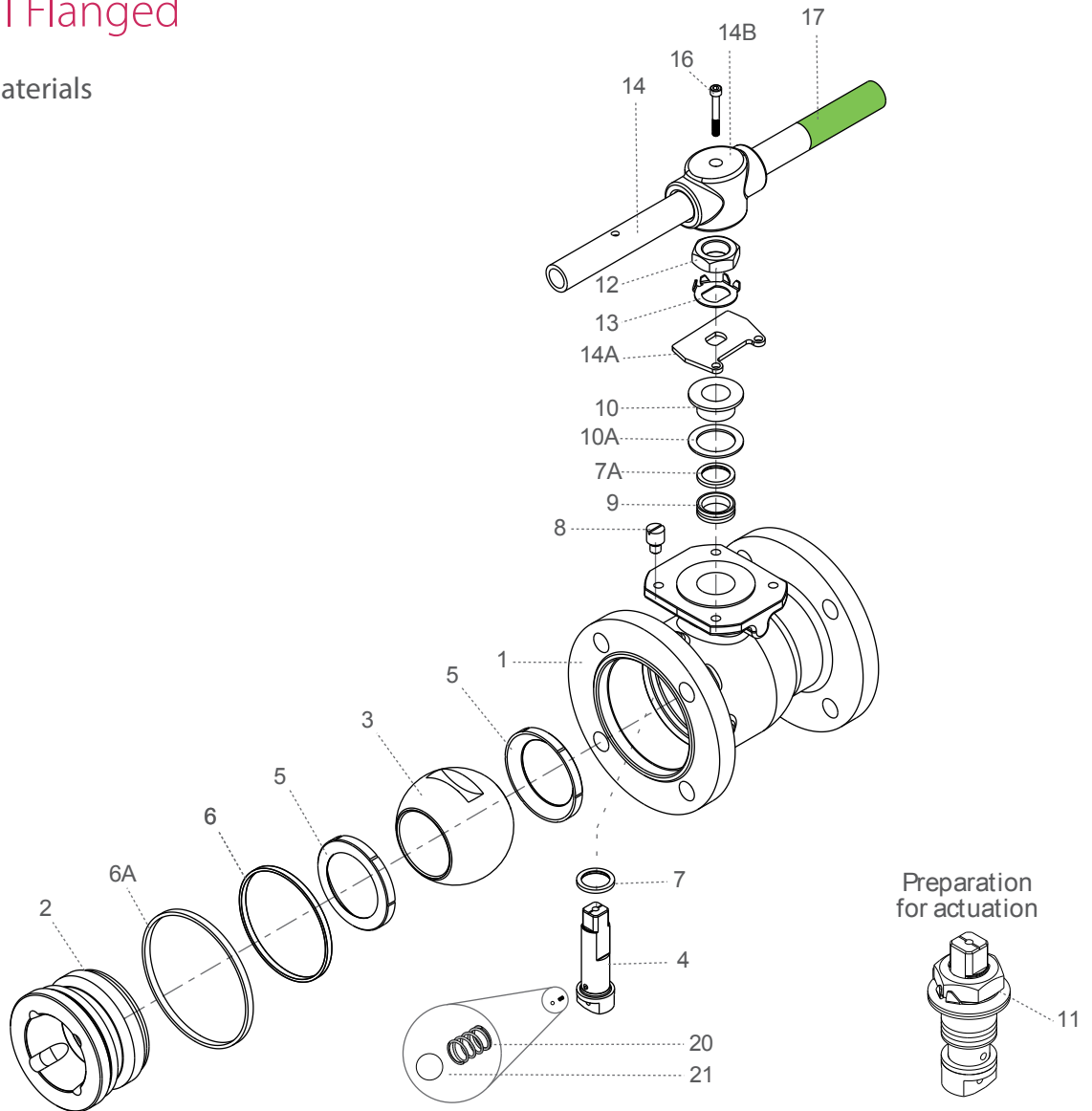

Item	Description	Material specification	Qty.
1	Body	Acc. Ordering Code	1
2	Plug	Acc. Ordering Code	1
3	Ball	Acc. Ordering Code	1
4	Stem	Acc. Ordering Code	1
5*	Seat	Acc. Ordering Code	2
6*	Inner Seal	PTFE	1
6A*	Outer Seal	Acc. Ordering Code	1
7*	Stem Thrust Seal	VIRGIN PEEK, PCTFE (KEL-F)	1
7A*	Anti-Abrasion Ring	VIRGIN PEEK, PCTFE (KEL-F)	1
8	Stop Pin	S. Steel	1
9*	Stem Seal	CF PTFE, TFM	1
10	Follower	S. Steel	1
10A*	Slide Bearing	S. Steel	1

Item	Description	Material specification	Qty.
11	Disc Spring	S. Steel	2
12	Stem Nut	S. Steel	1
13	Tab Lock Washer	A240 304	1
14	Handle	C. Steel	1
14A	Stop Plate	S. Steel	1
14B	Wrench Head	S. Steel	1
16	Wrench Bolt	S. Steel	1
17	Sleeve	PVC	1
20	Anti-Static Spring	S. Steel	2
21	Anti-Static Plunger	S. Steel	2
23	Tag (not shown)	S. Steel	1

* Maintenance kit components

Floating Ball Flanged

Valve Dimensions

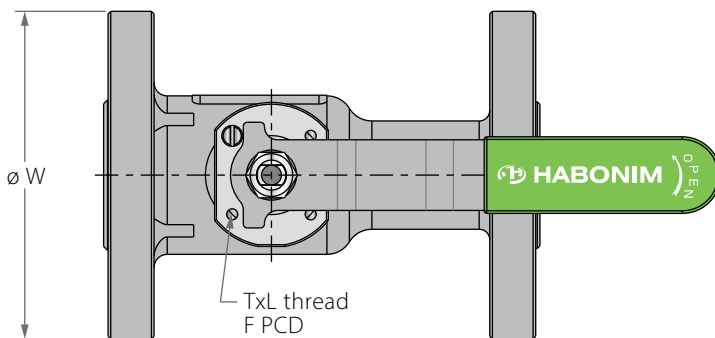
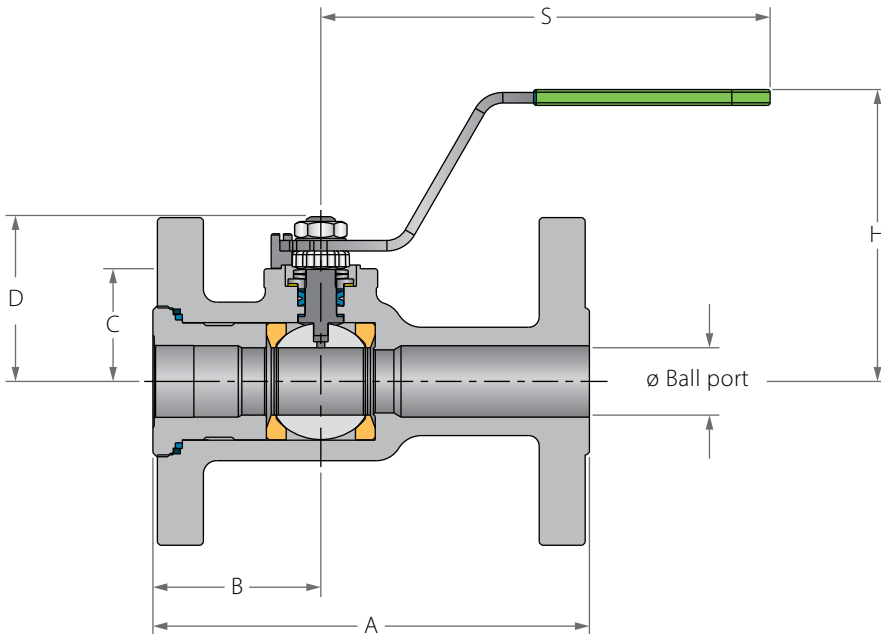

Preparation for actuation

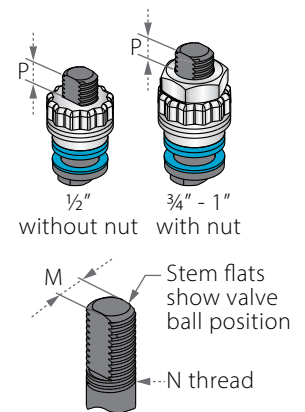

Full port	Unit	Ball port	73 74										F	TxL	Weight kg/lb		Kv			
			A		B	C	D	H	S	W		M			N	P		150	300	Cv
			150	300						150	300									
DN15	mm	14.3	108.0	140.0	47.0	31.40	40.5	94.0	151.0	89.0	95.0	5.54	3/8"	6.65	F03	36	M5x10	1.8	2.3	28
1/2"	inch	0.56	4.25	5.51	1.85	1.25	1.59	3.70	5.95	3.50	3.74	0.22	UNF-2A	0.26	F03	1.42	M5x10	4	5.1	32
DN20	mm	20.6	117.0	152.0	57.0	38.20	55.6	103.5	170.0	98.0	117.0	7.54	7/16"	7.4	F04	42	M5x10	2.2	3.3	46
3/4"	inch	0.81	4.61	5.98	2.24	1.50	2.19	4.08	6.69	3.86	4.61	0.30	UNF-2A	0.29	F04	1.65	M5x10	4.8	7.3	53
DN25	mm	25.4	127.0	165.0	62.0	42.70	60.3	108.0	170.0	108.0	124	7.54	7/16"	7.4	F04	42	M5x10	3.2	4.6	80
1"	inch	1.0	5.0	6.50	2.44	1.68	2.37	4.25	6.69	4.25	4.88	0.30	UNF-2A	0.29	F04	1.65	M5x10	7	10.1	93

Full port	Unit	Ball port	78										F	TxL	Weight kg/lb		Kv				
			A		B	C	D	H	S	W	M	N			P	F1		F4	F1	F4	Cv
			F1	F4																	
DN15	mm	14.3	130.0	115.0	48.0	31.50	40.5	98.6	151.0	95.0	5.54	3/8"	6.65	F03	36	M5x10	2.2	2.1	28		
1/2"	inch	0.56	5.12	4.53	1.89	1.24	1.59	3.88	5.95	3.74	0.22	UNF-2A	0.26	F03	1.42	M5x10	4.8	4.6	32		
DN20	mm	20.6	150	120.0	58.0	38.30	56.5	105.0	170.0	105.0	7.54	7/16"	7.4	F04	42	M5x10	3.2	3	46		
3/4"	inch	0.81	5.91	4.72	2.28	1.51	2.22	4.13	6.69	4.13	0.30	UNF-2A	0.29	F04	1.65	M5x10	7	6.6	53		
DN25	mm	25.4	160.0	125.0	63.5	41.80	61.0	108.0	170.0	115.0	7.54	7/16"	7.4	F04	42	M5x10	4.2	4	80		
1"	inch	1.0	6.30	4.92	2.50	1.65	2.40	4.25	6.69	4.53	0.30	UNF-2A	0.29	F04	1.65	M5x10	9.2	8.8	93		



Floating Ball Flanged

Components & Materials

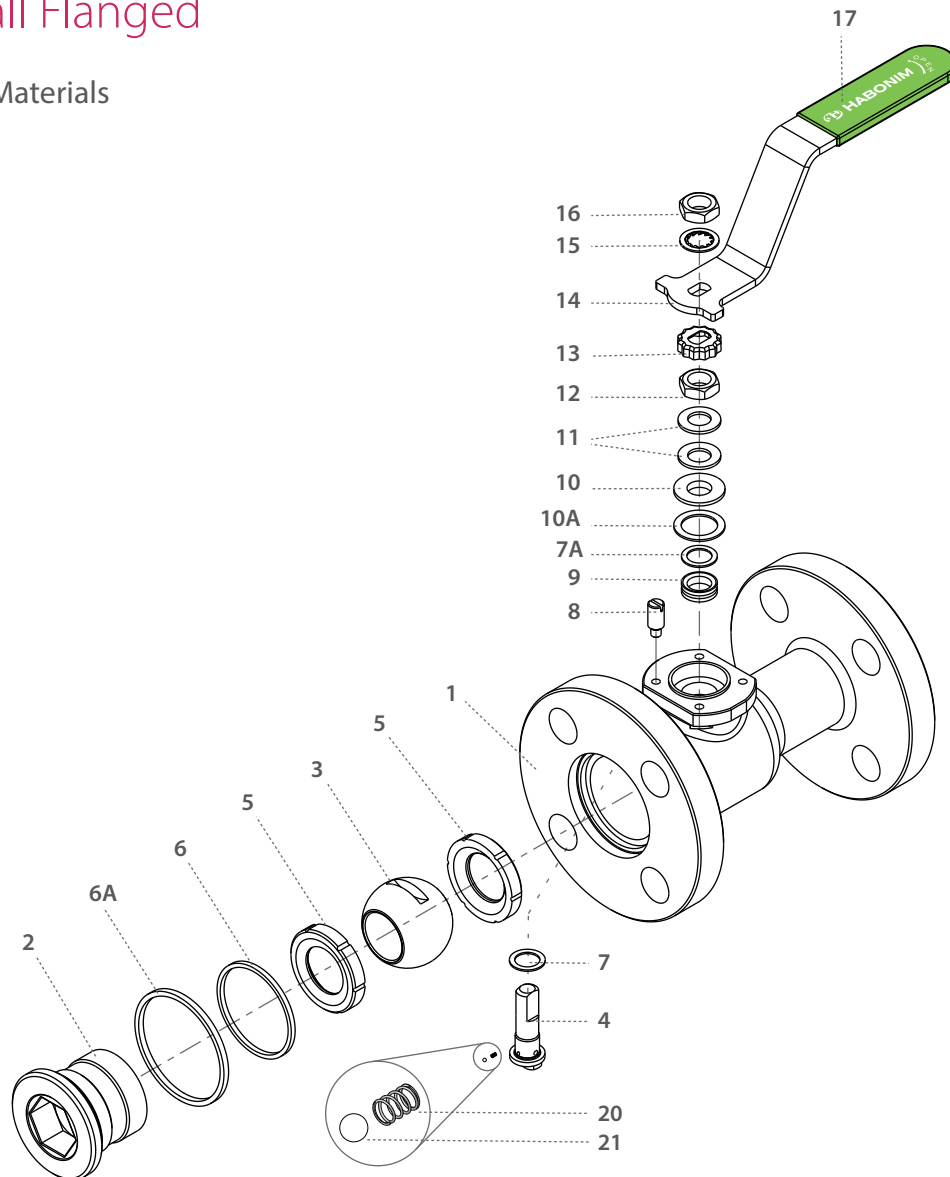

Item	Description	Material specification	Qty.
1	Body	Acc. Ordering Code	1
2	Insert	A351 CF8M, A216 WCB, A351 CN7M, A494	1
3	Ball	Acc. Ordering Code	1
4	Stem	Acc. Ordering Code	1
5*	Seat	Acc. Ordering Code	2
6*	Inner Seal	PTFE	1
6A*	Outer Seal	Acc. Ordering Code	1
7*	Stem Thrust Seal	VIRGIN PEEK, PCTFE (KEL-F)	1
7A*	Anti-Abrasion Ring	VIRGIN PEEK, PCTFE (KEL-F)	1
8	Stop Pin	S. Steel	1
9*	Stem Seal	CF PTFE, TFM	1
10	Follower	S. Steel	1

Item	Description	Material specification	Qty.
10A*	Slide Bearing	S. Steel	1
11	Disc Spring	S. Steel	2
12	Stem Nut	S. Steel	1
13	Locking Clip	S. Steel	1
14	Handle	S. Steel	1
15	Serrated Washer	S. Steel	1
16	Handle Nut	S. Steel	1
17	Sleeve	PVC	1
20	Anti-Static Spring	S. Steel	1
21	Anti-Static Plunger	S. Steel	1
23	Tag (not shown)	S. Steel	1

* Maintenance kit components

Floating Ball Flanged

Valve Dimensions

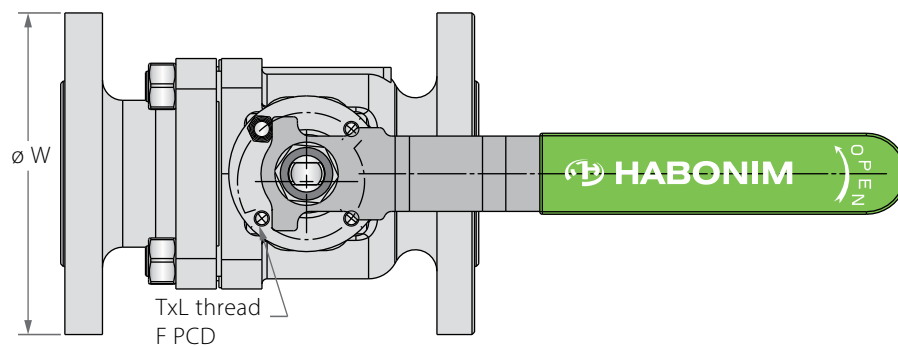
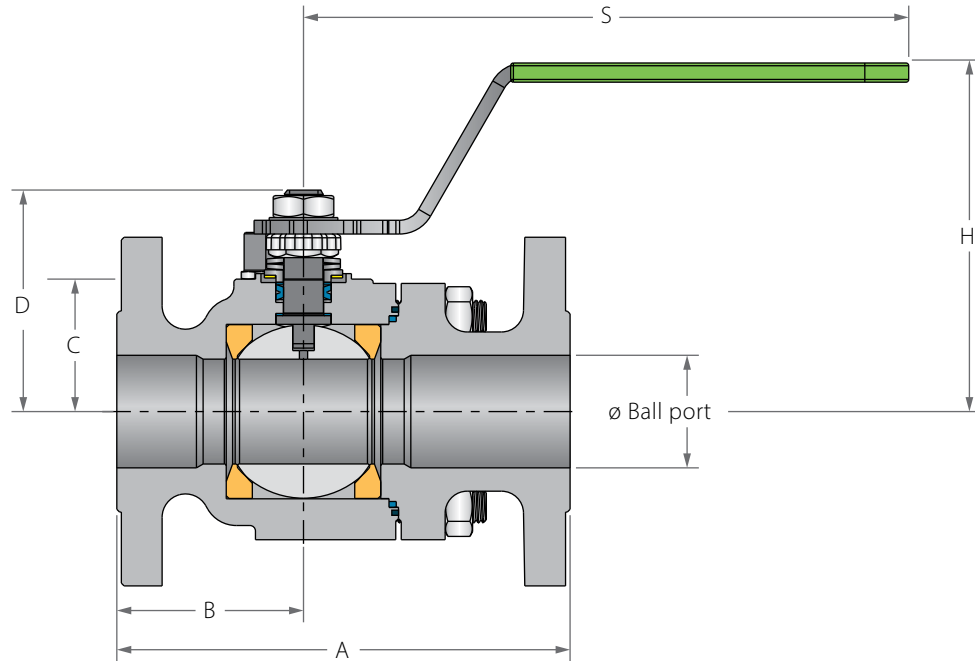

Preparation for actuation

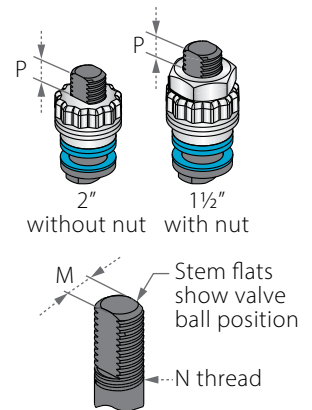

73 74																					
Full port	Unit	Ball port	A		B		C	D	H	S	W		M	N	P	F	TxL	Weight kg/lb		Kv	
			150	300	150	300					150	300						150	300		150
DN32	mm	31.8	140.0	178.0	59.0	-	49.0	73.0	120.5	220.1	115.0	135.0	8.71	% UNF	8.5	F05	50	M6x12	-	-	-
1¼"	inch	1.25	5.51	7.0	23.22	-	1.92	2.87	4.74	8.66	4.53	5.31	0.34	% UNF	0.33	F05	1.97	M6x12	-	-	-
DN40	mm	38.1	165.0	190.0	68.0	80.4	48.30	77.8	124.0	220.1	12.07	156.0	8.71	% UNF	8.5	F05	50	M6x12	6.6	9.8	220
1½"	inch	1.50	6.50	7.50	26.76	31.65	1.90	3.06	4.88	8.66	5.0	6.14	0.34	% UNF	0.33	F05	1.97	M6x12	14.5	21.5	255
DN50	mm	50.0	178.0	216.0	69.1	75.2	70.0	88.0	134.2	220.1	152.0	165.0	8.71	% UNF	13.5	F07	70	M8x12	13	15	430
2"	inch	2.0	7.0	8.50	27.20	29.61	2.75	3.46	5.28	8.66	5.98	6.50	0.34	% UNF	0.53	F07	2.75	M8x12	28.6	33	499

78																			
Full port	Unit	Ball port	A		B	C	D	H	S	W	M	N	P	F	TxL	Weight kg/lb		Kv	
			F1	F4												F1	F4		Cv
DN32	mm	31.8	180.0	130.0	55.88	49.0	72.89	121.4	220.1	140.0	8.71	% UNF	8.5	F05	50	M6x12	-	-	-
1¼"	inch	1.25	7.10	5.11	2.20	1.92	2.87	4.78	8.66	5.51	0.34	% UNF	0.33	F05	1.97	M6x12	-	-	-
DN40	mm	38.1	200.0	140.0	65.9	48.30	77.8	124.0	220.1	150.0	8.71	% UNF	8.5	F05	50	M6x12	10.9	10.3	220
1½"	inch	1.50	7.87	5.51	2.59	1.90	3.06	4.88	8.66	5.91	0.34	% UNF	0.33	F05	1.97	M6x12	24	22.7	255
DN50	mm	50.0	230.0	150.0	60.7	78.0	119.0	137.3	220.1	165.0	8.71	% UNF	13.5	F07	70	M8x12	15	13	430
2"	inch	2.0	9.06	5.91	2.39	3.07	4.69	5.41	8.66	6.50	0.34	% UNF	0.53	F07	2.75	M8x12	33	28.6	499



Floating Ball Flanged

Components & Materials

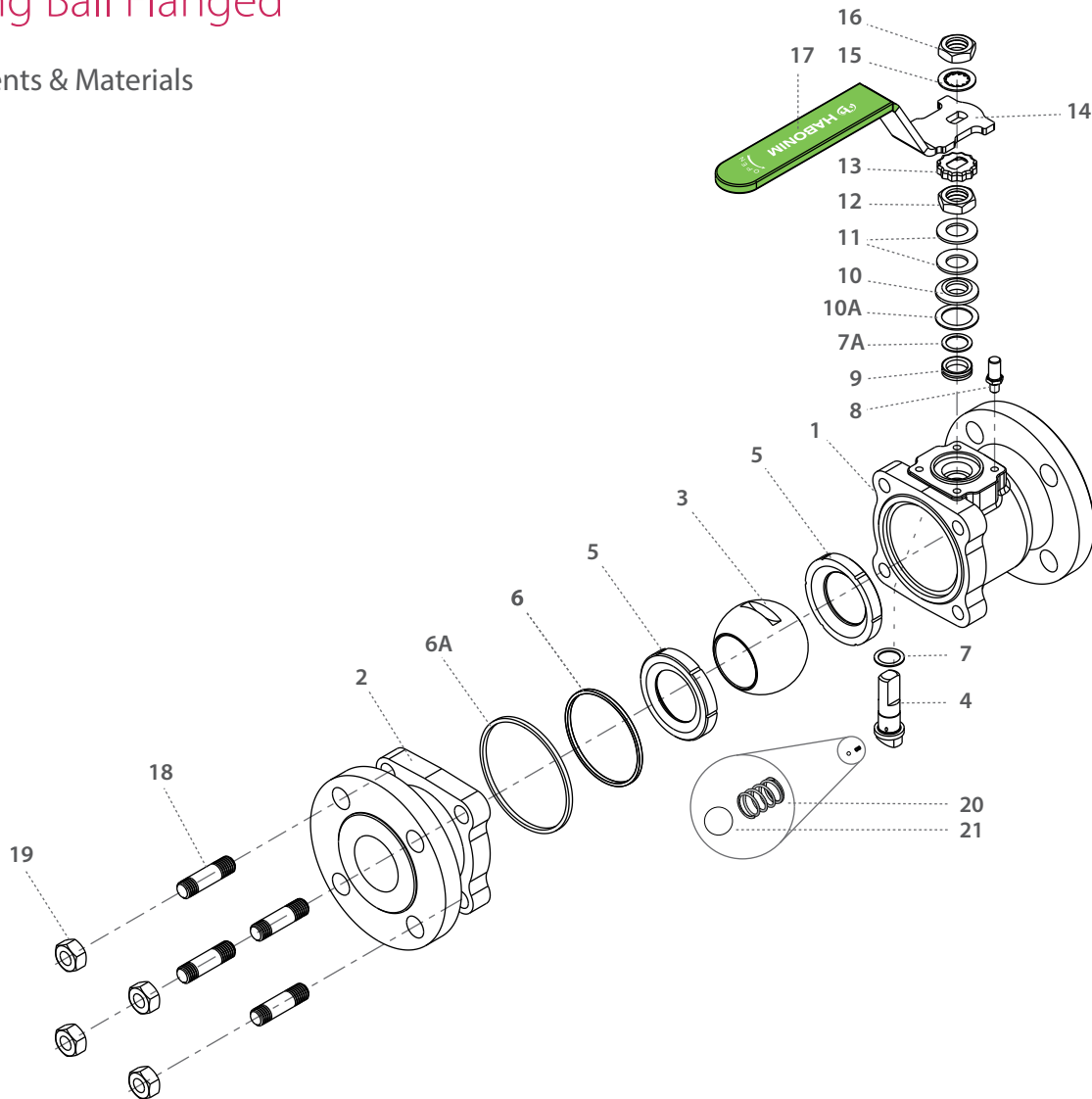

Item	Description	Material specification	Qty.
1	Body	Acc. Ordering Code	1
2	End	Acc. Ordering Code	1
3	Ball	Acc. Ordering Code	1
4	Stem	Acc. Ordering Code	1
5*	Seat	Acc. Ordering Code	2
6*	Inner Seal	PTFE	1
6A*	Outer Seal	Acc. Ordering Code	1
7*	Stem Thrust Seal	VIRGIN PEEK, PCTFE (KEL-F)	1
7A*	Anti-Abrasion Ring	VIRGIN PEEK, PCTFE (KEL-F)	1
8	Stop Pin	S. Steel	1
9*	Stem Seal	CF PTFE, TFM	1
10	Follower	S. Steel	1
10A*	Slide Bearing	S. Steel	1

Item	Description	Material specification	Qty.
11	Disc Spring	S. Steel	2
12	Stem Nut	S. Steel	1
13	Locking Clip	S. Steel	1
14	Handle	S. Steel	1
15	Serrated Washer	S. Steel	1
16	Handle Nut	S. Steel	1
17	Sleeve	PVC	1
18	Body Bolts	S. Steel	4
19	Body Nuts	S. Steel	4
20	Anti-Static Spring	S. Steel	1
21	Anti-Static Plunger	S. Steel	1
23	Tag (not shown)	S. Steel	1

* Maintenance kit components

73

74

2½"-8" | DN65-DN200 | CLASS 150/300

77

3"-8" | DN80-DN200 | PN 16

78

2½" | DN65 | PN40

Floating Ball Flanged

Valve Dimensions

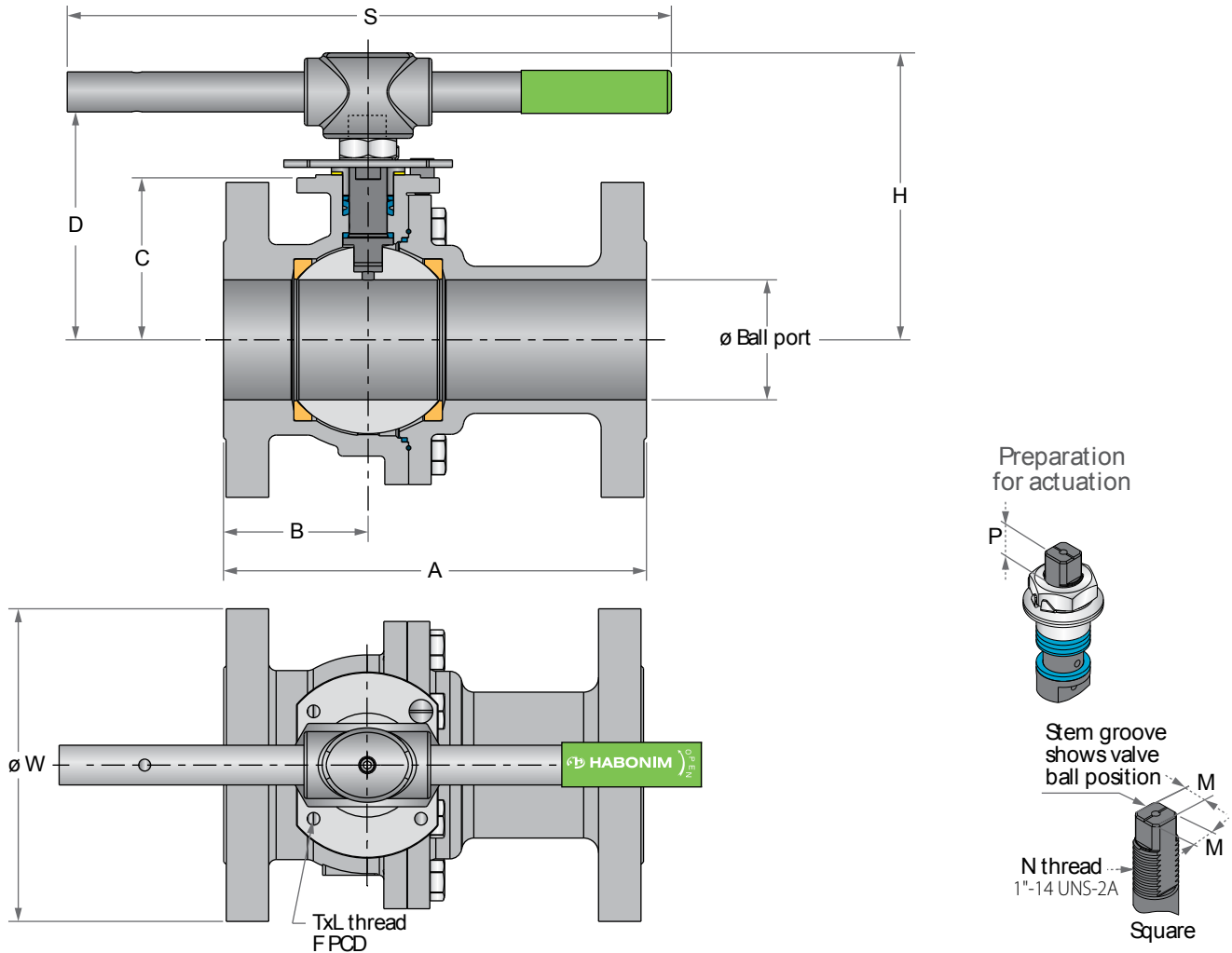

Preparation for actuation

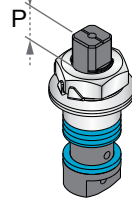

Stem groove shows valve ball position

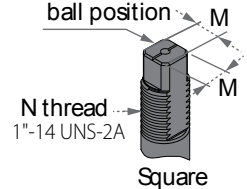
N thread
1"-14 UNS-2A

Square

73 74 2½"-8"

Full port	Unit	Ball port	A		B		C	D	H	S	W		M	M-DD	N	P	F	TxL	Weight kg/lb		Kv	
			150	300	150	300					150	300							150	300		150
DN65	mm	65.0	190.0	241.0	83.0	-	119.0	165.5	194.8	400.0	180.0	190.0	18.9	15.9	1"-14	16.7	F10	102	M10x20	-	-	-
2½"	inch	2.56	7.48	9.48	3.26	-	4.76	6.51	7.67	15.75	7.08	7.48	0.74	0.63	UNS-2A	0.66	4.02	M10x20	-	-	-	
DN80	mm	80.0	203.0	282.5	77.5	96.4	108.0	154.6	194.8	400.0	191.0	210.0	18.9	15.9	1"-14	16.7	F10	102	M10x20	22	28.2	1111
3"	inch	3.20	7.99	11.12	3.05	3.80	4.25	6.09	7.67	15.75	7.52	8.27	0.74	0.63	UNS-2A	0.66	4.02	M10x20	48.5	62.2	1300	
DN100	mm	100.0	228.5	304.8	84.5	104.5	124.0	170.5	211.0	610.0	230.0	254.0	18.9	15.9	1"-14	16.7	F10	102	M10x20	39	44.5	2051
4"	inch	3.94	9.0	12.0	3.33	4.11	4.88	6.69	8.31	24.02	9.06	10.0	0.74	0.63	UNS-2A	0.66	4.02	M10x20	86	98.1	2400	
DN150	mm	150.0	394.0	403.5	163.5	174.5	179.0	248.5	308.0	916.0	279.4	328.0	28.45	23.75	1½"-12	26.2	F12	125	M12x20	82	100	4615
6"	inch	5.91	15.51	15.89	6.44	6.87	7.05	9.78	12.13	36.06	11.0	12.91	1.12	0.94	UNS-2A	1.03	4.92	M12x20	180.8	220.5	5400	
DN200	mm	200.0	457.2	502.0	242.5	241.0	241.0	353.7	-	-	460.0	460.0	35.92	35.92	2"-8	37.5	F14	140	M16x240	190	225	7949
8"	inch	7.87	18.0	19.76	9.55	9.49	9.49	13.92	-	-	18.11	18.11	1.41	1.41	UNS-2A	1.48	5.51	M16x240	418.9	496	9300	

78 2½" 77 3"-8"

Full port	Unit	Ball port	A 16/40		B		C 16/40	D 16/40	H	S	W 16/40	M	M-DD	N	P	F	TxL	Weight kg/lb		Kv	
			F5/F1	F4	16	40												F5	F4		Cv
DN65	mm	65.0	-	170.0	83.0	70.0	119.0	165.5	194.8	400.0	185.0	18.9	15.9	1"-14	16.7	F10	102	M10x20	-	-	-
2½"	inch	2.56	-	6.69	3.26	2.75	4.68	6.51	7.67	15.75	7.28	0.74	0.63	UNS-2A	0.66	4.02	M10x20	-	-	-	
DN80	mm	80.0	-	180.0	77.5	-	108.0	162.0	194.8	400.0	200.0	18.9	15.9	1"-14	16.7	F10	102	M10x20	-	24	1111
3"	inch	3.20	-	7.09	3.05	-	4.25	6.40	7.67	15.75	7.87	0.74	0.63	UNS-2A	0.66	4.02	M10x20	-	52.8	1300	
DN100	mm	100.0	-	190.0	84.5	-	132.0	186.0	211.0	610.0	225.0	18.9	15.9	1"-14	16.7	F10	102	M10x20	-	30	2051
4"	inch	3.94	-	7.48	3.33	-	5.20	7.32	8.31	24.02	8.86	0.74	0.63	UNS-2A	0.66	4.02	M10x20	-	66	2400	
DN150	mm	150.0	350.0	-	163.5	-	178.0	236.0	308.0	916.0	328.0	28.45	23.75	1½"-12	26.2	F12	125	M12x20	63	-	4615
6"	inch	5.91	13.78	-	6.44	-	7.01	9.29	12.13	36.06	12.91	1.12	0.94	UNS-2A	1.03	4.92	M12x20	139	-	5400	
DN200	mm	200.0	400.0	-	242.5	-	226.0	286.0	-	-	395.0	35.92	35.92	2"-8	37.5	F14	140	M16x24	97	-	7949
8"	inch	7.87	15.75	-	9.55	-	8.91	11.26	-	-	15.55	1.41	1.41	UNS-2A	1.48	5.51	M16x24	213	-	9300	

73

74

2½"-8" | DN65-DN200 | CLASS 150/300



77

3"-8" | DN80-DN200 | PN 16

78

2½" | DN65 | PN40

Floating Ball Flanged

Components & Materials

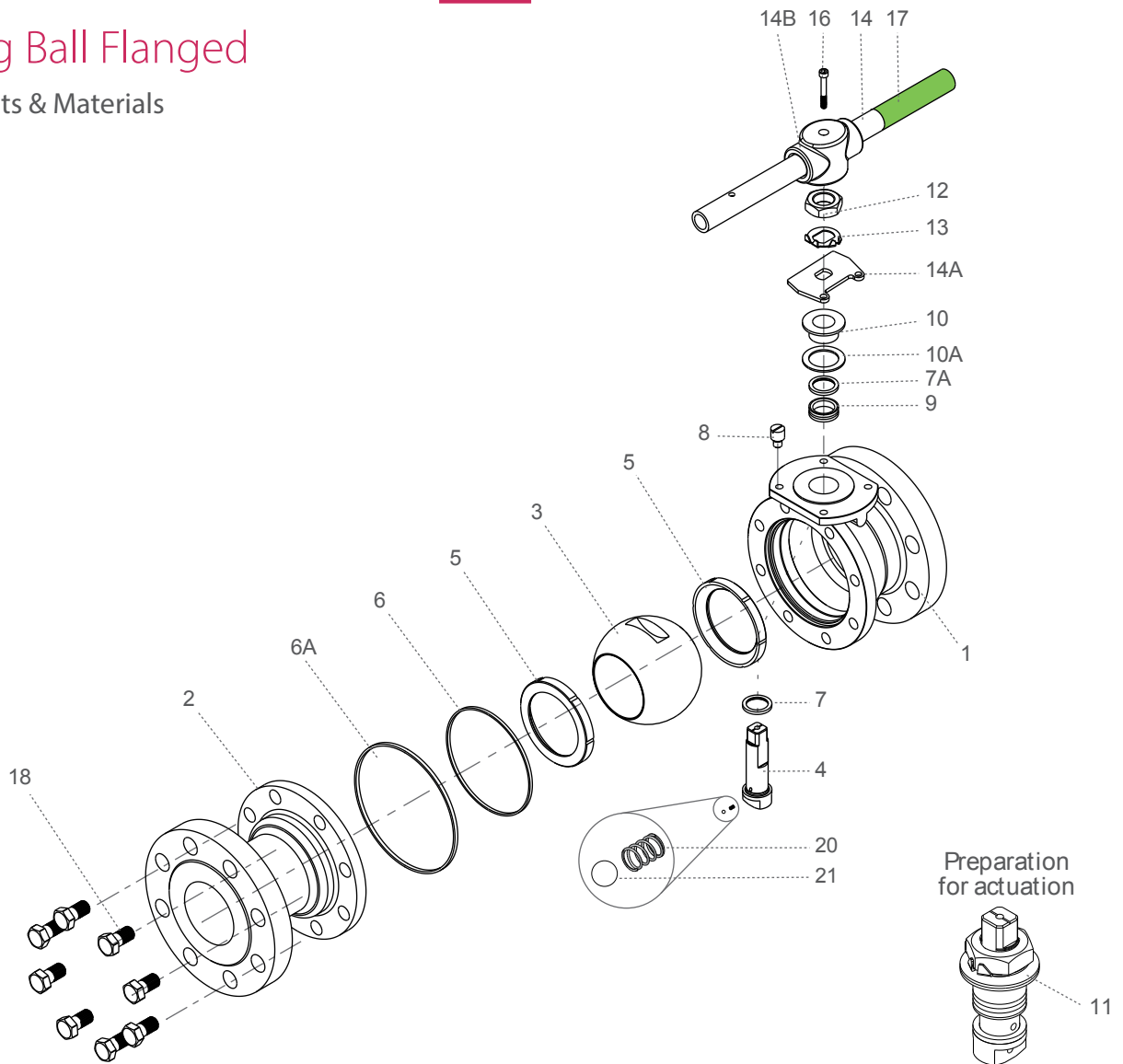

Item	Description	Material specification	Qty.
1	Body	Acc. Ordering Code	1
2	End	Acc. Ordering Code	1
3	Ball	Acc. Ordering Code	1
4	Stem	Acc. Ordering Code	1
5*	Seat	Acc. Ordering Code	2
6*	Inner Seal	PTFE	1
6A*	Outer Seal	Acc. Ordering Code	1
7*	Stem Thrust Seal	VIRGIN PEEK, PCTFE (KEL-F)	1
7A*	Anti-Abrasion Ring	VIRGIN PEEK, PCTFE (KEL-F)	1
8	Stop Pin	S. Steel	1
9*	Stem Seal	CF PTFE, TFM	1
10	Follower	S. Steel	1
10A*	Slide Bearing	S. Steel	1
11	Disc Spring	S. Steel	2

Item	Description	Material specification	Qty.
12	Stem Nut	S. Steel	1
13	Tab Lock Washer	A240 304	1
14**	Handle	C. Steel	1
14A	Stop Plate	S. Steel	1
14B	Wrench Head	S. Steel	1
16	Wrench Bolt	S. Steel	1
17	Sleeve	PVC	1
18	Body Bolts	S. Steel	8-12
20	Anti-Static Spring	S. Steel	2
21	Anti-Static Plunger	S. Steel	2
23	Tag (not shown)	S. Steel	1

* Maintenance kit components

** Gear operator should be used for size 8" DN200 (handle components are not included)



Floating Ball Flanged - Ordering Code System

"Mandatory option" options are marked with **green background** | "Standard offer" options are marked with **light green background**

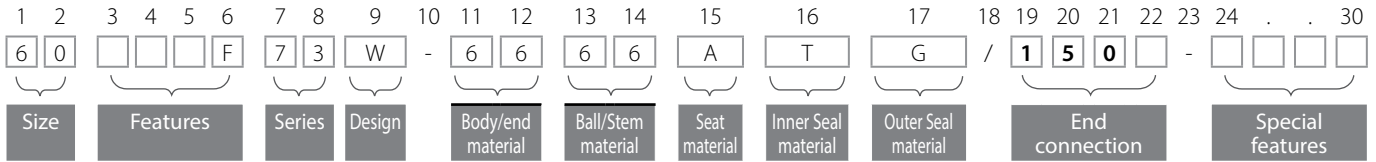

Size (1-2)		
Code	inch	mm
05	½"	15
07	¾"	20
10	1"	25
12*	1¼"	32
15	1½"	40
20	2"	50
25*	2½"	65
30	3"	80
40	4"	100
60	6"	150
80	8"	200

* only for series 73/78
25 - largest size available for series 78

Features (3-6)	
F	Fire safe
N	Control service
O	Clean assembly for O2 service
M	Ammonia service
K	Chlorine service
V	Vacuum service
H*	Hydrogen service

* for material selection - see Hydrogen Service chapter

Series (7-8)	
31	ANSI #150 std. port
32	ANSI #300 std. port
73	ANSI #150 full port
74	ANSI #300 full port
77	DIN PN 16 full port
78	DIN PN 40 full port

Design (9)	
W	Total HermetiX Integrity package
G	Total HermetiX Integrity package - FDA compliant

Body/Ends material (11-12)	
6	S. SteelCF8M/CF3M
4	C. steel
W	Hastelloy-C22
S	254SMO
D	Duplex
9	Low Temp C. steel
1	Bronze
K	Super Duplex
7	Monel
A	Alloy-20
C	Hastelloy-C276

Ball material (13)	
6	S. SteelCF8M/316
M	High Strength S. Steel
W	Hastelloy-C22
S	254SMO
D	Duplex
1	Bronze
K	Super Duplex
7	Monel
A	Alloy-20
C	Hastelloy-C276

Stem material (14)	
6	S. Steel316
M	High Strength S. Steel
Z	Inconel 718
W	Alloy-C22
S	254SMO A479
A	Alloy-20
D	Duplex A479
K	Super Duplex A479
7	Monel
C	Hastelloy-C276

Seat material (15)	
A	TFM
P	CF PTFE
K	CF PEEK
L	Virgin Peek
U	UHMWPE
C	PCTFE
Y	Delrin
W	PVDF
T	PTFE
R	15% Glass filled PTFE

Inner Seal Material (16)	
T	PTFE
A	TFM
G	Expanded graphite
U	UHMWPE
V	Viton
B	NBR

Outer Seal (17)	
G	Expanded graphite
A	TFM

End Connection (19-22)	
Flanged	
150	ASME B16.5 #150 RF
300	ASME B16.5 #300 RF
PN16	EN1092 PN16 RF
PN40	EN1092 PN40 RF

Special Features (24-30)	
P250	Ball with Upstream Relief Hole
SRS	Self Relief Seat
J2N05	Jacketed valve- number of ports (2), type (NPT) and size (½")

Valve Special Stem Seals	
LAX	FDA Compliant, Stem seal, Virgin Peek thrust and TFM, X shape, gasket
HC	High Cycle service

Face To Face sizes	
F4 *	F4 - DIN 3202-1 RF (½" - 4")
F1 **	F1 - DIN 3202-1 RF (½" - 2")
F5 ***	F5 - DIN 3202-1 RF (6")

* Standard offer: ½" to 1¼" & 2½" to 4"

** Standard offer: 1½" & 2"

*** Standard offer: 6"

47DS



Industrial Valves

FLOATING BALL

DUAL SAFE /
DOUBLE BLOCK & BLEED
3 PIECE

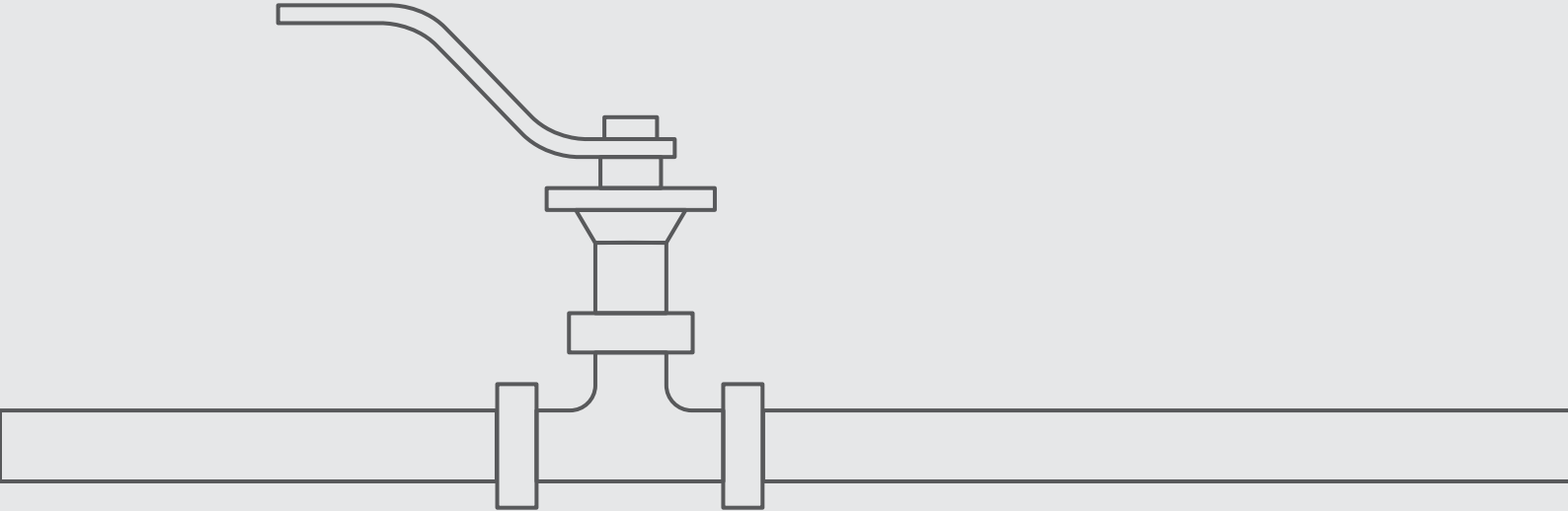

Dual Safe | Double Block & Bleed Floating Ball 3 Piece

Valve Dimensions

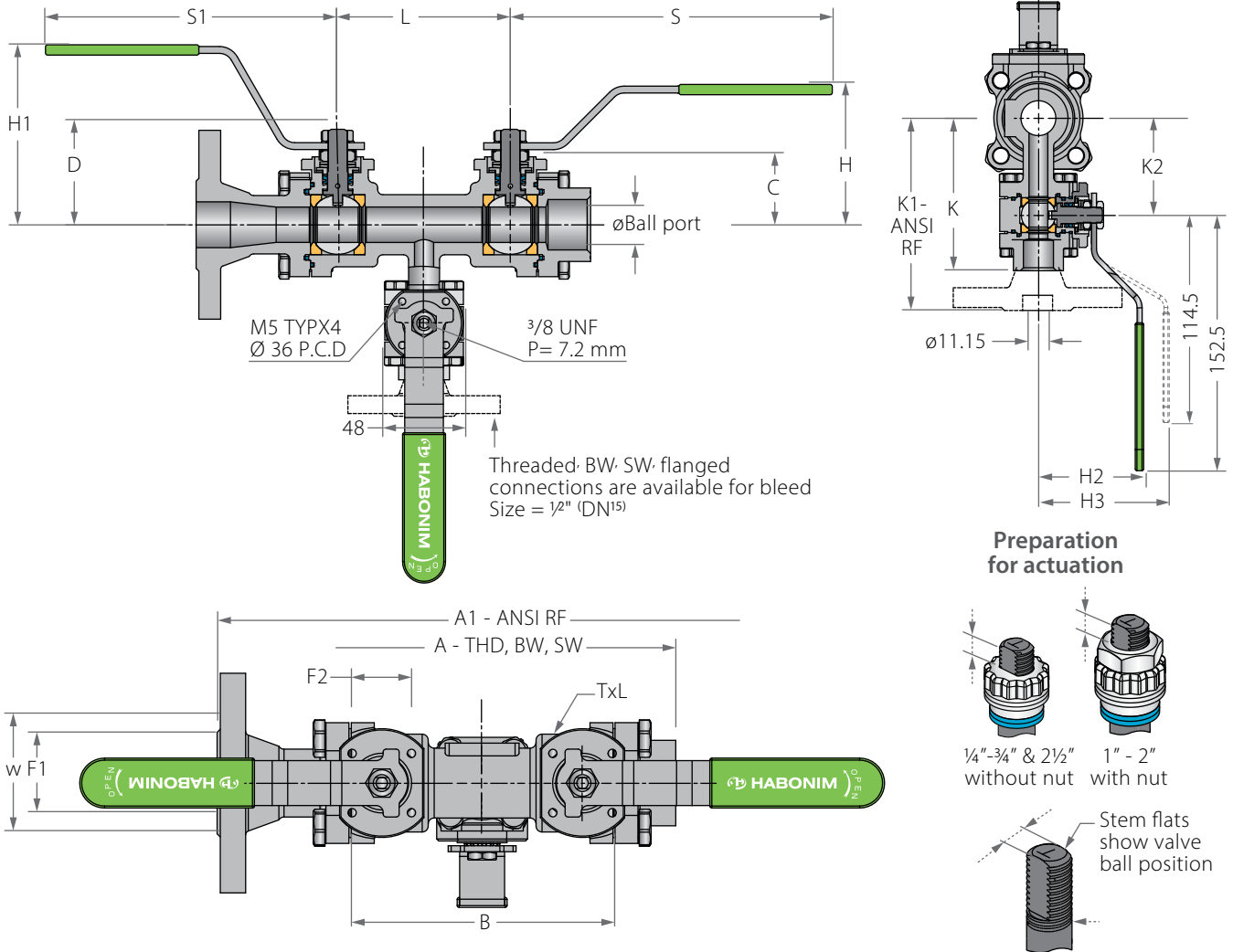

Valve Face To Face sizes are according to Habonim catalog data only, for Extended-weld/Flanged/Tri-clamp end see Face To Face sizes page.

Std. port	Full port	Unit	Ball Port	A1- RF	A	B	C	D	H	H1	H2	H3	K	K1	K2	L	S	S1	W	N	P	F	TxL	Kv	Cv
DN15	DN8, DN10	mm	11.15	212.6	138.4	93.2	29.0	37.8	91.0	47.0	62.0	92.0	90.3	127.4	57.4	72.6	114.5	152.5	47.0	3/8"	6.65	F03	36.0	M5X10	69
1/2"	1/4", 3/8"	inch	0.44	8.4	5.43	3.65	1.14	1.49	3.58	1.85	2.44	3.62	3.54	5.01	2.26	2.85	4.51	6.0	1.84	UNF	0.26	1.41	M5X10	8	
DN20	DN15	mm	14.3	234.6	153.2	107.2	31.40	40.3	93.0	49.0	62.0	92.0	86.3	127.0	53.4	82.65	114.5	152.5	53.7	3/8"	6.65	F03	36.0	M5X10	10
3/4"	1/2"	inch	0.56	9.2	6.01	4.2	1.23	1.59	3.66	1.93	2.44	3.62	3.38	5.0	2.1	3.24	4.51	6.0	2.11	UNF	0.26	1.41	M5X10	12	
DN25	DN20	mm	20.65	265.5	193.9	131.9	38.15	55.6	106.0	62.0	62.0	92.0	90.3	126	57.4	100.5	146.0	163.0	63.7	7/16"	7.4	F04	42.0	M5X10	28
1"	3/4"	inch	0.81	10.4	7.6	5.17	1.50	2.19	4.17	2.44	2.44	3.62	3.54	4.96	2.26	3.94	5.75	6.42	2.50	UNF	0.29	1.65	M5X10	32	
DN32	DN25	mm	25.5	278.9	209.3	142.2	42.65	60.2	109.5	90.5	88.0	118.0	92.3	127.2	59.4	100.95	146.0	163.0	71.7	7/16"	7.4	F04	42.0	M5X10	49
1 1/4"	1"	inch	1.0	11.0	8.21	5.58	1.67	2.37	4.31	3.56	3.46	4.65	3.62	5.0	2.34	3.96	5.75	6.42	2.81	UNF	0.29	1.65	M5X10	57	
DN40	DN32	mm	31.8	317.8	241.9	176.2	43.55	73.0	121.5	99.6	88.0	118.0	98.3	135.6	65.4	127.85	180.0	259.0	86.7	9/16"	8.5	F05	50.0	M6X12	69
1 1/2"	1 1/4"	inch	1.25	12.5	9.49	6.91	1.71	2.87	4.78	3.92	3.46	4.65	3.85	5.34	2.57	5.01	7.09	10.2	3.40	UNF	0.33	1.96	M6X12	80	
DN50	DN40	mm	38.15	343.9	254.2	184.2	48.25	77.8	125.0	103.0	88.0	118.0	104.3	149.2	71.4	127.9	180.0	259.0	96.9	9/16"	8.5	F05	50.0	M6X12	102
2"	1 1/2"	inch	1.5	13.6	9.97	7.22	1.89	3.06	4.95	4.06	3.46	4.65	4.09	5.87	2.81	5.02	7.09	10.2	3.80	UNF	0.33	1.96	M6X12	118	
DN65	DN50	mm	51.05	397.6	314.6	229.2	70.0	88.1	138.0	116.0	88.0	118.0	111.3	152.8	78.4	156.54	180.0	259.0	108.0	9/16"	13.5	F07	70.0	M8X12	208
2 1/2"	2"	inch	2.01	15.6	12.34	8.99	2.75	3.47	5.43	4.57	3.46	4.65	4.36	6.01	3.08	6.14	7.09	10.2	4.24	UNF	0.53	2.75	M8X12	241	



Dual Safe | Double Block & Bleed Floating Ball 3 Piece

Components & Materials

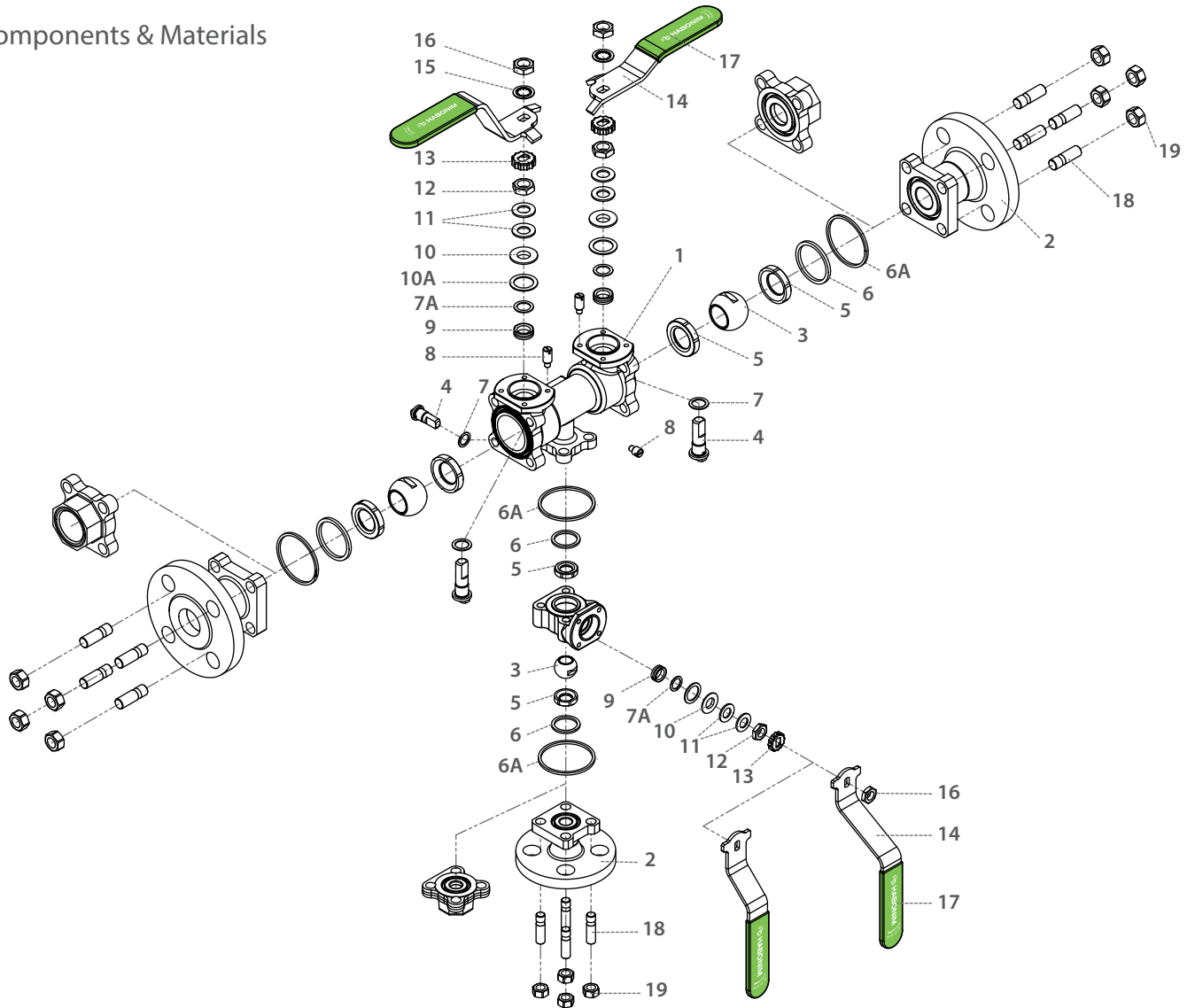

Item	Description	Material specifications	Qty.
1	Body	Acc. Ordering Code	2
2	Ends	Acc. Ordering Code	3
3	Ball	Acc. Ordering Code	3
4	Stem	Acc. Ordering Code	3
5*	Seat	Acc. Ordering Code	6
6*	Body Seal	Acc. Ordering Code	4
6A*	Outer Seal	Acc. Ordering Code	4
7*	Stem Thrust Seal	PEEK, CF PEEK, PCTFE	3
7A*	Anti-Abrasion Ring	PEEK, CF PEEK, PCTFE	3
8	Stop Pin	S. Steel	3
9*	Stem Seal	CF PTFE, TFM, Graphite	3
10	Follower	S. Steel	3
10A*	Slide Bearing	S. Steel	3

Item	Description	Material specifications	Qty.
11	Disc Spring	S. Steel	6
12	Stem Nut	S. Steel	3
13	Locking Clip	S. Steel	3
14	Handle	S. Steel	3
15	Serrated Washer	S. Steel	3
16	Handle Nut	S. Steel	3
17	Sleeve	PVC	3
18	Body Bolt	S. Steel	12
19	Body Nut	S. Steel	12
20	Anti-Static Spring	S. Steel	3
21	Anti-Static Plunger	S. Steel	3
23	Tag (not shown)	S. Steel	1

* Maintenance kit components

Face To Face Sizes

Valve Size	Unit	B		A-XBW / ETI / ETD / GR		A-ETO		A-Flanged CLASS 150+300		A-Flanged CLASS 600		A-Flanged DIN		A-TC
		Std. port	Full port	Std. port	Full port	Std. port	Full port	Std. port	Full port	Std. port	Full port	Std. port	Full port	Full port
DN10	mm	93.2	93.2	213.2	215.6	181.2								
3/8"	inch	3.7	3.7	8.4	8.5	7.1								
DN15	mm	93.2	107.2	213.2	229.6	209.6	212.6	222.6	237.6	222.6	202.6	212.6	161.4	
1/2"	inch	3.7	4.2	8.4	9.0	8.3	8.4	8.7	9.4	8.7	8.0	8.3	6.4	
DN20	mm	107.2	132.2	229.6	269.2	229.6	234.6	252.5	234.6	252.5	232.6	250.5	184.2	
3/4"	inch	4.2	5.2	9.0	10.6	9.0	9.2	9.9	9.2	9.9	9.1	9.9	7.3	
DN25	mm	132.2	142.2	269.2	280.2	264.6	265.5	265.9	316.5	265.9	260.5	260.9	214.8	
1"	inch	5.2	5.6	10.6	11.0	10.4	10.4	10.5	12.5	10.5	10.3	10.3	8.5	
DN32	mm	142.2	176.2	280.2	317.2	280.2	278.9	305.8	278.9	305.8	280.9	307.8		
1 1/4"	inch	5.6	6.9	11.0	12.5	11.0	11.0	12.0	11.0	12.0	11.1	12.1		
DN40	mm	176.2	184.2	317.2	328.2	311.8	317.8	317.9	368.8	317.9	327.8	327.9	267.6	
1 1/2"	inch	6.9	7.3	12.5	12.9	12.3	12.5	12.6	14.5	12.6	12.9	13.0	10.5	
DN50	mm	184.2	229.2	328.2	389.2	321.4	343.9	372.6	419.8	372.6	357.9	386.6	286.8	
2"	inch	7.3	9.0	12.9	15.3	12.7	13.6	14.6	16.5	14.6	14.1	15.2	11.3	
DN65	mm	229.2		389.2		379.2	397.6		397.6		446.6		369.6	
2 1/2"	inch	9.0		15.3		14.9	15.6		15.6		17.6		14.6	

XBW / ETO / ETI / ETD / GR

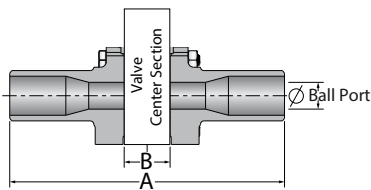

Flanged

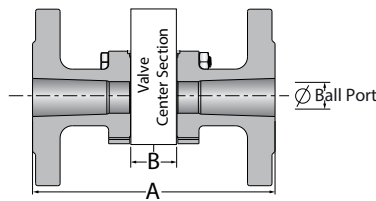

TC

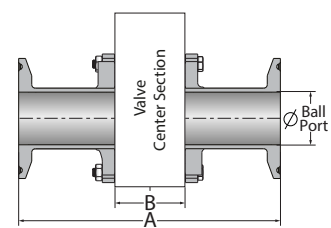
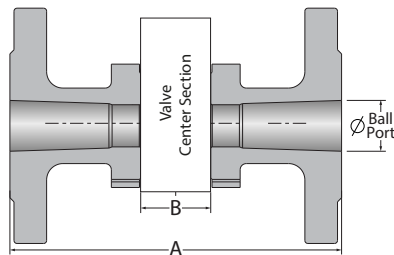
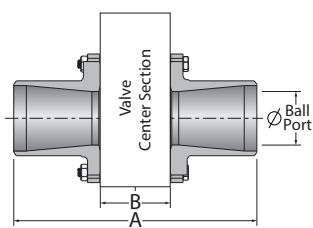
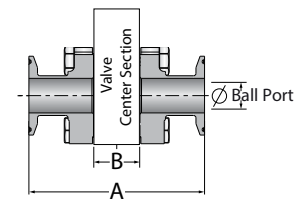



Dual Safe | Double Block & Bleed - Ordering Code System

"Mandatory option" options are marked with **green background** | "Standard offer" options are marked with **light green background**

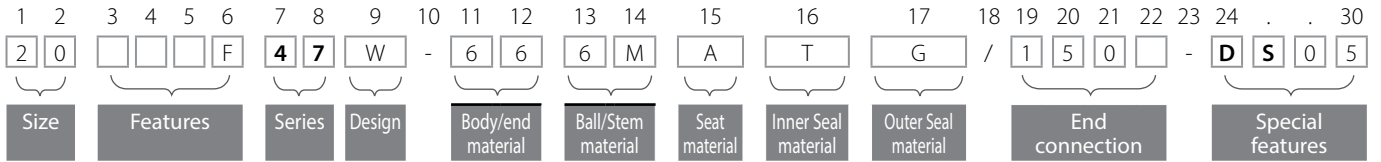

Size (1-2)		
Code	inch	mm
05	½"	15
07	¾"	20
10	1"	25
12	1¼"	32
15	1½"	40
20	2"	50
25*	2½"	65

* Std. port only

Features (3-6)	
F	Fire safe
B	Full port
H*	Hydrogen service

* for material selection - see Hydrogen Service chapter

Series (7-8)	
47	Floating ball 3 piece

Design (9)	
W	Total HermetiX Integrity package
G	Total HermetiX Integrity package - FDA compliant

Body material (11)	
6	S. Steel
4	C. steel A216 WCB/ A105

End material(12)	
6	S. Steel
4	C. steel A216 WCB/ A105

Ball material (13)	
6	S. Steel 316
M	High Strength S. Steel

Stem material (14)	
M	High Strength S. Steel
6	S. Steel

Seat material (15)	
A	TFM
U	UHMWPE
T	PTFE
P	CF PTFE
C	PCTFE
K	CF PEEK
L	Virgin Peek
Y	Delrin
W	PVDF
R	15% Glass filled PTFE

Inner Seal Material (16)	
T	PTFE
A	TFM
U	UHMWPE
V	Viton
B	NBR
G	Expanded graphite

Outer Seal (17)	
G	Expanded graphite
A	TFM

End Connection (19-22)	
Welded	
BW10	Buttweld schd. 10
BW	Buttweld schd. 40
SW	Socket weld
XBW10	Extended buttweld schd. 10
XBW	Extended buttweld schd. 40
XSW	Extended socket weld
BW5	Buttweld schd. 5
BW80	Buttweld schd. 80
BWO*	Buttweld tube OD
BWD	Buttweld DIN 11850
BW1.6	buttweld ISO 1127 1.6mm
BW2.0	buttweld ISO 1127 2.0mm
BW12.3	buttweld ISO 1127 2.3mm
SWO*	Socket weld tube OD
ETO*	Extended tube OD
ETI1.6	Extended buttweld ISO 1127 1.6mm
ETI2.0	Extended buttweld ISO 1127 2.0mm
ETI2.3	Extended buttweld ISO 1127 2.3mm
ETD	Extended buttweld DIN 11850

Threaded	
NPT	ASME B1.20.1 - National Pipe Taper thread
BSPT	EN 10226 - Pipe Taper thread
BSPP	ISO228-1, DIN3852 - Pipe Parallel thread
DIN3852	DIN3852 - Pipe Parallel thread
AS5202	SAE internal straight thread
MNPT	Male NPT
MBSPT	Male BSPT

Flanged	
150	ASME B16.5 #150 RF
300	ASME B16.5 #300 RF
600	ASME B16.5 #600 RF
900	ASME B16.5 #900 RF
PN16	EN1092 PN16 RF
PN40	EN1092 PN40 RF
PN63	EN1092 PN63 RF
PN100	EN1092 PN100 RF
PN160	EN1092 PN160 RF

Clamp	
LL*	Compression fitting (Imperial) - No Nuts & Ferrules
LM*	Compression fitting (metric) - No Nuts & Ferrules
LL-NF*	Compression fitting (Imperial) - with Nuts & Ferrules
LM-NF*	Compression fitting (metric) - with Nuts & Ferrules
TC*	Tri-Clamp
GR**	Grayloc® compatible hub (Grayloc® is a registered trademark of Grayloc Products, L.L.C.)

Special Features (24-30)	
Dual Safe Features	
DS	Dual Safe with Ball Valve Bleed
DSN	Dual Safe with Needle Valve Bleed
Bleed Connection Size	
05	½" (DN15)
02	¼" (DN8)
03	¾" (DN10)
Bleed Connection	
Blank	The same as the line connection
N	NPT
D	DIN3852
B	BSPT
BW	BW

* Std. port only

** Not available for 1¼" (DN32) Valves

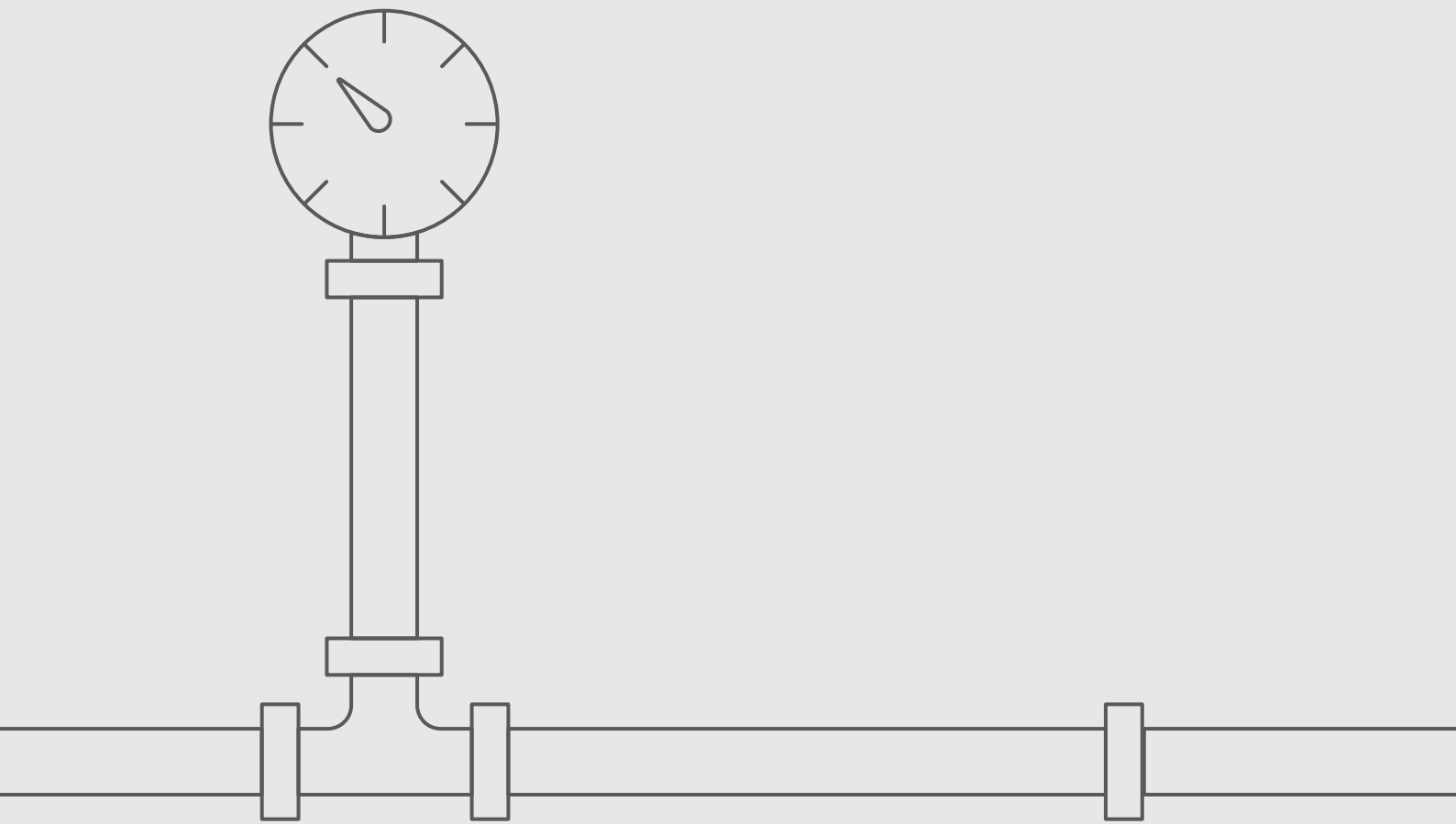

73DS

74DS

77DS

78DS



Industrial Valves

FLOATING BALL

DUAL SAFE /
DOUBLE BLOCK & BLEED
FLANGED

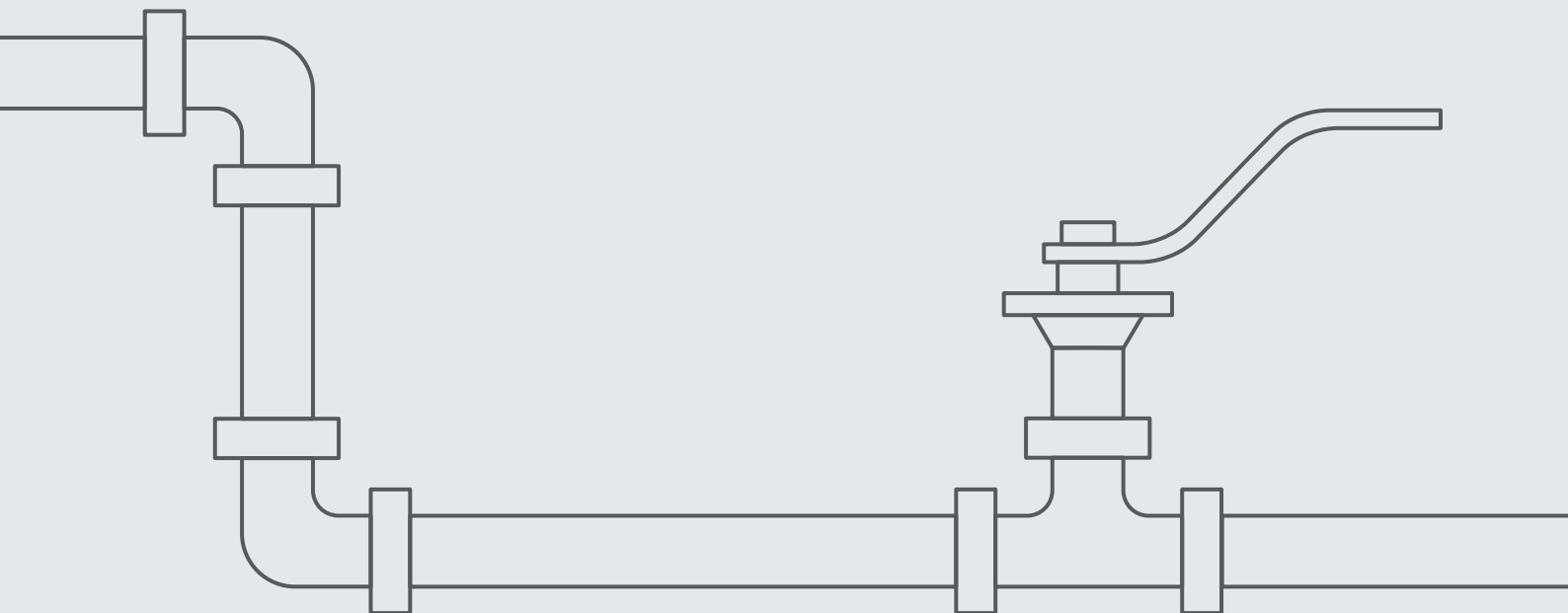

73DS

74DS

77DS

78DS

2 1/2"-6" | DN65-DN150
CLASS 150/300/PN 16

Dual Safe | Double Block & Bleed Floating Ball Flanged

Valve Dimensions

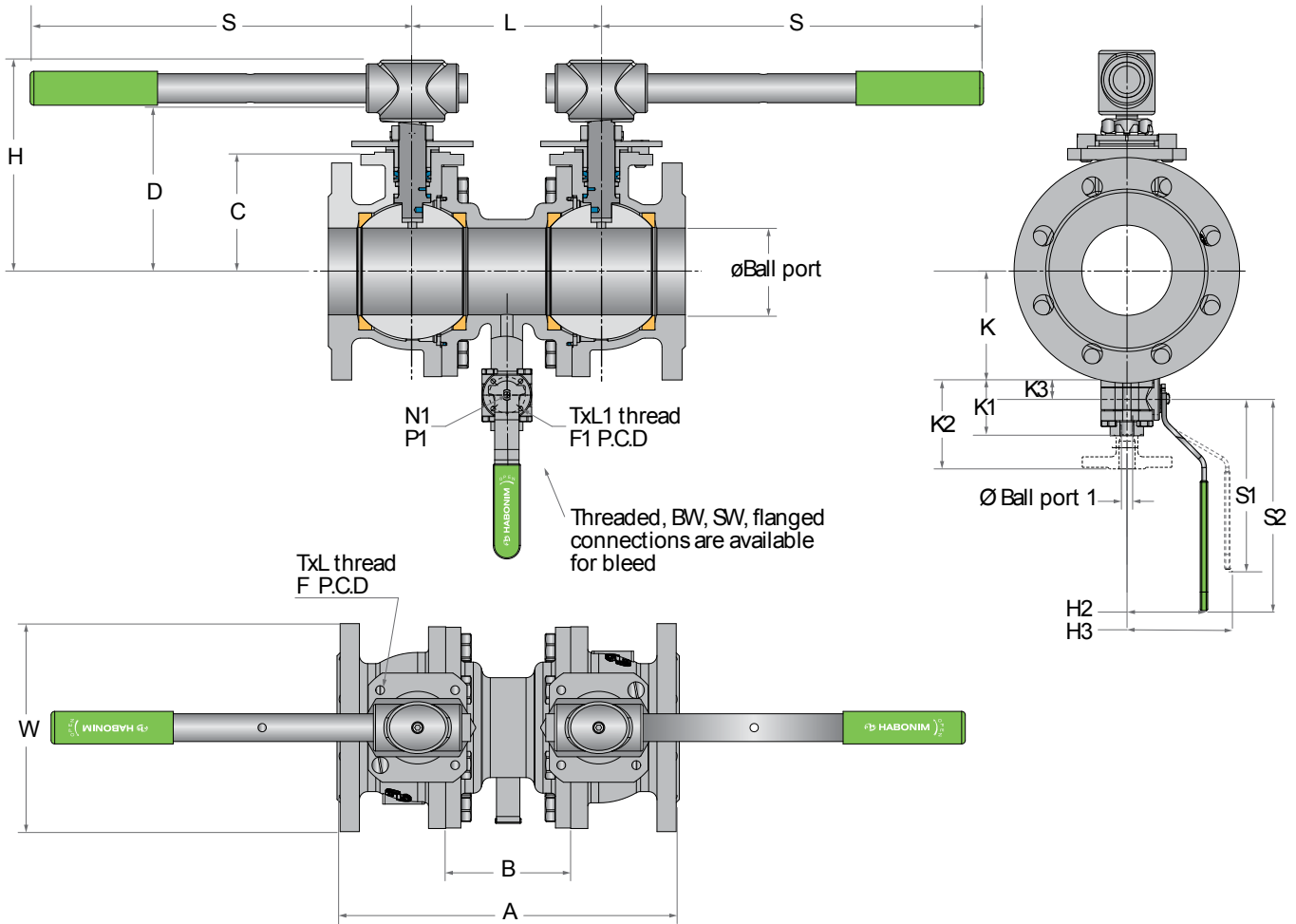

Bore dimensions

Full port	Unit	Ball Port	A			B	C_73/74	D_73/74	H	K	L	S	W		W_16/40	N	P	F	TxL	Kv	
			150	300	PN								150	300							
DN65	mm	65.0	375	400.5	349.0	155.0	119.0	165.5	184.5	90.0	209.0	288.1	180.0	190.0	185.0	1"-14	16.7	F10	102.0	M10X20	6.9
2 1/2"	inch	2.55	14.71	15.71	13.69	6.08	4.67	6.49	7.24	3.53	8.2	11.30	7.08	7.48	7.28	UNF-2A"	0.65	F10	4.0	M10X20	8
DN80	mm	80.0	369	406.8	369.0	160.0	108.0	154.5	194.9	95.0	214.0	350.0	191.0	210.0	200.0	1"-14	16.7	F10	102.0	M10X20	10
3"	inch	3.14	14.47	15.95	14.47	6.27	4.24	6.06	7.64	3.73	8.39	13.73	7.52	8.27	7.87	UNF-2A"	0.65	F10	4.0	M10X20	12
DN100	mm	100.0	442.0	482.0	442.0	215.0	124.0	170.5	210.9	115.0	273.0	350.0	230.0	254	225.0	1"-14	16.7	F10	102.0	M10X20	28
4"	inch	3.92	17.33	18.9	17.33	8.43	4.86	6.69	8.27	4.51	10.71	13.73	9.06	10.0	8.86	UNF-2A"	0.65	F10	4.0	M10X20	32
DN150	mm	150.0	681.0	703.2	681.0	280.0	179.0	248.4	302.2	165.0	354.0	846.5	279.4	328.0	328.0	1 1/2"-12	26.2	F12	125.0	M16X30	49
6"	inch	5.88	26.71	27.58	26.71	10.98	7.02	9.74	11.85	6.47	13.88	33.20	11.0	12.91	12.91	UNF-1A"	1.03	F12	4.90	M16X30	57

Bleed dimensions

Full port	Unit	Ball Port 1	K1	K2	K3	S1	S2	H2	H3	N1	P1	F1	TxL
DN20	mm	17.5	57.15	98.15	21.9	114.5	152.5	93.0	49.0	3/8" UNF	6.65	F03	36.0
3/4"	inch	0.69	2.24	3.85	0.86	4.51	6.0	3.66	1.93	3/8" UNF	0.26	F03	1.41
DN25	mm	23.5	74.85	110.75	28.2	146.0	163.0	106.0	62.0	7/16" UNF	7.4	F04	42.0
1"	inch	0.92	2.94	4.34	1.11	5.75	6.42	4.17	2.44	7/16" UNF	0.29	F04	1.65

73DS

74DS

77DS

78DS

2 1/2"-6" | DN65-DN150
CLASS 150/300/PN 16

Dual Safe | Double Block & Bleed Floating Ball Flanged

Components & Materials

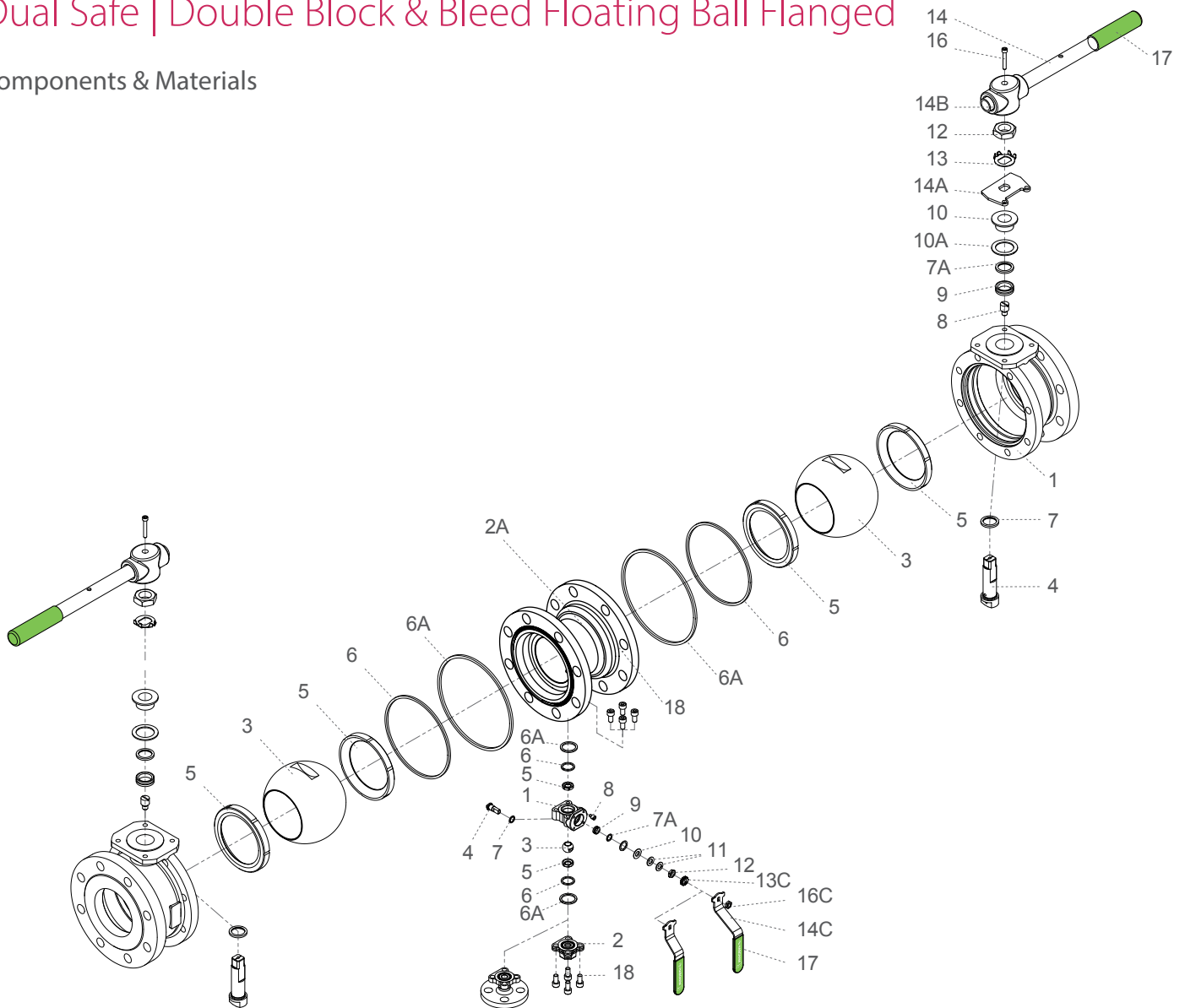

Item	Description	Material specifications	Qty.
1	Body	Acc. Ordering Code	3
2	Ends	Acc. Ordering Code	1
2A	Connection Spool	Acc. Ordering Code	1
3	Ball	Acc. Ordering Code	3
4	Stem	Acc. Ordering Code	3
5*	Seat	Acc. Ordering Code	6
6*	Body Seal	Acc. Ordering Code	4
6A*	Outer Seal	Acc. Ordering Code	4
7*	Stem Thrust Seal	PEEK, CF PEEK, PCTFE	3
7A*	Anti-Abrasion Ring	PEEK, CF PEEK, PCTFE	3
8	Stop Pin	S. Steel	3
9*	Stem Seal	CF PTFE, TFM, Graphite	3
10	Follower	S. Steel	3
10A*	Slide Bearing	TF316	3
11	Disc Spring	S. Steel	2

Item	Description	Material specifications	Qty.
12	Stem Nut	S. Steel	3
13	Tab Lock Washer	S. Steel	2
13C	Locking Clip	S. Steel	1
14	Handle	S. Steel	2
14C	Handle	S. Steel	1
14A	Stop Plate	S. Steel	2
14B	Wrench Head	S. Steel	2
16	Wrench Bolt	S. Steel	2
16C	Handle Nut	S. Steel	1
17	Sleeve	PVC	3
18	Body Bolt	S. Steel	24-32
20	Anti-Static Spring	S. Steel	3
21	Anti-Static Plunger	S. Steel	3
23	Tag (not shown)	S. Steel	1

* Maintenance kit components

73DS

74DS

77DS

78DS



Dual Safe | Double Block & Bleed - Ordering Code System

"Mandatory option" options are marked with **green background** | "Standard offer" options are marked with **light green background**

1	2	3	4	5	6	7	8	9	10	11	12	13	14	15	16	17	18	19	20	21	22	23	24	.	.	30
6	0			F	B	7	3	W	-	6	6	6	M	A	T	G	/	1	5	0		-	D	S	1	0
Size		Features				Series		Design		Body/end material		Ball/Stem material		Seat material	Inner Seal material	Outer Seal material	End connection					Special features				

Size (1-2)		
Code	inch	mm
25	2½"	65
30	3"	80
40	4"	100
60	6"	150

Features (3-6)	
B	Full port
F	Fire safe
H*	Hydrogen service

* for material selection - see Hydrogen Service chapter

Series (7-8)	
73	ANSI #150 full port
74	ANSI #300 full port
77	DIN PN 16 full port
78	DIN PN 40 full port

Design (9)	
W	Total HermetiX Integrity package
G	Total HermetiX Integrity package - FDA compliant

Body material (11)	
6	S. Steel
4	C. steel A216 WCB/A105

End material (12)	
6	S. Steel
4	C. steel A216 WCB/A105

Ball material (13)	
6	S. Steel 316
M	High Strength S. Steel

Stem material (14)	
M	High Strength S. Steel
6	S. Steel

Seat material (15)	
A	TFM
U	UHMWPE
T	PTFE
P	CF PTFE
C	PCTFE
K	CF PEEK
L	Virgin Peek
Y	Delrin
W	PVDF
R	15% Glass filled PTFE

Inner Seal Material (16)	
T	PTFE
A	TFM
U	UHMWPE
V	Viton
B	NBR
G	Expanded graphite

Outer Seal (17)	
G	Expanded graphite
A	TFM

End Connection (19-22)	
Welded ends	
150	ASME B16.5 #150 RF
300	ASME B16.5 #300 RF
PN16	EN1092 PN16 RF

Special Features (24-30)	
Dual Safe Features	
DS	Dual Safe with Ball Valve Bleed
DSN	Dual Safe with Needle Valve Bleed
Bleed Connection Size	
10	1" (DN25)
07	¾" (DN20)
Bleed Connection	
Blank	The same as the line connection
N	NPT
D	DIN3852
B	BSPT
BW	BW

61

62

D61

D62



Industrial Valves

FLOATING BALL

MULTIPOINT

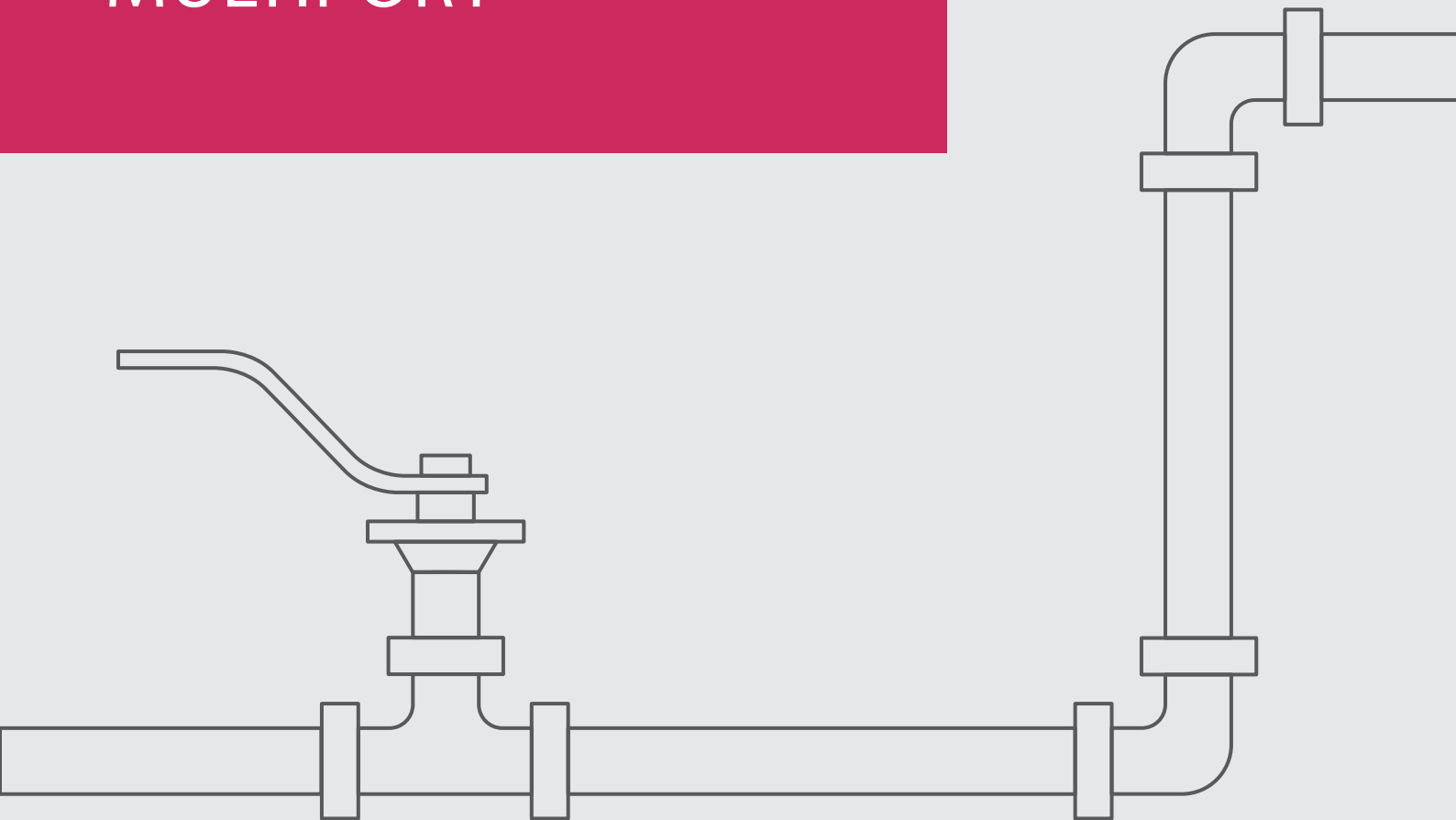

Multiport Floating Ball

Valve Dimensions

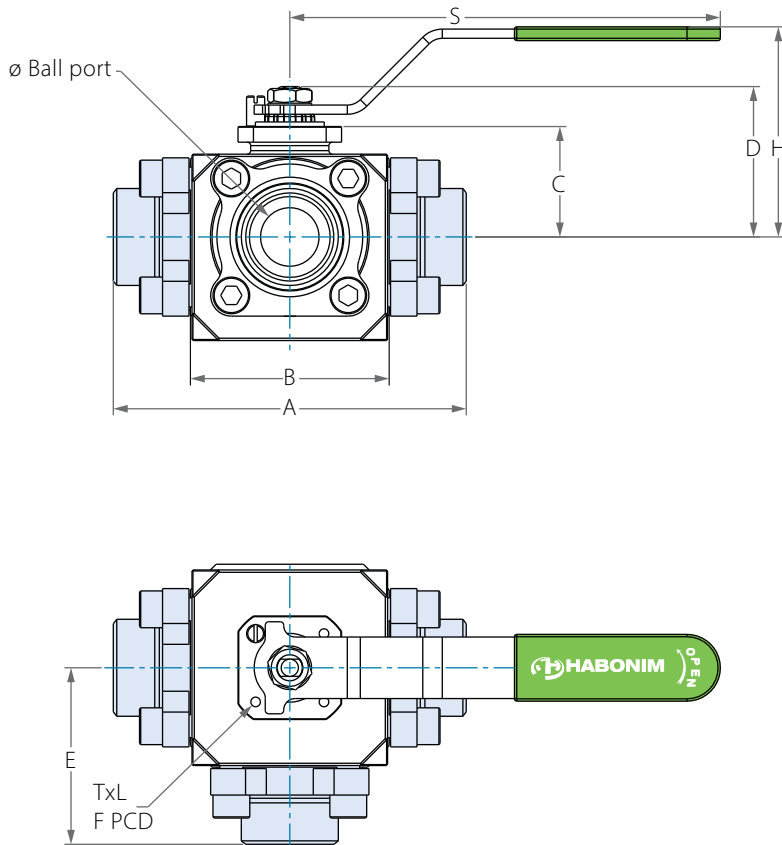

Preparation for actuation

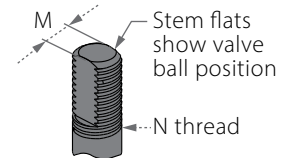
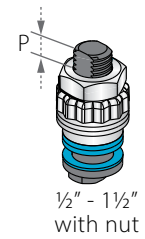

Valve Face To Face sizes are according to Habonim catalog data only, for Extended-weld/Flanged/Tri-clamp end see Face To Face sizes page.

Std. port	Full port	Unit	Ball port	A	B	C	D	E	H	S	M	N	P	TxL	F	PCD	Weight kg/lb
DN20	DN15	mm	14.3	113.0	67.0	38.1	55.6	A/2	80.0	187.0	7.54	7/16"	5.8	M5X8	F04	42.0	2.8
3/4"	1/2"	inch	0.56	4.45	2.64	1.50	2.19		3.15	7.36	0.30	UNF	0.23				1.65
DN25	DN20	mm	20.6	143.6	81.6	43.0	60.5		85.5	187	7.54	7/16"	5.8	M5X8	F04	42.0	4.3
1"	3/4"	inch	0.81	5.65	3.21	1.69	2.38		3.37	7.36	0.30	UNF	0.23				1.65
DN32	DN25	mm	25.4	153.4	86.4	48.0	65.5		90.0	187.0	7.54	7/16"	5.8	M5X8	F04	42.0	6.0
1 1/4"	1"	inch	1.0	6.04	3.40	1.89	2.58		3.54	7.36	0.30	UNF	0.23				1.65
DN40	DN32	mm	31.8	164.0	97.0	49.4	78.9	103.0	237.0	8.71	9/16"	7.8	M6X9	F05	50.0	7.5	
1 1/2"	1 1/4"	inch	1.25	6.46	3.82	1.94	3.11	4.06	9.33	0.34	UNF	0.31				1.97	16.5

Valve Size		Flow Coefficients	
mm	inch	KV	CV
DN20	3/4"	9	11
DN25	1"	27	31
DN32	1 1/4"	47	55
DN40	1 1/2"	67	78



Multiport Floating Ball

Components & Materials

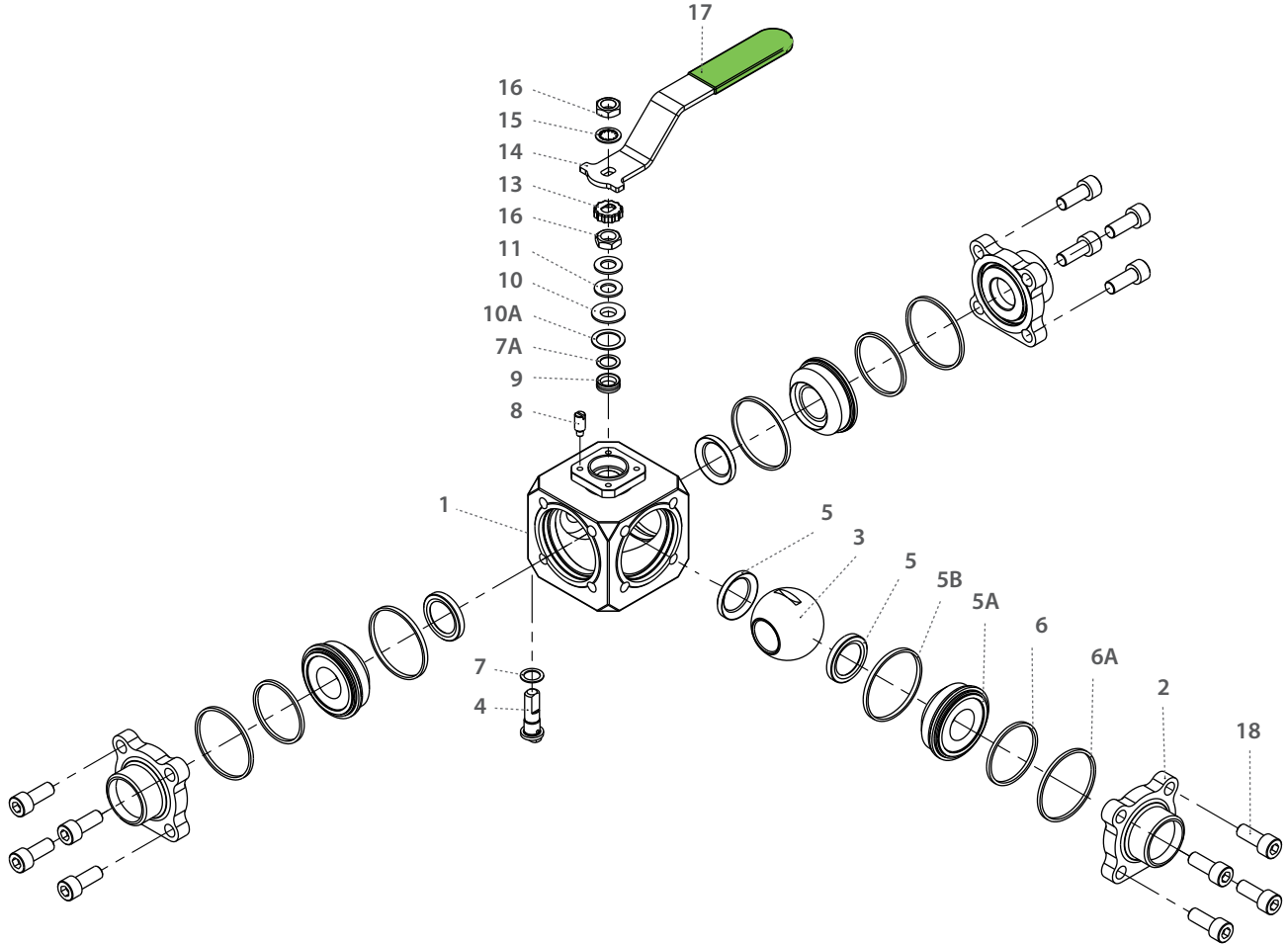

Item	Description	Material specification	Qty.
1	Body	Acc. Ordering Code	1
2	Ends	Acc. Ordering Code	5
3	Ball	Acc. Ordering Code	1
4	Stem	Acc. Ordering Code	1
5*	Seat	Acc. Ordering Code	4
5A	Support Seat	See body material	4
5B*	Seat Seal	Acc. Ordering Code	4
6*	Inner Seal	Acc. Ordering Code	5
6A*	Outer Seal	Acc. Ordering Code	5
7*	Stem Thrust Seal	PEEK, CF PEEK, PCTFE	1
7A*	Anti-Abrasion Ring	PEEK, CF PEEK, PCTFE	1
8	Stop Pin	S. Steel	1

Item	Description	Material specification	Qty.
9*	Stem Seal	CF PTFE,TFM	1
10	Follower	S. Steel	1
10A*	Slide Braring	S. Steel	1
11	Disc Spring	S. Steel	2
12	Stem Nut	S. Steel	1
13	Locking Clip	S. Steel	1
14	Handle	S. Steel	1
15	Serrated Washer	S. Steel	1
16	Handle Nut	S. Steel	1
17	Sleeve	PVC	1
18	Body Bolts	S. Steel	12

* Maintenance kit components

Multiport Floating Ball

Valve Dimensions

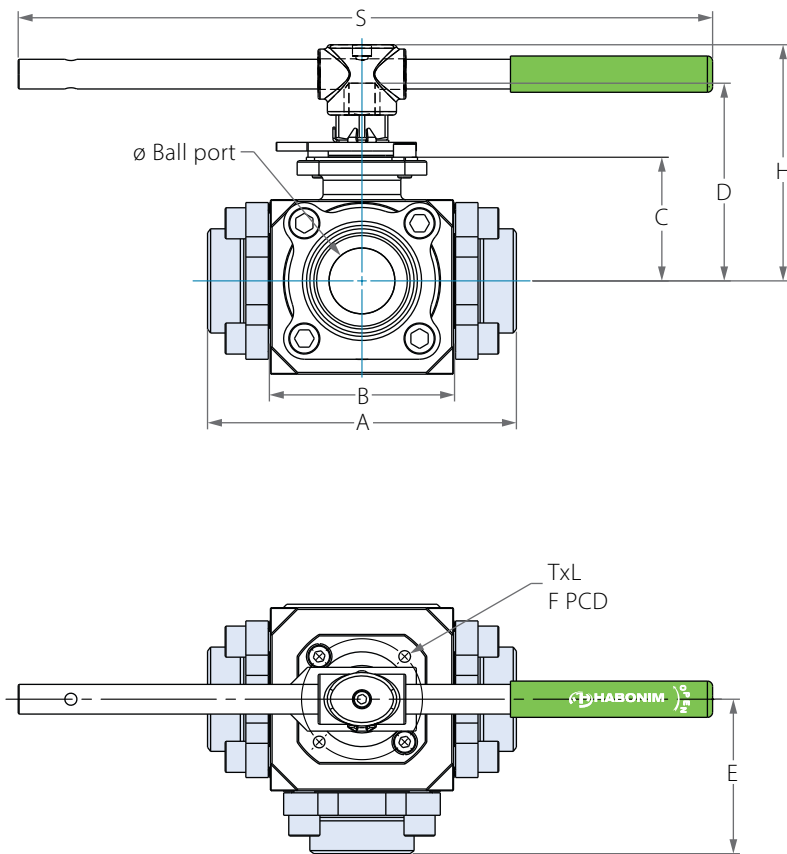

Preparation for actuation

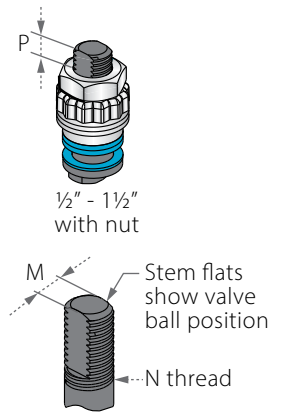

Valve Face To Face sizes are according to Habonim catalog data only, for Extended-weld/Flanged/Tri-clamp end see Face To Face sizes page.

Std. port	Full port	Ball port	A	B	C	D	E	H	S	M	N	P	TxL	PCD	Weight kg/lb	Kv Cv
DN50	DN40	38.1	177.2	107.2	69.7	111.3	A/2	140.0	400.0	13.9	M20x2.5	13.5	F07	70.0	11	102
2"	1½"	1.50	6.98	4.22	2.74	4.38		5.51	15.75	0.55		0.53		2.76	24.2	118
DN65	DN50	48.0	210.4	125.0	79.1	120.7		150.0	400.0	13.9	M20x2.5	13.5	F07	70.0	16.5	208
2½"	2"	1.89	8.28	4.92	3.11	4.75		5.91	15.75	0.55		0.53		2.76	36.3	241



Multiport Floating Ball

Components & Materials

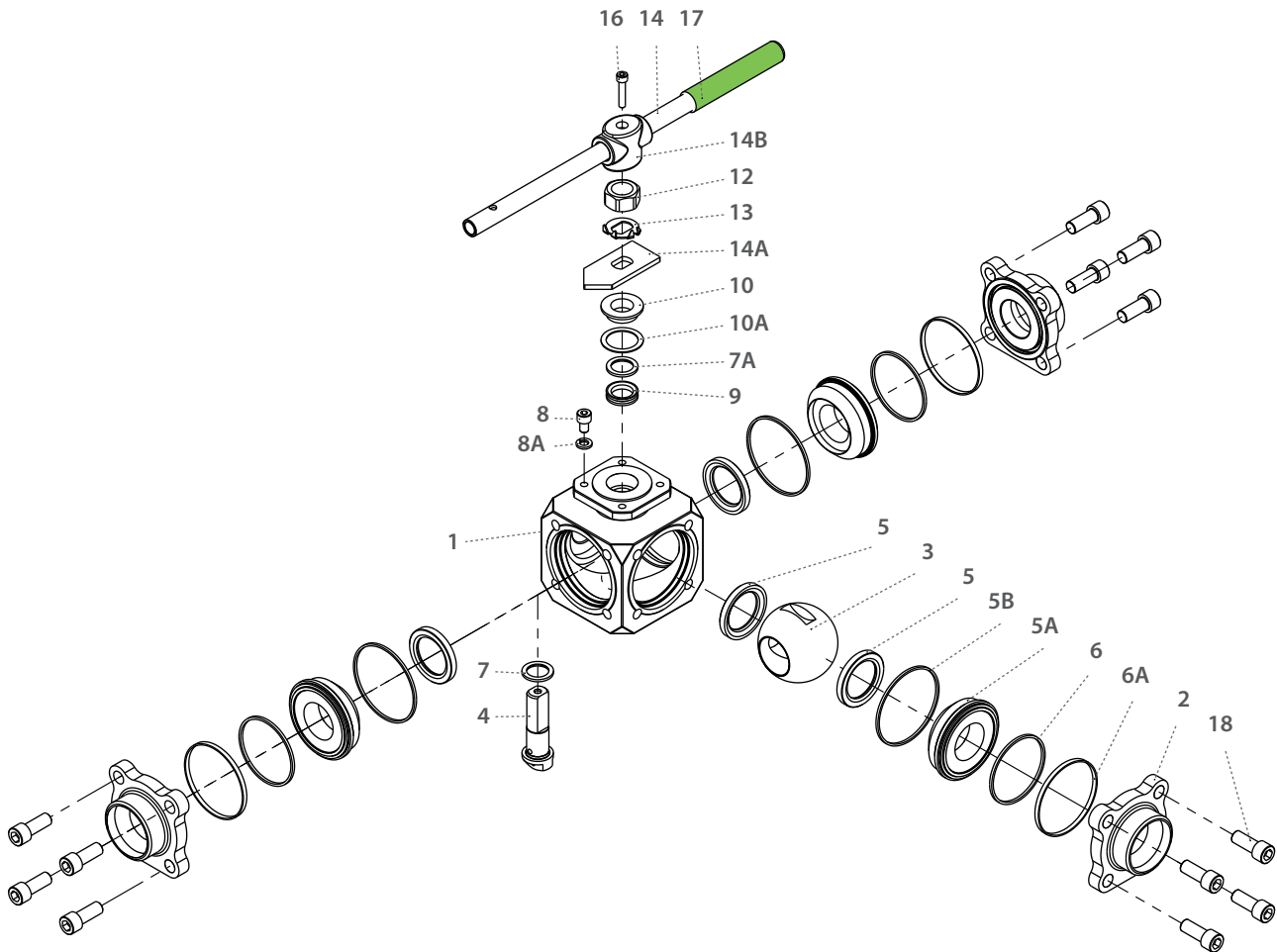

Item	Description	Material specification	Qty.
1	Body	Acc. Ordering Code	1
2	Ends	Acc. Ordering Code	5
3	Ball	Acc. Ordering Code	1
4	Stem	Acc. Ordering Code	1
5*	Seat	Acc. Ordering Code	4
5A	Support Seat	Acc. Ordering Code	4
5B*	Seat Seal	Acc. Ordering Code	4
6*	Inner Seal	Acc. Ordering Code	5
6A*	Outer Seal	Acc. Ordering Code	5
7*	Stem Thrust Seal	V. PEEK, CF PEEK, PCTFE	1
7A*	Anti-Abrasion Ring	V. PEEK, CF PEEK, PCTFE	1
8	Stop Pin	S. Steel	1

Item	Description	Material specification	Qty.
8A	Spring Washer	S. Steel	1
9*	Stem Seal	CF PTFE,TFM	1
10	Follower	S. Steel	1
10A*	Slide Braring	S. Steel	1
12	Stem Nut	S. Steel	1
13	Locking Clip	S. Steel	1
14	Handle	S. Steel	1
14A	Stop Plate	S. Steel	1
14B	Wrench Bolt	S. Steel	1
16	Handle Nut	S. Steel	1
17	Sleeve	PVC	1
18	Body Bolts	S. Steel	12

* Maintenance kit components

Multiport Floating Ball

Valve Dimensions

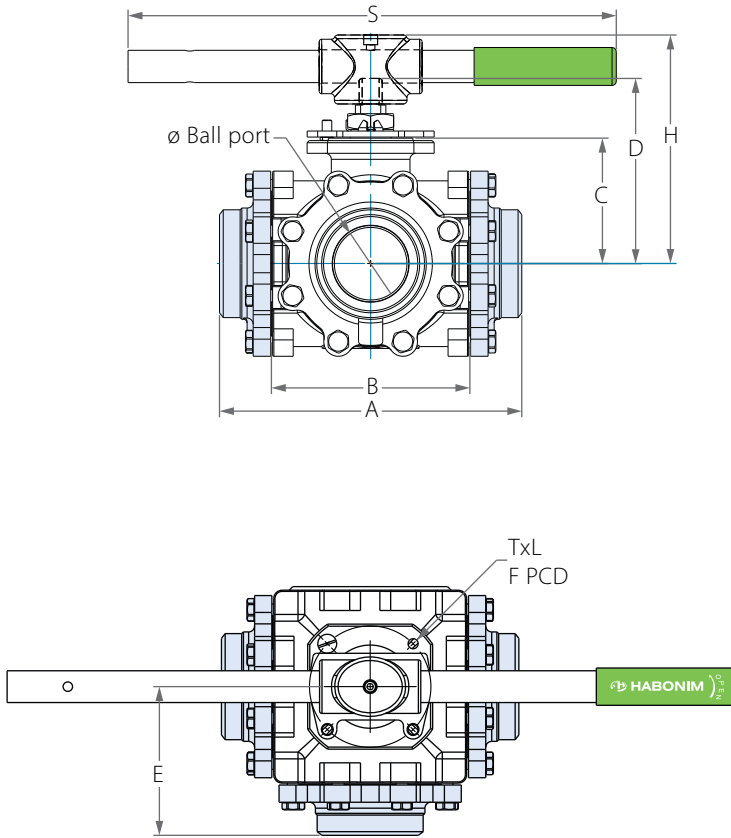

Preparation for actuation

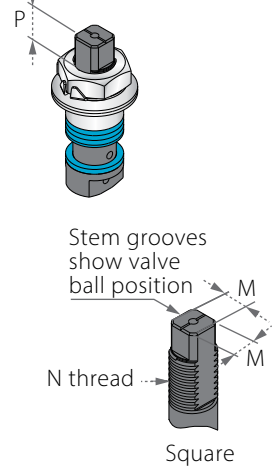

Valve Face To Face sizes are according to Habonim catalog data only, for Extended-weld/Flanged/Tri-clamp end see Face To Face sizes page.

Std. port	Unit	Ball port	A	B	C	D	E	H	M	M-DD	N	P	TxL	F	S	Weight kg/lb
DN80	mm	60.0	249.80	164.0	101.75	143.35	A/2	189.0	18.90	15.90	1"-14	16.70	M10x11	F10	610.0	40
3"	inch	2.36	9.83	6.45	4.01	5.64		7.44	0.74	0.63	UNS-2A	0.66			24.02	88.00
DN100	mm	76.0	309.80	205.0	134.50	203.60	A/2	264.0	28.45	23.75	1"-14	26.20	M12x14	F12	920.0	55
4"	inch	2.99	12.19	8.07	5.30	8.02		10.39	1.12	0.93	UNS-2A	1.03			36.22	121

Valve Size		Flow Coefficients	
mm	inch	KV	CV
DN80	3"	267	310
DN100	4"	484	562



Multiport Floating Ball

Components & Materials

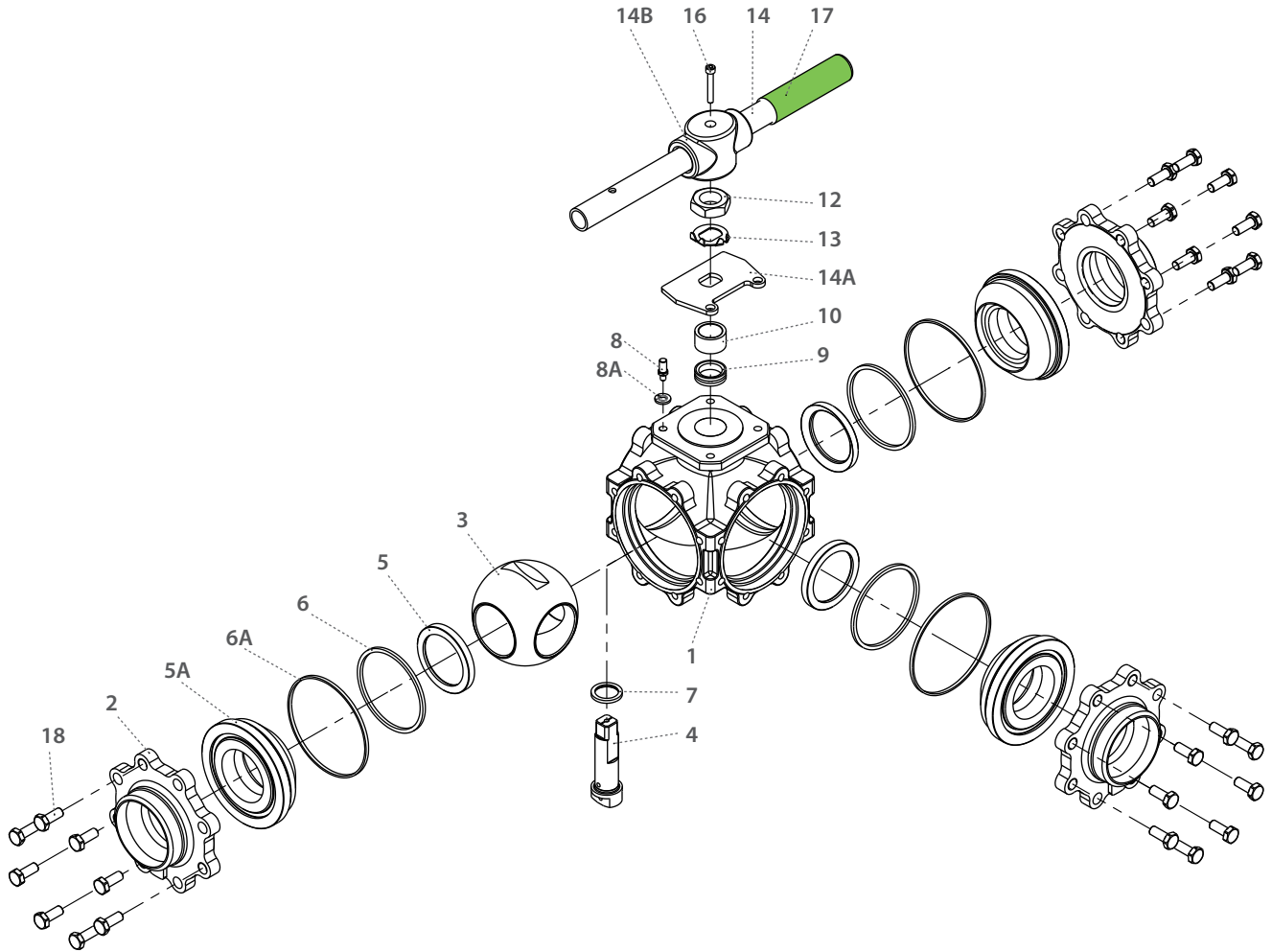

Item	Description	Material specification	Qty.
1	Body	Acc. Ordering Code	1
2	Ends	Acc. Ordering Code	4
3	Ball	Acc. Ordering Code	1
4	Stem	Acc. Ordering Code	1
5*	Seat	Acc. Ordering Code	4
5A	Support Seat	Acc. Ordering Code	4
6*	Seat Seal	Acc. Ordering Code	4
6A*	Body Seal	Acc. Ordering Code	5
7*	Stem Thrust Seal	PEEK, CF PEEK, PCTFE	1
8	Stop Bolts	S. Steel	1
8A	Spring Washer	S. Steel	1

Item	Description	Material specification	Qty.
9*	Stem Seal	CF PTFE,TFM	1
10	Follower	S. Steel	1
12	Stem Nut	S. Steel	1
13	Tab Lock Washer	S. Steel	1
14	Wrench Handle	C.St. Zinc Plate	1
14A	Stop Plate	S. Steel	1
14B	Wrench Head	S. Steel	1
16	Wrench Bolt	S. Steel	1
17	Sleeve	PVC	1
18	Body Bolt	S. Steel	24
23	Tag (not shown)	S. Steel	1

* Maintenance kit components

Multiport Floating Ball

Valve Dimensions

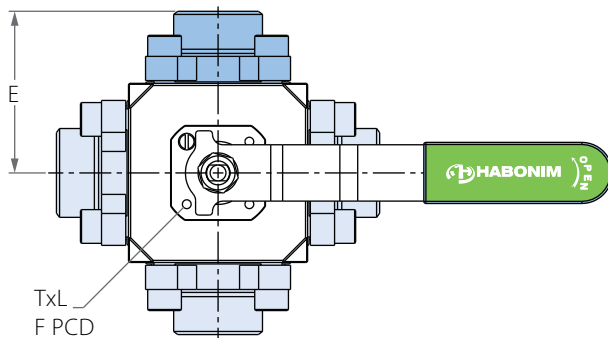
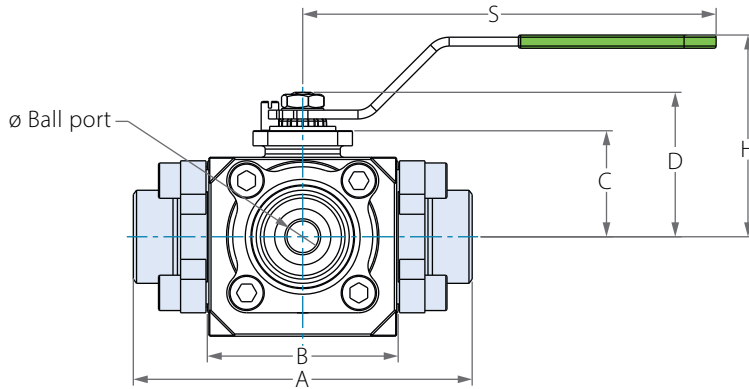

Preparation for actuation

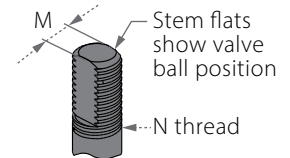
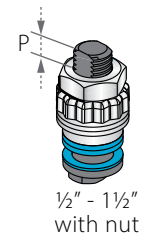

Valve Face To Face sizes are according to Habonim catalog data only, for Extended-weld/Flanged/Tri-clamp end see Face To Face sizes page.

Std. port	Full port	Unit	Ball port	A	B	C	D	E	H	S	M	N	P	TxL	F	PCD	Weight kg/lb
DN20	DN15	mm	14.3	113.0	67.0	38.1	55.6	A/2	80.0	187.0	7.54	7/16"	5.8	M5X8	F04	42.0	2.8
3/4"	1/2"	inch	0.56	4.45	2.64	1.50	2.19		3.15	7.36	0.30	UNF	0.23				1.65
DN25	DN20	mm	20.6	143.6	81.6	43.0	60.5	A/2	85.5	187.0	7.54	7/16"	5.8	M5X8	F04	42.0	4.3
1"	3/4"	inch	0.81	5.65	3.21	1.69	2.38		3.37	7.36	0.30	UNF	0.23				1.65
DN32	DN25	mm	25.4	153.4	86.4	48.0	65.5	A/2	90.0	187.0	7.54	7/16"	5.8	M5X8	F04	42.0	6
1 1/4"	1"	inch	1.0	6.04	3.40	1.89	2.58		3.54	7.36	0.30	UNF	0.23				1.65
DN40	DN32	mm	31.8	164.0	97.0	49.4	78.9	A/2	103.0	237.0	8.71	9/16"	7.8	M6X9	F05	50.0	7.5
1 1/2"	1 1/4"	inch	1.25	6.46	3.82	1.94	3.11		4.06	9.33	0.34	UNF	0.31				1.97

Valve Size		Flow Coefficients	
mm	inch	KV	CV
DN20	3/4"	9	11
DN25	1"	27	31
DN32	1 1/4"	47	55
DN40	1 1/2"	67	78



Multiport Floating Ball

Components & Materials

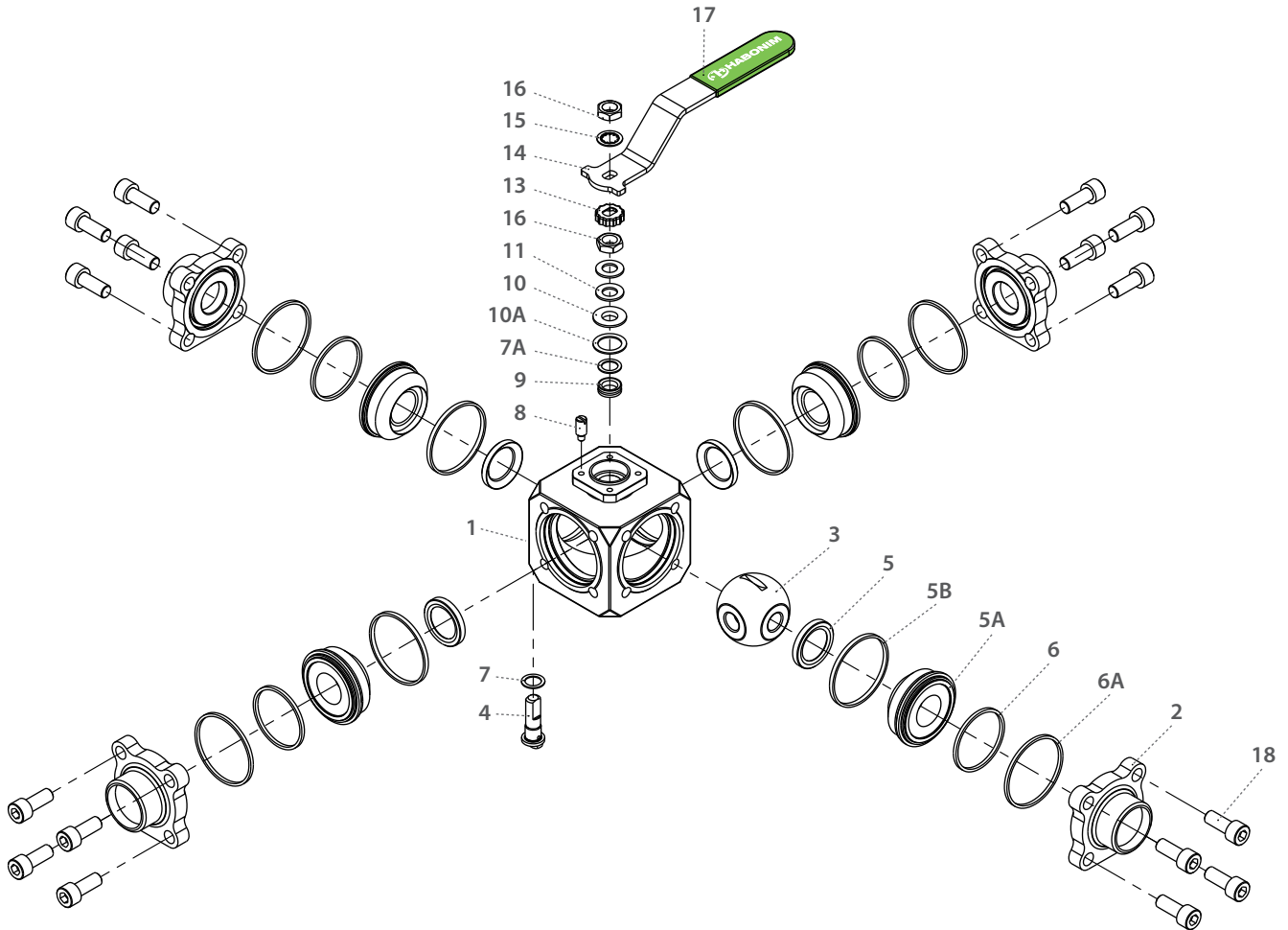

Item	Description	Material specification	Qty.
1	Body	Acc. Ordering Code	1
2	Ends	Acc. Ordering Code	5
3	Ball	Acc. Ordering Code	1
4	Stem	Acc. Ordering Code	1
5*	Seat	Acc. Ordering Code	4
5A	Support Seat	See body material	4
5B*	Seat Seal	Acc. Ordering Code	4
6*	Inner Seal	Acc. Ordering Code	5
6A	Outer Seal	Acc. Ordering Code	5
7*	Stem Thrust Seal	PEEK, CF PEEK, PCTFE	1
7A*	Anti-Abrasion Ring	PEEK, CF PEEK, PCTFE	1
8	Stop Pin	S. Steel	1

Item	Description	Material specification	Qty.
9*	Stem Seal	CF PTFE,TFM	1
10	Follower	S. Steel	1
10A	Slide Braring	S. Steel	1
11	Disc Spring	S. Steel	2
12	Stem Nut	S. Steel	1
13	Locking Clip	S. Steel	1
14	Handle	S. Steel	1
15	Serrated Washer	S. Steel	1
16	Handle Nut	S. Steel	1
17	Sleeve	PVC	1
18	Body Bolts	S. Steel	16

* Maintenance kit components

Multiport Floating Ball

Valve Dimensions

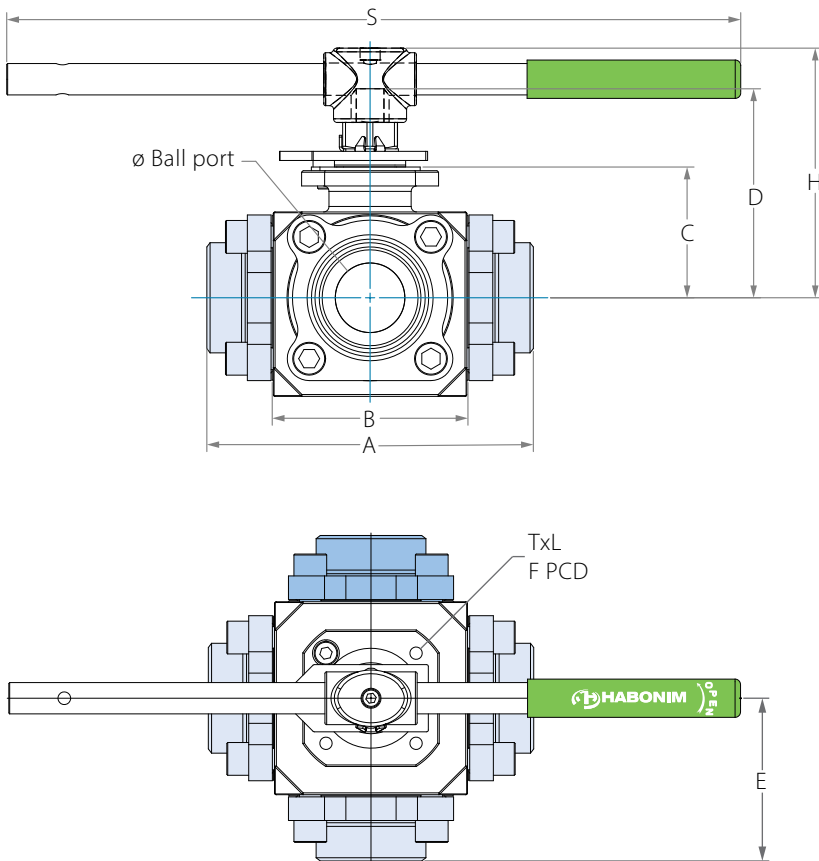

Preparation for actuation

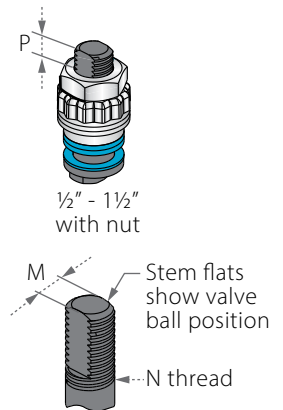

Valve Face To Face sizes are according to Habonim catalog data only, for Extended-weld/Flanged/Tri-clamp end see Face To Face sizes page.

Std. port	Full port	Ball port	A	B	C	D	E	H	S	M	N	P	TxL	PCD	Weight kg/lb	Kv Cv
DN50	DN40	38.1	177.2	107.2	69.7	111.3	A/2	140.0	400.0	13.9	M20x2.5	13.5	F07	70.0	11	102
2"	1½"	1.50	6.98	4.22	2.74	4.38		5.51	15.75	0.55		0.53		2.76	24.2	118
DN65	DN50	48.0	210.4	125.0	79.1	120.7		150.0	400.0	13.9	M20x2.5	13.5	F07	70.0	16.5	208
2½"	2"	1.89	8.28	4.92	3.11	4.75		5.91	15.75	0.55		0.53		2.76	36.3	241



Multiport Floating Ball

Components & Materials

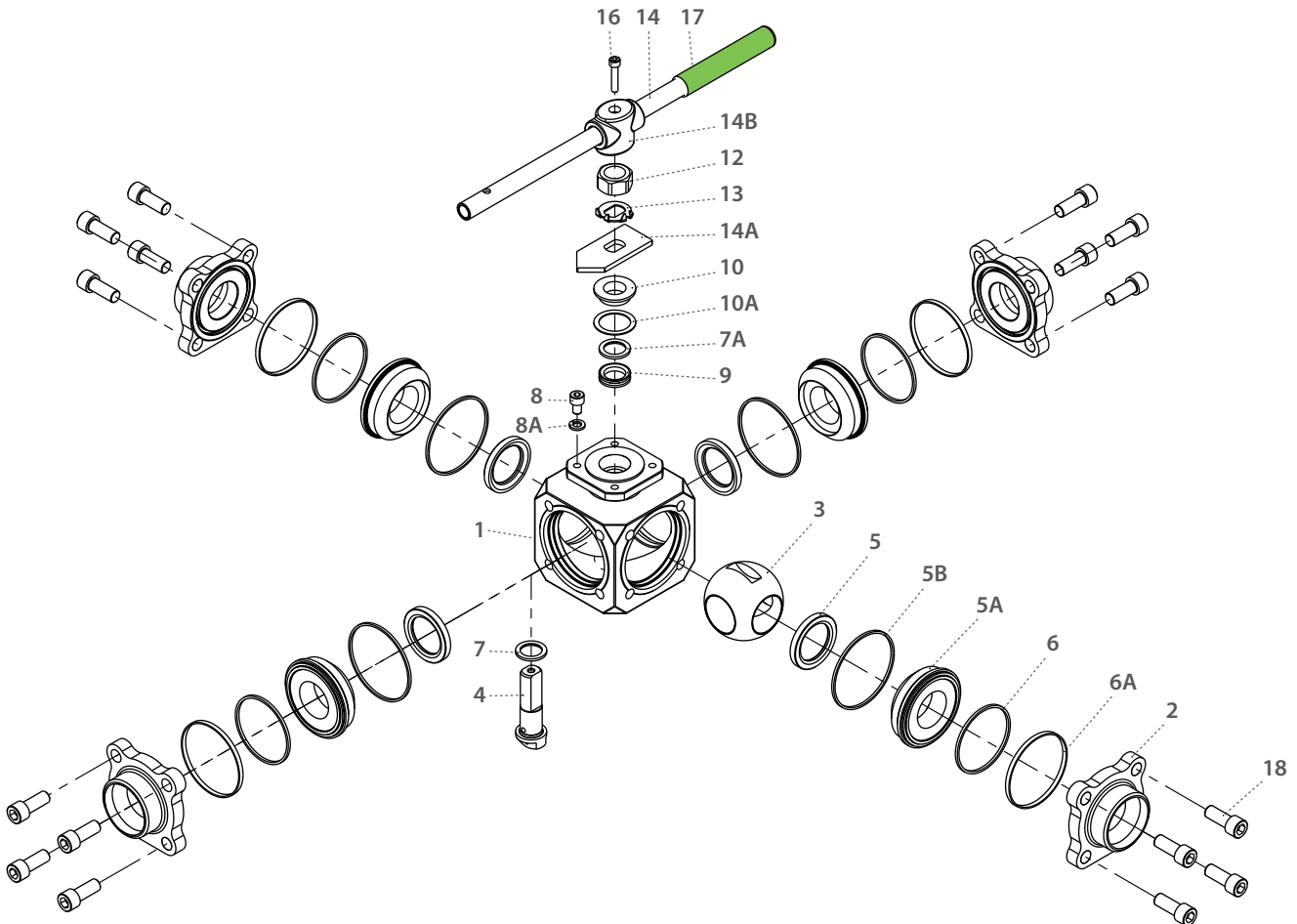

Item	Description	Material specification	Qty.
1	Body	Acc. Ordering Code	1
2	Ends	Acc. Ordering Code	5
3	Ball	Acc. Ordering Code	1
4	Stem	Acc. Ordering Code	1
5*	Seat	Acc. Ordering Code	4
5A	Support Seat	Acc. Ordering Code	4
5B*	Seat Seal	Acc. Ordering Code	4
6*	Inner Seal	Acc. Ordering Code	5
6A*	Outer Seal	Acc. Ordering Code	5
7*	Stem Thrust Seal	V. PEEK, CF PEEK, PCTFE	1
7A*	Anti-Abrasion Ring	V. PEEK, CF PEEK, PCTFE	1
8	Stop Pin	S. Steel	1

Item	Description	Material specification	Qty.
8A	Spring Washer	S. Steel	1
9*	Stem Seal	CF PTFE,TFM	1
10	Follower	S. Steel	1
10A*	Slide Braring	S. Steel	1
12	Stem Nut	S. Steel	1
13	Locking Clip	S. Steel	1
14	Handle	S. Steel	1
14A	Stop Plate	S. Steel	1
14B	Wrench Bolt	S. Steel	1
16	Handle Nut	S. Steel	1
17	Sleeve	PVC	1
18	Body Bolts	S. Steel	16

* Maintenance kit components

Multiport Floating Ball

Valve Dimensions

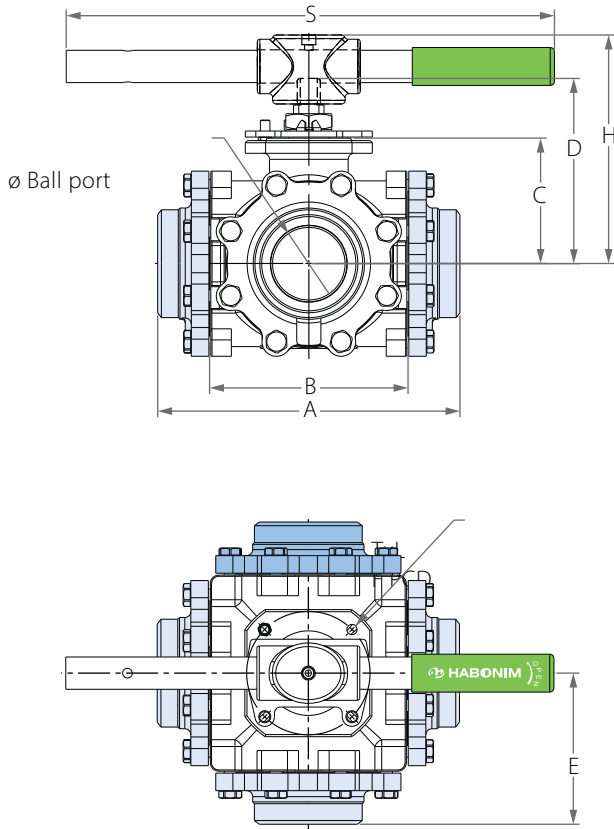

Preparation for actuation

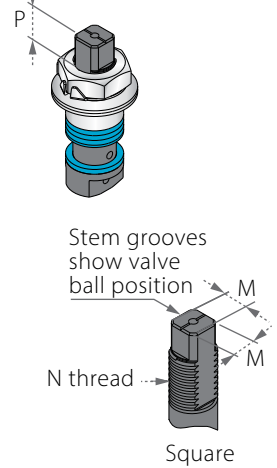

Valve Face To Face sizes are according to Habonim catalog data only, for Extended-weld/Flanged/Tri-clamp end see Face To Face sizes page.

Std. port	Unit	Ball port	A	B	C	D	E	H	M	M-DD	N	P	TxL	F	S	Weight kg/lb
DN80	mm	60.0	249.80	164.0	101.75	149.0	A/2	189.0	18.90	15.90	1"-14	16.70	M10x11	F10	610.0	40
3"	inch	2.36	9.83	6.46	4.01	5.86		7.44	0.74	0.63	UNS-2A	0.66				24.02
DN100	mm	76.0	309.80	205.0	134.50	168.0	A/2	264.0	28.45	23.75	1"-14	26.20	M12x14	F12	920.0	55
4"	inch	2.99	12.20	8.07	5.30	6.61		10.39	1.12	0.93	UNS-2A	1.03				36.22

Valve Size		Flow Coefficients	
mm	inch	KV	CV
DN80	3"	267	310
DN100	4"	484	562



Multiport Floating Ball

Components & Materials

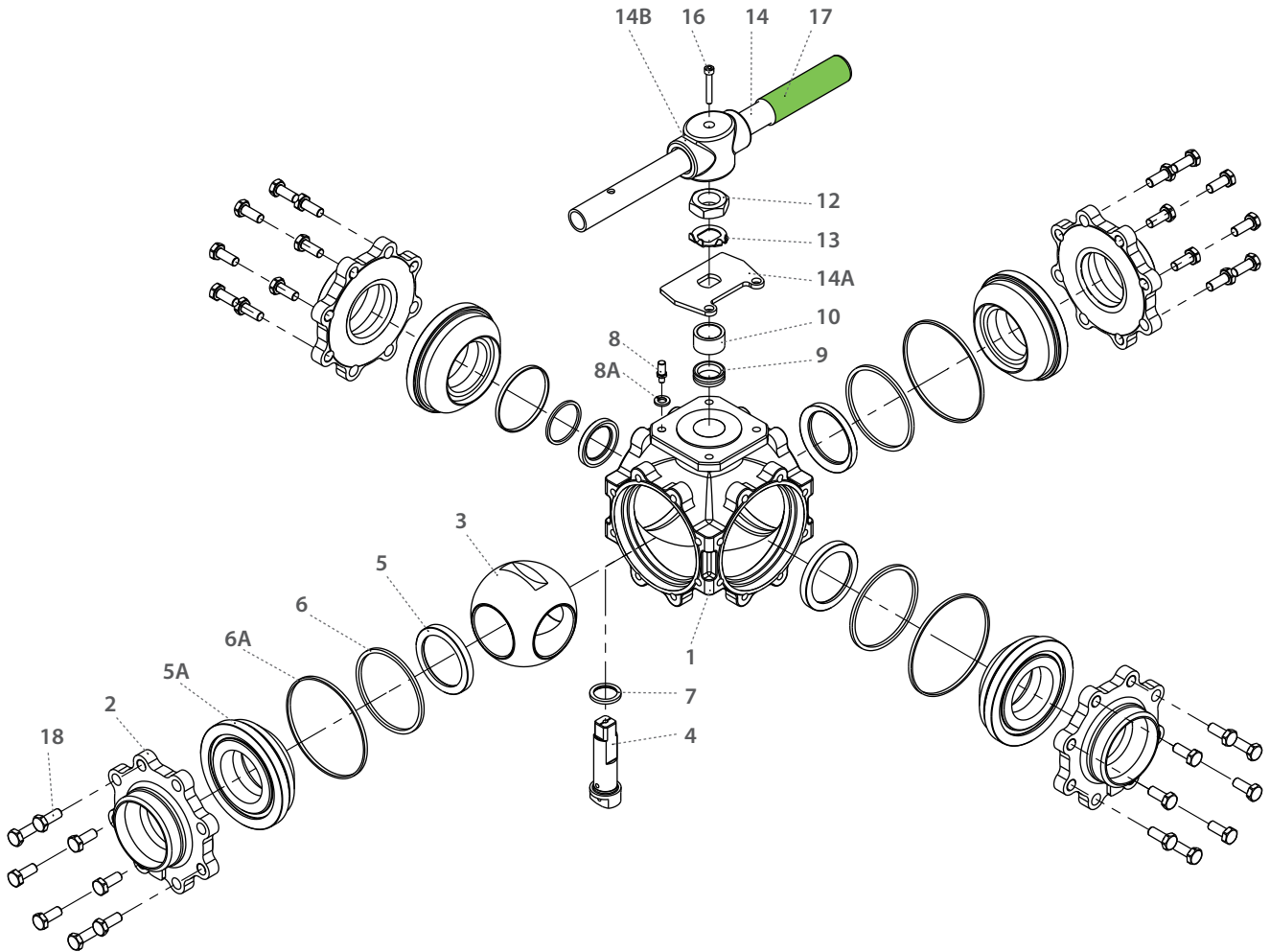

Item	Description	Material specification	Qty.
1	Body	Acc. Ordering Code	1
2	Ends	Acc. Ordering Code	4
3	Ball	Acc. Ordering Code	1
4	Stem	Acc. Ordering Code	1
5*	Seat	Acc. Ordering Code	4
5A	Support Seat	Acc. Ordering Code	4
6*	Seat Seal	Acc. Ordering Code	4
6A*	Body Seal	Acc. Ordering Code	5
7*	Stem Thrust Seal	PEEK, CF PEEK, PCTFE	1
8	Stop Bolt	S. Steel	1
8A	Spring Washer	S. Steel	1

Item	Description	Material specification	Qty.
9*	Stem Seal	CF PTFE,TFM	1
10	Follower	S. Steel	1
12	Stem Nut	S. Steel	1
13	Tab Lock Washer	S. Steel	1
14	Wrench Handle	C.St. Zinc Plate	1
14A	Stop Plate	S. Steel	1
14B	Wrench Head	S. Steel	1
16	Wrench Bolt	S. Steel	1
17	Sleeve	PVC	1
18	Body Bolt	S. Steel	32
23	Tag (not shown)	S. Steel	1

* Maintenance kit components

Multiport Floating Ball

Valve Dimensions

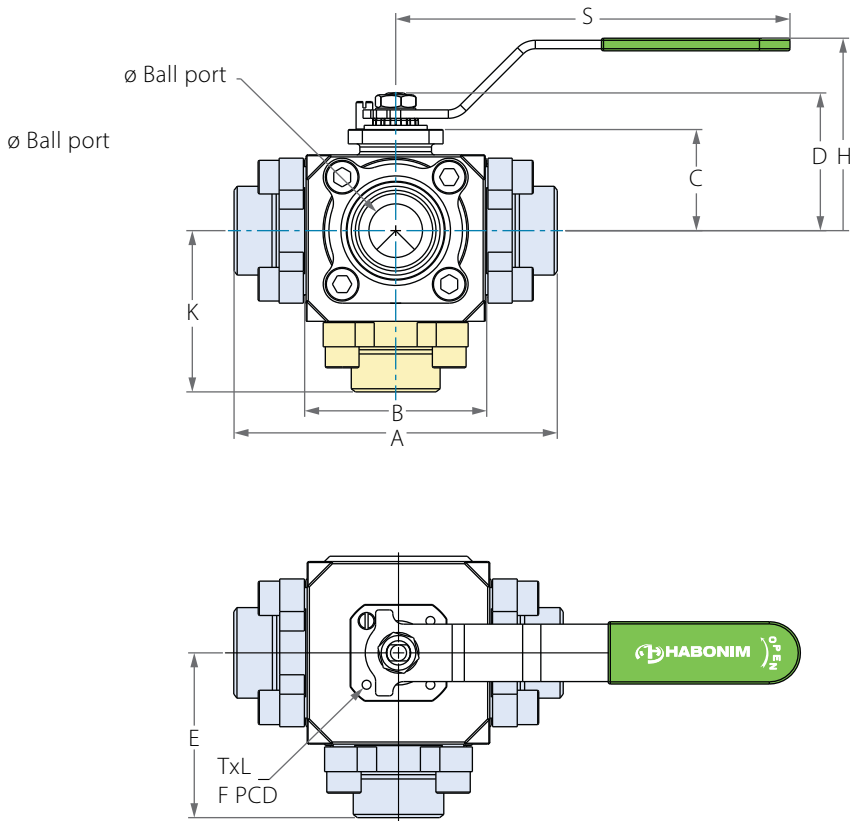

Preparation for actuation

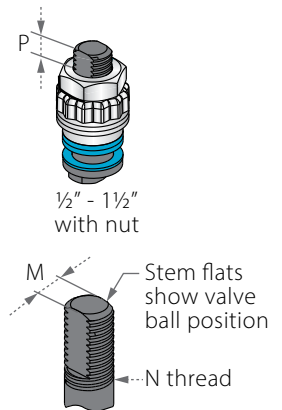

Valve Face To Face sizes are according to Habonim catalog data only, for Extended-weld/Flanged/Tri-clamp end see Face To Face sizes page.

Std. port	Full port	Unit	Ball port	A	B	C	D	E	H	K	S	M	N	P	TxL	F	PCD	Weight kg/lb
DN20	DN15	mm	14.3	113.0	67.0	38.1	55.6	A/2	80.0	52.7	187.0	7.54	7/16"	5.8	M5X8	F04	42.0	2.8
3/4"	1/2"	inch	0.56	4.45	2.64	1.50	2.19		3.15	2.07	7.36	0.30	UNF	0.23			1.65	6.16
DN25	DN20	mm	20.6	143.6	81.6	43.0	60.5		85.5	66.2	187	7.54	7/16"	5.8	M5X8	F04	42.0	4.3
1"	3/4"	inch	0.81	5.65	3.21	1.69	2.38		3.37	2.61	7.36	0.30	UNF	0.23			1.65	9.46
DN32	DN25	mm	25.4	153.4	86.4	48.0	65.5		90.0	76.5	187.0	7.54	7/16"	5.8	M5X8	F04	42.0	6
1 1/4"	1"	inch	1.0	6.04	3.40	1.89	2.58		3.54	3.01	7.36	0.30	UNF	0.23			1.65	13.2
DN40	DN32	mm	31.8	164.0	97.0	49.4	78.9		103	79.5	237.0	8.71	9/16"	7.8	M6X9	F05	50.0	7.5
1 1/2"	1 1/4"	inch	1.25	6.46	3.82	1.94	3.11		4.06	3.13	9.33	0.34	UNF	0.31			1.97	16.5

Valve Size		Flow Coefficients	
mm	inch	KV	CV
DN20	3/4"	9	11
DN25	1"	27	31
DN32	1 1/4"	47	55
DN40	1 1/2"	67	78



Multiport Floating Ball

Components & Materials

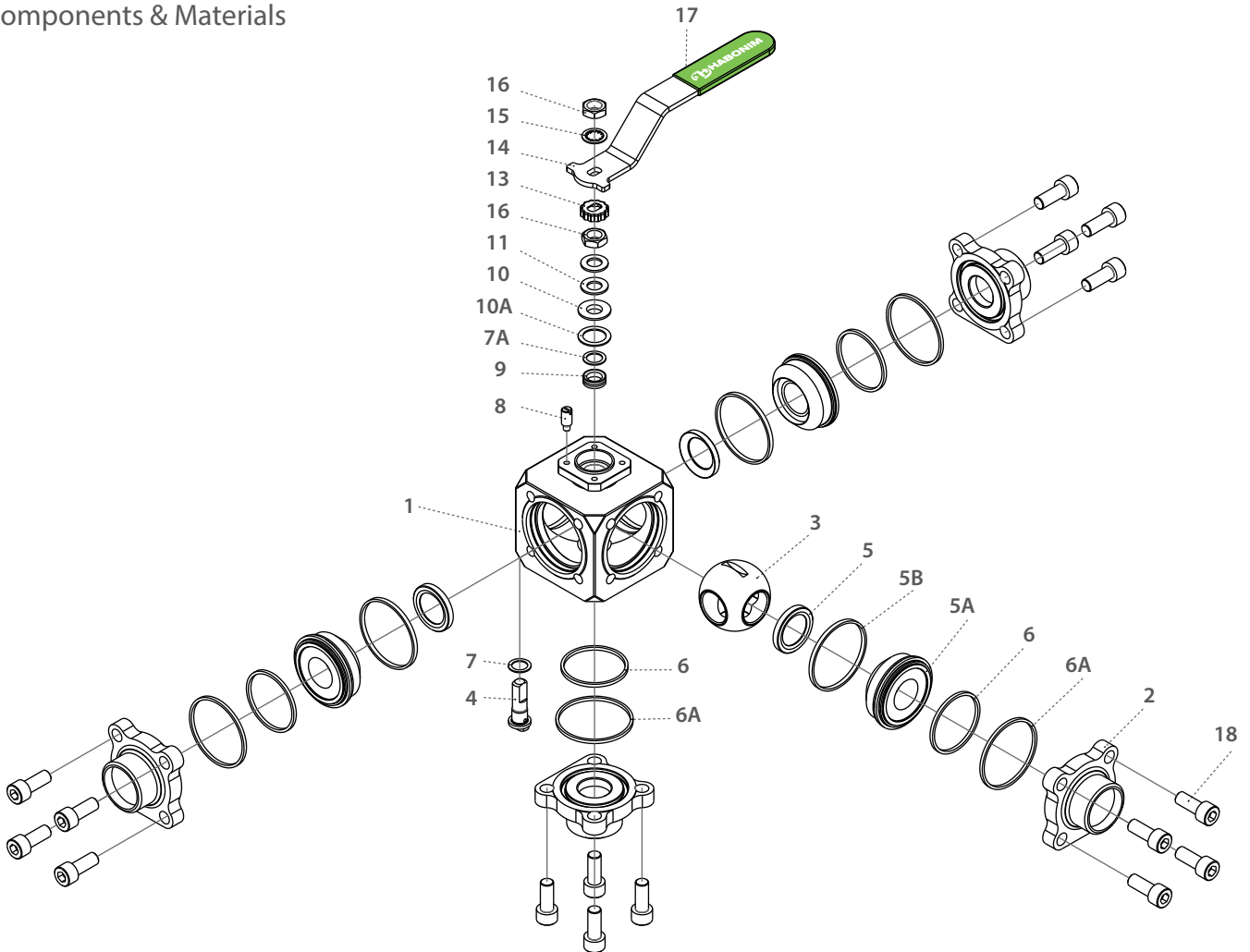

Item	Description	Material specification	Qty.
1	Body	Acc. Ordering Code	1
2	Ends	Acc. Ordering Code	5
3	Ball	Acc. Ordering Code	1
4	Stem	Acc. Ordering Code	1
5*	Seat	Acc. Ordering Code	4
5A	Support Seat	See body material	4
5B*	Seat Seal	Acc. Ordering Code	4
6*	Inner Seal	Acc. Ordering Code	5
6A*	Outer Seal	Acc. Ordering Code	5
7*	Stem Thrust Seal	PEEK, CF PEEK, PCTFE	1
7A*	Anti-Abrasion Ring	PEEK, CF PEEK, PCTFE	1
8	Stop Pin	S. Steel	1

Item	Description	Material specification	Qty.
9*	Stem Seal	CF PTFE,TFM	1
10	Follower	S. Steel	1
10A*	Slide Braring	S. Steel	1
11	Disc Spring	S. Steel	2
12	Stem Nut	S. Steel	1
13	Locking Clip	S. Steel	1
14	Handle	S. Steel	1
15	Serrated Washer	S. Steel	1
16	Handle Nut	S. Steel	1
17	Sleeve	PVC	1
18	Body Bolts	S. Steel	16

* Maintenance kit components

Multiport Floating Ball

Valve Dimensions

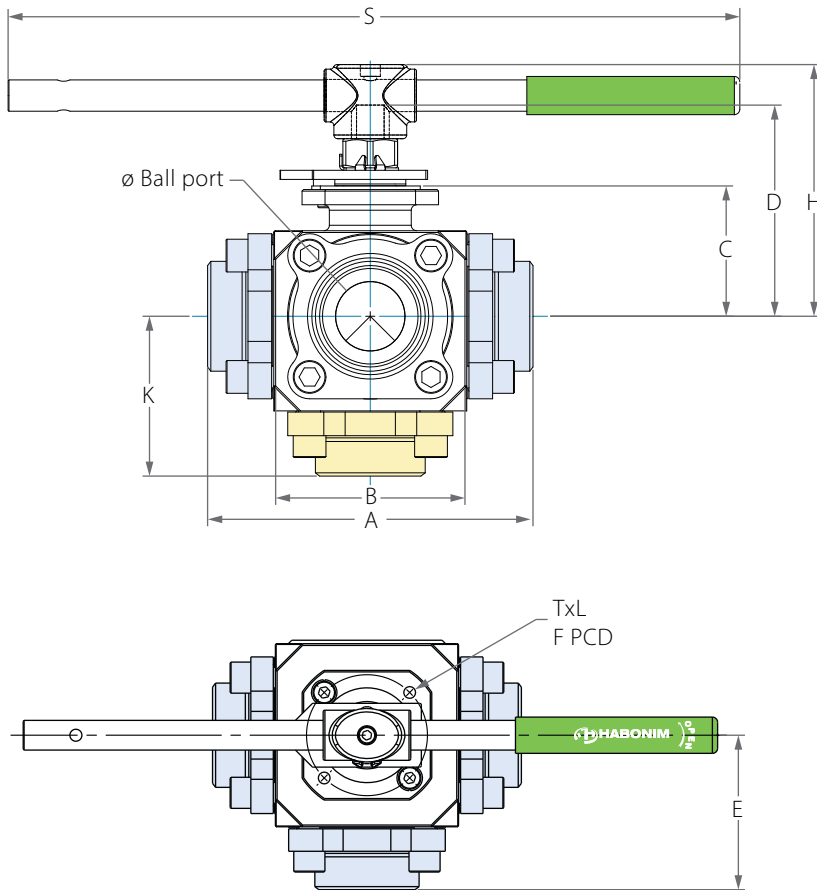

Preparation for actuation

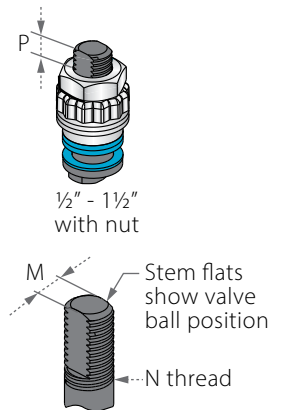

Valve Face To Face sizes are according to Habonim catalog data only, for Extended-weld/Flanged/Tri-clamp end see Face To Face sizes page.

Std. port	Full port	Ball port	A	B	C	D	E	H	K	S	M	N	P	TxL	PCD	Weight kg/lb	Kv Cv
DN50	DN40	38.1	177.2	107.2	69.7	111.3	A/2	140.0	35.0	400.0	13.9	M20x2.5	13.5	F07	70.0	11	102
2"	1½"	1.50	6.98	4.22	2.74	4.38		5.51	1.38	15.75	0.55		0.53		2.76	24.2	118
DN65	DN50	48.0	210.4	125.0	79.1	120.7		150.0	100.7	400.0	13.9	M20x2.5	13.5	F07	70.0	16.5	208
2½"	2"	1.89	8.28	4.92	3.11	4.75		5.91	3.96	15.75	0.55		0.53		2.76	36.3	241



Multiport Floating Ball

Components & Materials

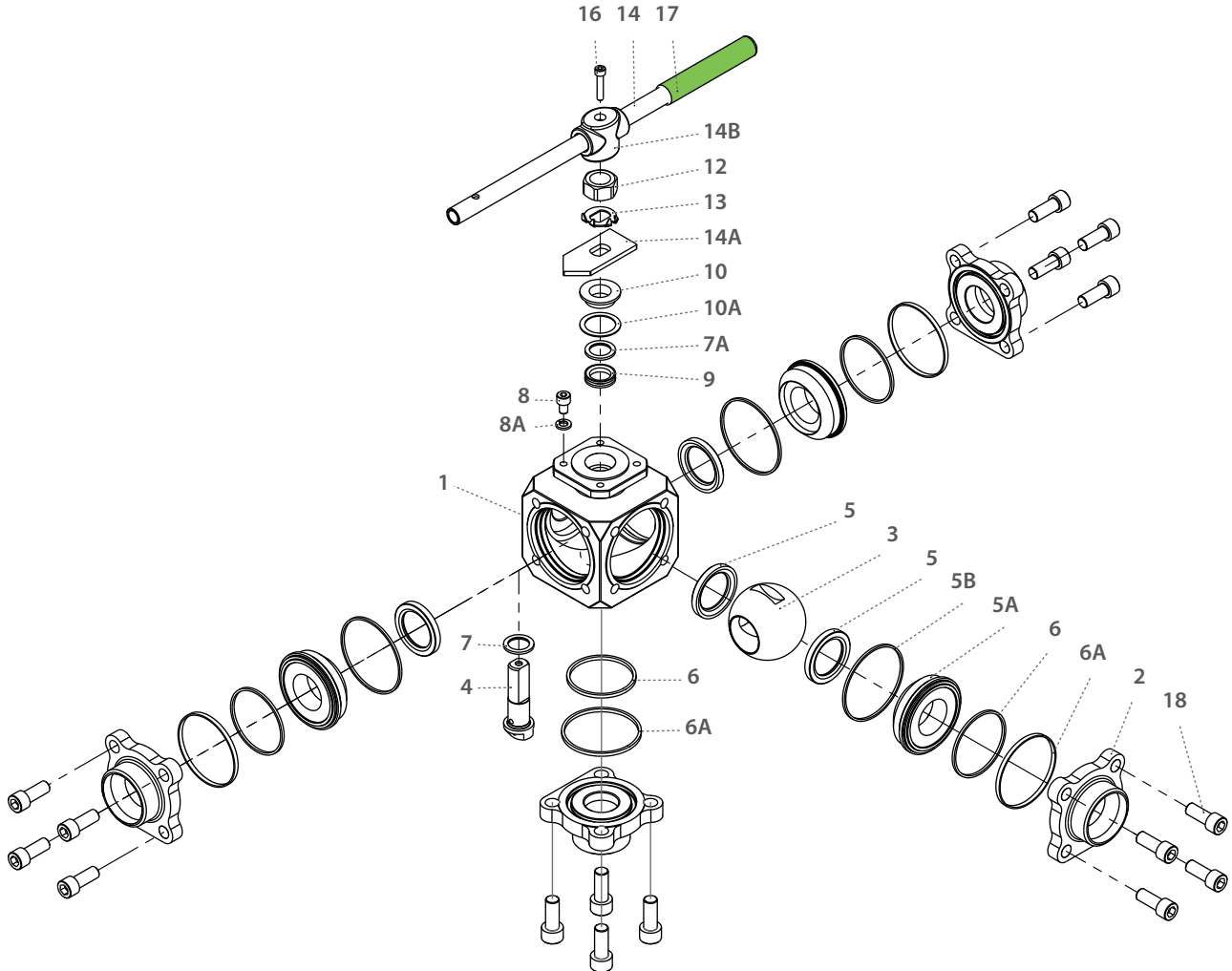

Item	Description	Material specification	Qty.
1	Body	Acc. Ordering Code	1
2	Ends	Acc. Ordering Code	5
3	Ball	Acc. Ordering Code	1
4	Stem	Acc. Ordering Code	1
5*	Seat	Acc. Ordering Code	4
5A	Support Seat	Acc. Ordering Code	4
5B*	Seat Seal	Acc. Ordering Code	4
6*	Inner Seal	Acc. Ordering Code	5
6A*	Outer Seal	Acc. Ordering Code	5
7*	Stem Thrust Seal	V. PEEK, CF PEEK, PCTFE	1
7A*	Anti-Abrasion Ring	V. PEEK, CF PEEK, PCTFE	1
8	Stop Pin	S. Steel	1

Item	Description	Material specification	Qty.
8A	Spring Washer	S. Steel	1
9*	Stem Seal	CF PTFE,TFM	1
10	Follower	S. Steel	1
10A*	Slide Braring	S. Steel	1
12	Stem Nut	S. Steel	1
13	Locking Clip	S. Steel	1
14	Handle	S. Steel	1
14A	Stop Plate	S. Steel	1
14B	Wrench Bolt	S. Steel	1
16	Handle Nut	S. Steel	1
17	Sleeve	PVC	1
18	Body Bolts	S. Steel	16

* Maintenance kit components

Multiport Floating Ball

Valve Dimensions

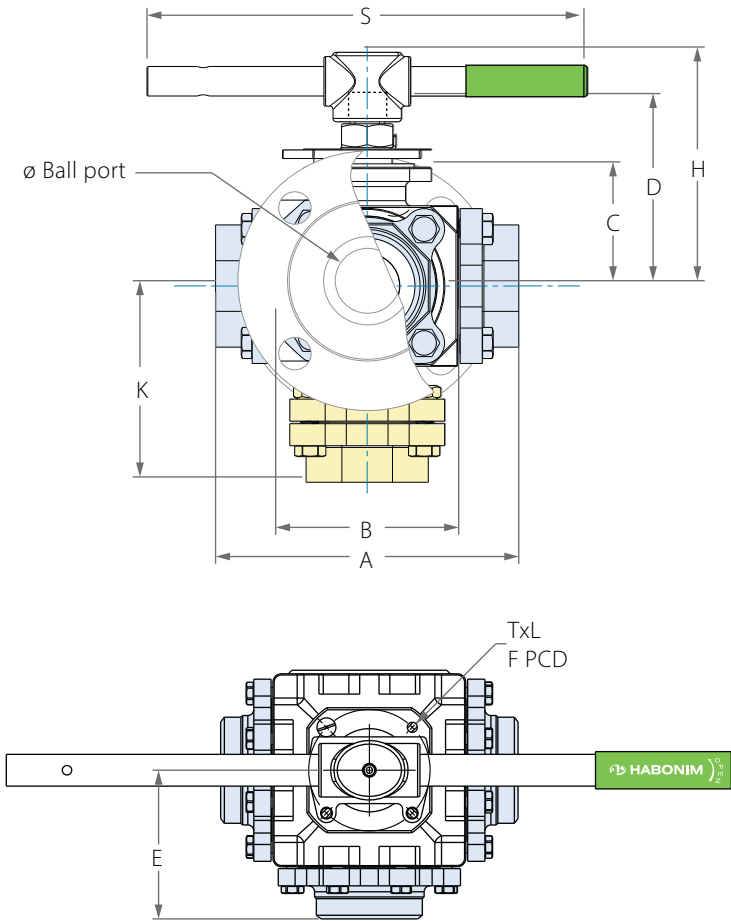

Preparation for actuation

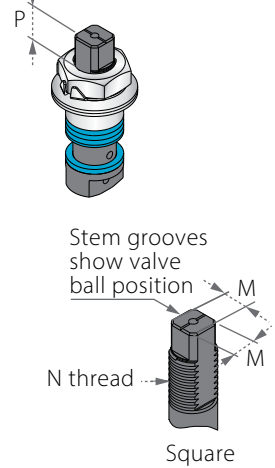

Valve Face To Face sizes are according to Habonim catalog data only, for Extended-weld/Flanged/Tri-clamp end see Face To Face sizes page.

Std. port	Unit	Ball port	A	B	C	D	E	K	H	M	M-DD	N	P	TxL	F	S	Weight kg/lb
DN80	mm	60.0	249.80	164.0	101.75	143.35	A/2	149.0	189.0	18.90	15.90	1"-14	16.70	M10x11	F10	610.0	40
3"	inch	2.36	9.83	6.46	4.01	5.64		5.87	7.44	0.74	0.63	UNS-2A	0.66			24.02	88
DN100	mm	76.0	309.80	205.0	134.50	203.60	A/2	190.0	264.0	28.45	23.75	1"-14	26.20	M12x14	F12	920.0	55
4"	inch	2.99	12.20	8.07	5.30	8.02		7.48	10.39	1.12	0.93	UNS-2A	1.03			36.22	121

Valve Size		Flow Coefficients	
mm	inch	KV	CV
DN80	3"	267	310
DN100	4"	484	562



Multiport Floating Ball

Components & Materials

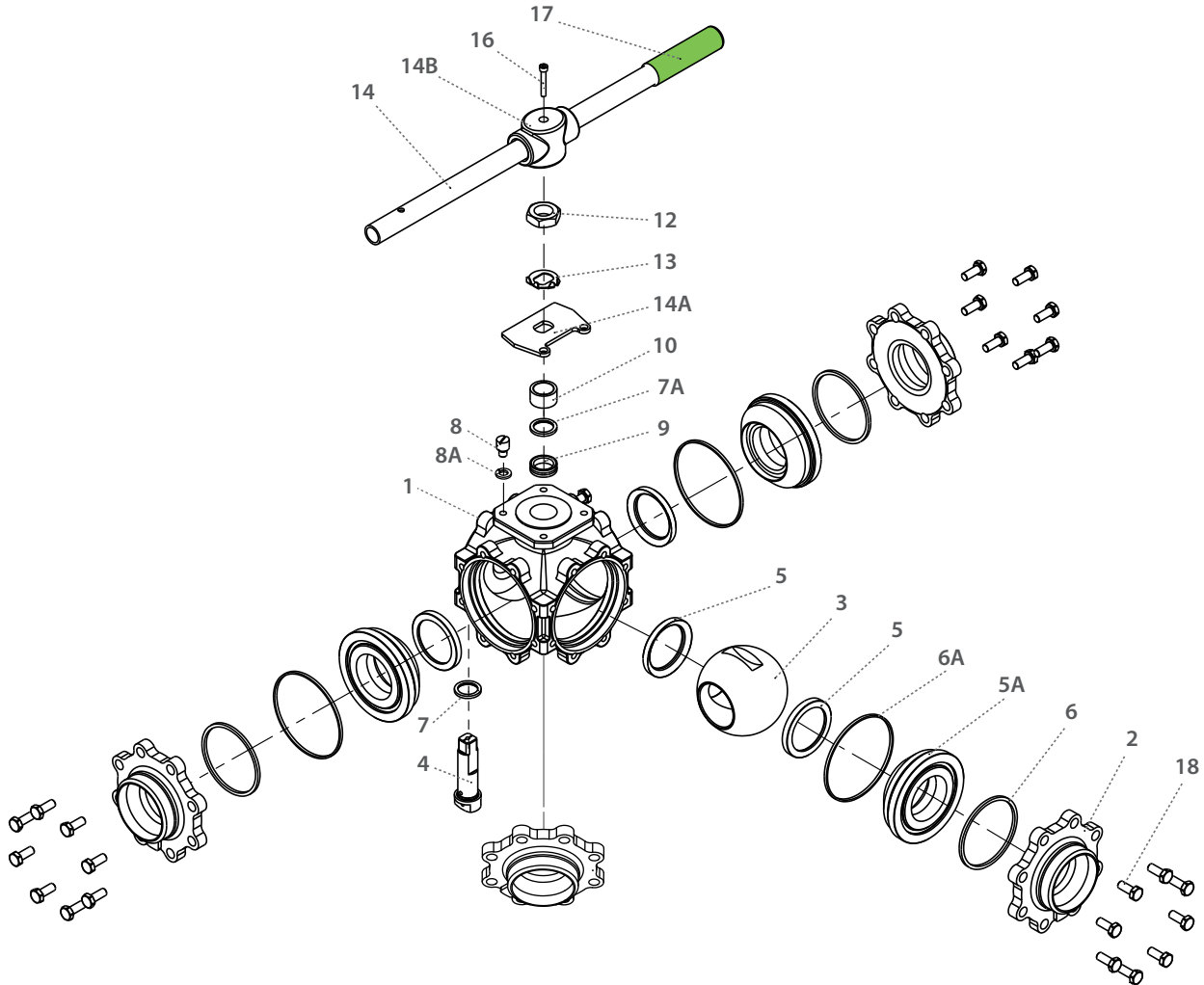

Item	Description	Material specification	Qty.
1	Body	Acc. Ordering Code	1
2	Ends	Acc. Ordering Code	4
3	Ball	Acc. Ordering Code	1
4	Stem	Acc. Ordering Code	1
5*	Seat	Acc. Ordering Code	4
5A	Support Seat	Acc. Ordering Code	4
6*	Seat Seal	Acc. Ordering Code	4
6A*	Body Seal	Acc. Ordering Code	5
7*	Stem Thrust Seal	PEEK, CF PEEK, PCTFE	1
8	Stop Bolts	S. Steel	1
8A	Spring Washer	S. Steel	1

Item	Description	Material specification	Qty.
9*	Stem Seal	CF PTFE,TFM	1
10	Follower	S. Steel	1
12	Stem Nut	S. Steel	1
13	Tab Lock Washer	S. Steel	1
14	Wrench Handle	C.St. Zinc Plate	1
14A	Stop Plate	S. Steel	1
14B	Wrench Head	S. Steel	1
16	Wrench Bolt	S. Steel	1
17	Sleeve	PVC	1
18	Body Bolt	S. Steel	24
23	Tag (not shown)	S. Steel	1

* Maintenance kit components

Multiport Floating Ball

Valve Dimensions

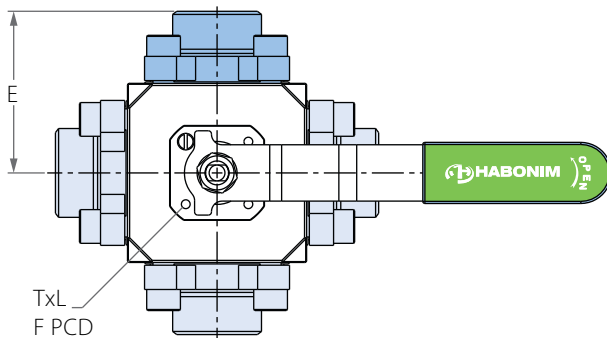
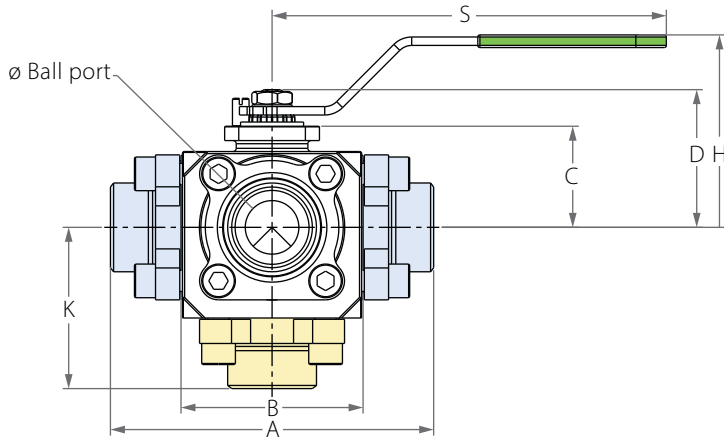

Preparation for actuation

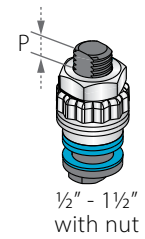

1/2" - 1 1/2"
with nut

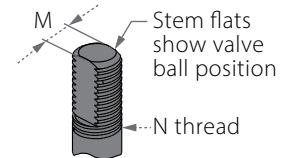

Stem flats show valve ball position

N thread

Valve Face To Face sizes are according to Habonim catalog data only, for Extended-weld/Flanged/Tri-clamp end see Face To Face sizes page.

Std. port	Full port	Unit	Ball port	A	B	C	D	E	H	K	S	M	N	P	TxL	F	PCD	Weight kg/lb
DN20	DN15	mm	14.3	113.0	67.0	38.1	55.6	A/2	80.0	52.7	187.0	7.54	7/16"	5.8	M5X8	F04	42.0	2.8
3/4"	1/2"	inch	0.56	4.45	2.64	1.50	2.19		3.15	2.07	7.36	0.30	UNF	0.23			1.65	6.16
DN25	DN20	mm	20.6	143.6	81.6	43.0	60.5		85.5	66.2	187.0	7.54	7/16"	5.8	M5X8	F04	42.0	4.3
1"	3/4"	inch	0.81	5.65	3.21	1.69	2.38		3.37	2.61	7.36	0.30	UNF	0.23			1.65	9.46
DN32	DN25	mm	25.4	153.4	86.4	48.0	65.5		90.0	76.5	187.0	7.54	7/16"	5.8	M5X8	F04	42.0	6
1 1/4"	1"	inch	1.0	6.04	3.40	1.89	2.58		3.54	3.01	7.36	0.30	UNF	0.23			1.65	13.2
DN40	DN32	mm	31.8	164.0	97.0	49.4	78.9	103.0	79.5	237.0	8.71	9/16"	7.8	M6X9	F05	50.0	7.5	
1 1/2"	1 1/4"	inch	1.25	6.46	3.82	1.94	3.11	4.06	3.13	9.33	0.34	UNF	0.31			1.97	16.5	

Valve Size		Flow Coefficients	
mm	inch	KV	CV
DN20	3/4"	9	11
DN25	1"	27	31
DN32	1 1/4"	47	55
DN40	1 1/2"	67	78



Multiport Floating Ball

Components & Materials

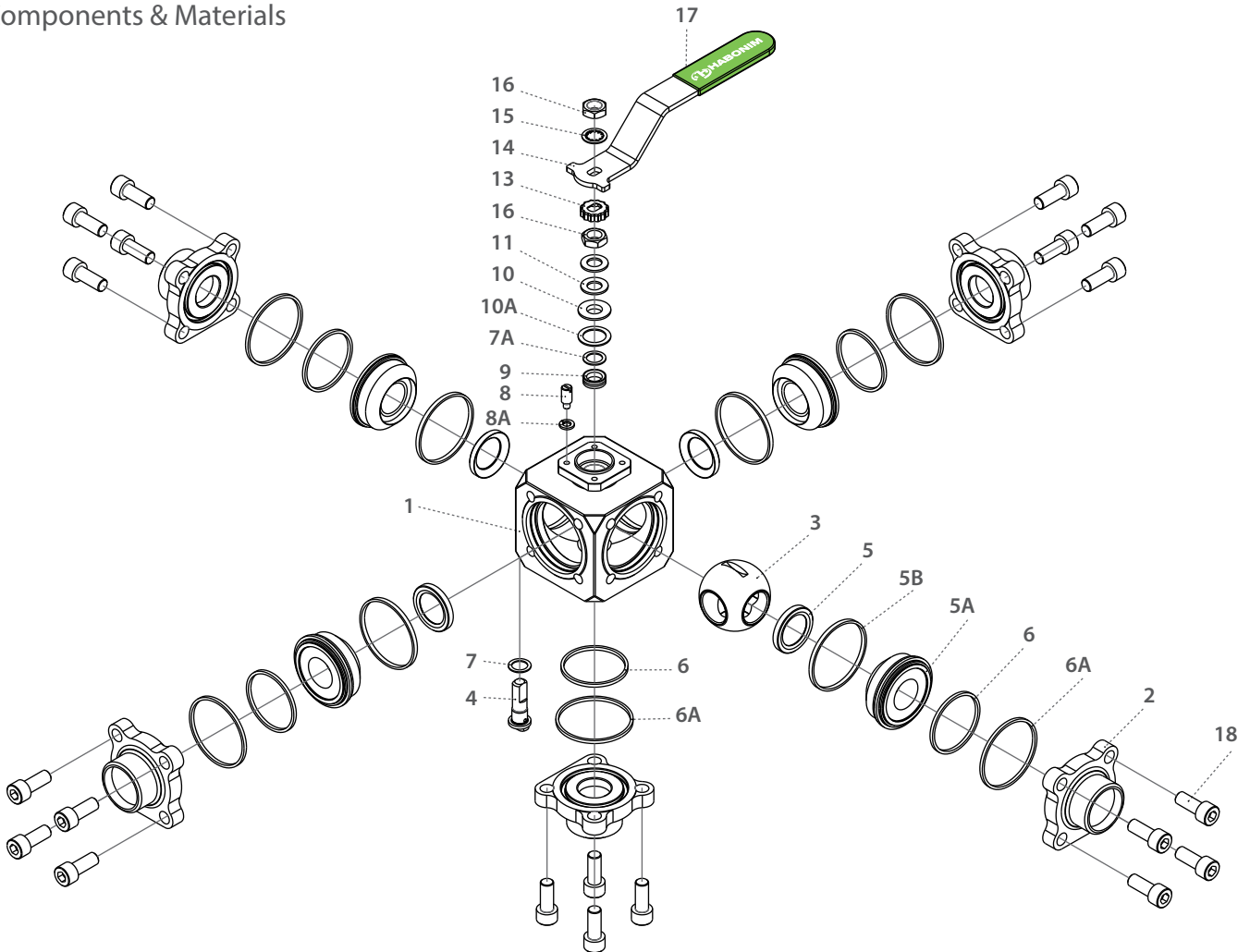

Item	Description	Material specification	Qty.
1	Body	Acc. Ordering Code	1
2	Ends	Acc. Ordering Code	5
3	Ball	Acc. Ordering Code	1
4	Stem	Acc. Ordering Code	1
5*	Seat	Acc. Ordering Code	4
5A	Support Seat	See body material	4
5B*	Seat Seal	Acc. Ordering Code	4
6*	Inner Seal	Acc. Ordering Code	5
6A*	Outer Seal	Acc. Ordering Code	5
7*	Stem Thrust Seal	PEEK, CF PEEK, PCTFE	1
7A*	Anti-Abrasion Ring	PEEK, CF PEEK, PCTFE	1
8	Stop Pin	S. Steel	1
8A	Spring Washer	S. Steel	1

Item	Description	Material specification	Qty.
9*	Stem Seal	CF PTFE,TFM	1
10	Follower	S. Steel	1
10A*	Slide Braring	S. Steel	1
11	Disc Spring	S. Steel	2
12	Stem Nut	S. Steel	1
13	Locking Clip	S. Steel	1
14	Handle	S. Steel	1
15	Serrated Washer	S. Steel	1
16	Handle Nut	S. Steel	1
17	Sleeve	PVC	1
18	Body Bolts	S. Steel	20

* Maintenance kit components

Multiport Floating Ball

Valve Dimensions

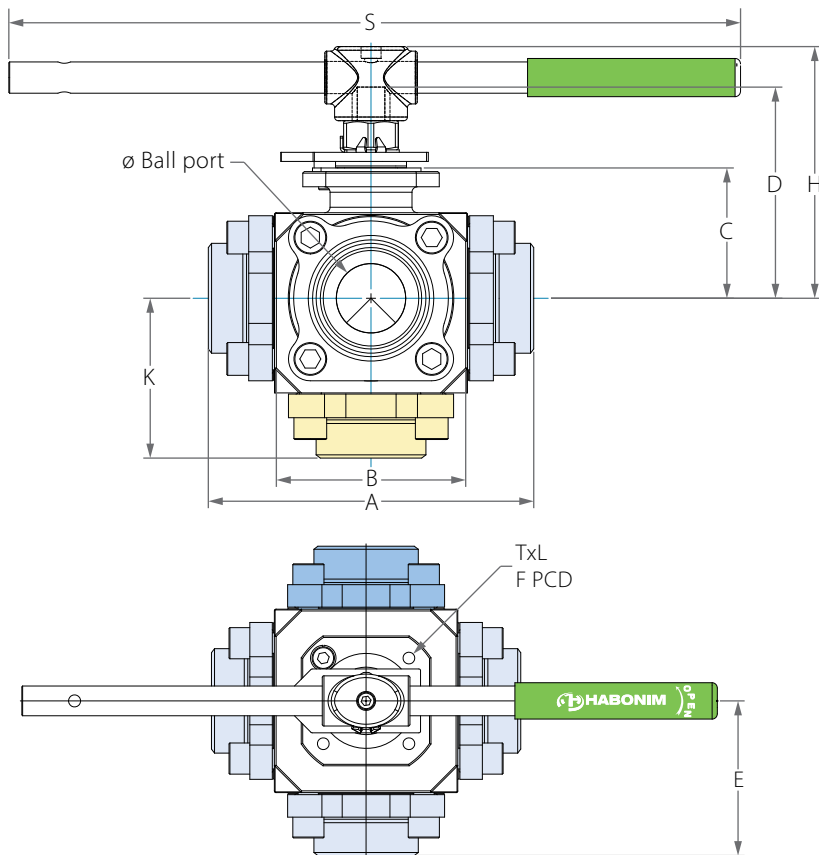

Preparation for actuation

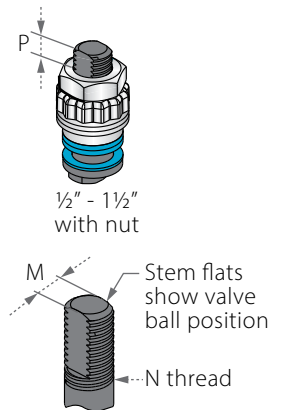

Valve Face To Face sizes are according to Habonim catalog data only, for Extended-weld/Flanged/Tri-clamp end see Face To Face sizes page.

Std. port	Full port	Ball port	A	B	C	D	E	H	K	S	M	N	P	TxL	PCD	Weight kg/lb	Kv Cv
DN50	DN40	38.1	177.2	107.2	69.7	111.3	A/2	140.0	35.0	400.0	13.9	M20x2.5	13.5	F07	70.0	11	102
2"	1½"	1.50	6.98	4.22	2.74	4.38		5.51	1.38	15.75	0.55		0.53		2.76	24.2	118
DN65	DN50	48.0	210.4	125.0	79.1	120.7		150.0	100.7	400.0	13.9	M20x2.5	13.5	F07	70.0	16.5	208
2½"	2"	1.89	8.28	4.92	3.11	4.75		5.91	3.96	15.75	0.55		0.53		2.76	36.3	241



Multiport Floating Ball

Components & Materials

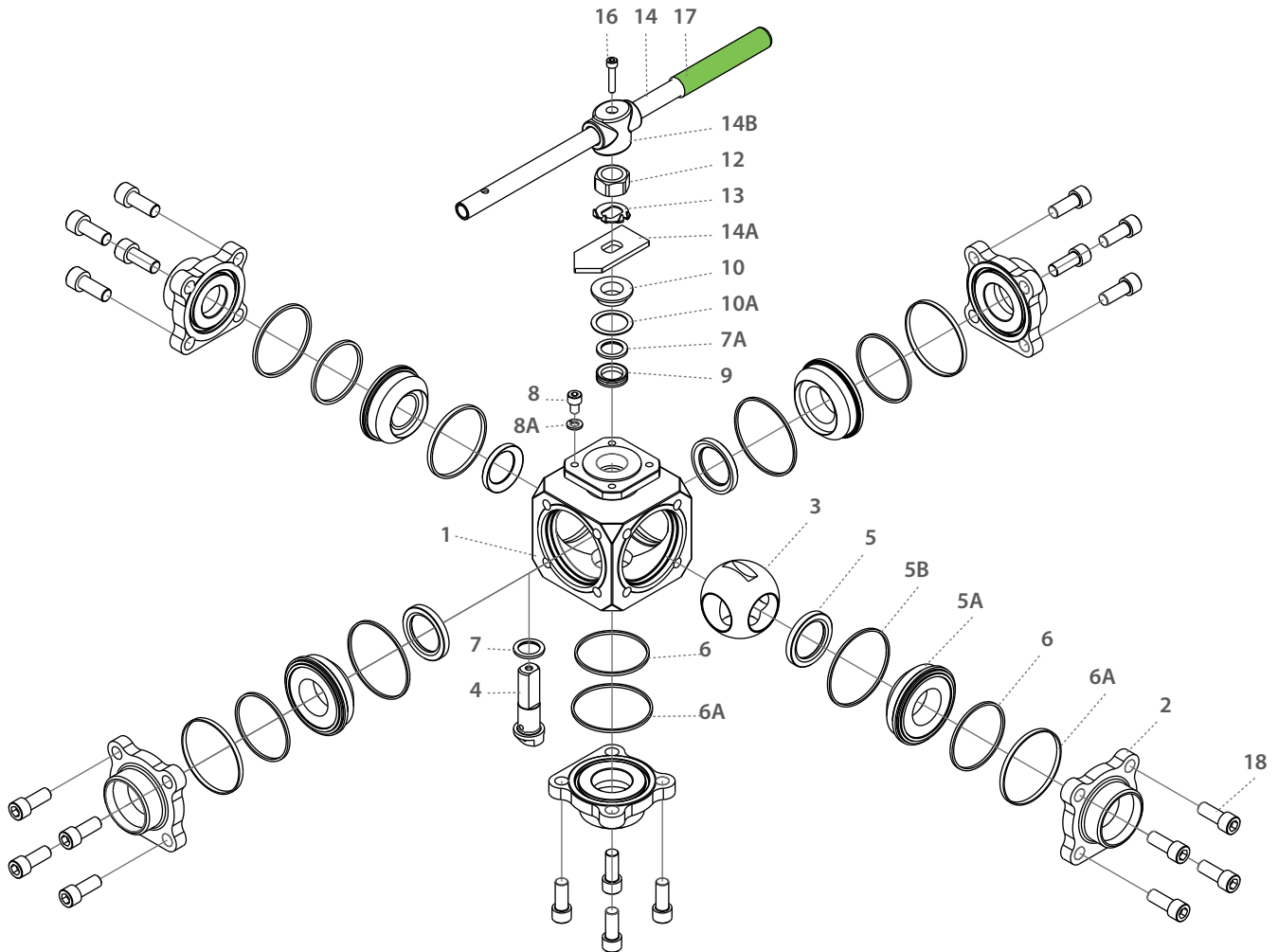

Item	Description	Material specification	Qty.
1	Body	Acc. Ordering Code	1
2	Ends	Acc. Ordering Code	5
3	Ball	Acc. Ordering Code	1
4	Stem	Acc. Ordering Code	1
5*	Seat	Acc. Ordering Code	4
5A	Support Seat	Acc. Ordering Code	4
5B*	Seat Seal	Acc. Ordering Code	4
6*	Inner Seal	Acc. Ordering Code	5
6A*	Outer Seal	Acc. Ordering Code	5
7*	Stem Thrust Seal	V. PEEK, CF PEEK, PCTFE	1
7A*	Anti-Abrasion Ring	V. PEEK, CF PEEK, PCTFE	1
8	Stop Pin	S. Steel	1

Item	Description	Material specification	Qty.
8A	Spring Washer	S. Steel	1
9*	Stem Seal	CF PTFE,TFM	1
10	Follower	S. Steel	1
10A*	Slide Braring	S. Steel	1
12	Stem Nut	S. Steel	1
13	Locking Clip	S. Steel	1
14	Handle	S. Steel	1
14A	Stop Plate	S. Steel	1
14B	Wrench Bolt	S. Steel	1
16	Handle Nut	S. Steel	1
17	Sleeve	PVC	1
18	Body Bolts	S. Steel	20

* Maintenance kit components

Multiport Floating Ball

Valve Dimensions

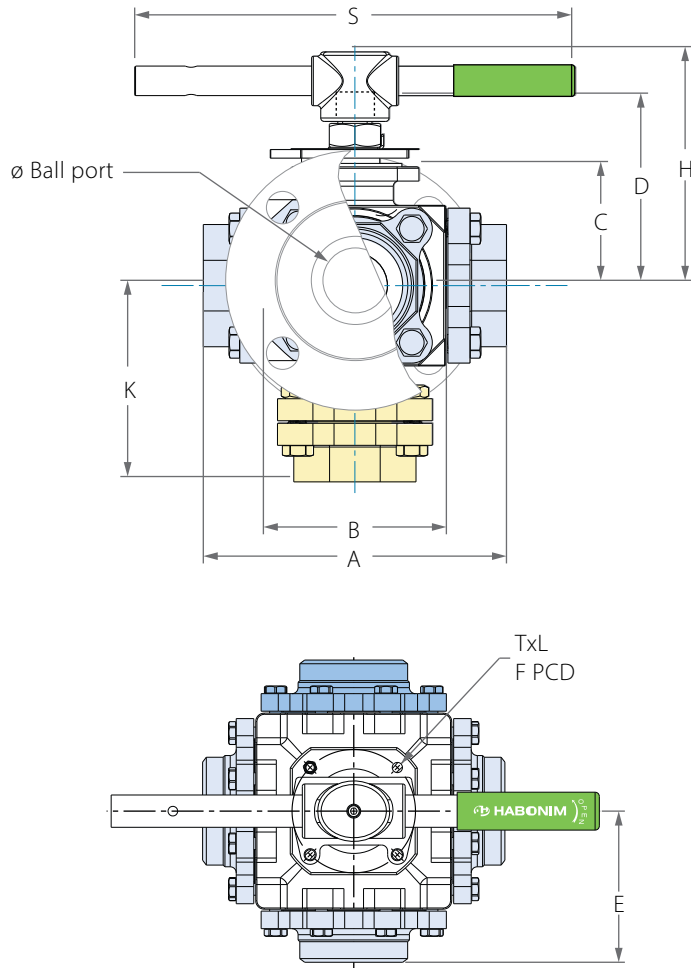

Preparation for actuation

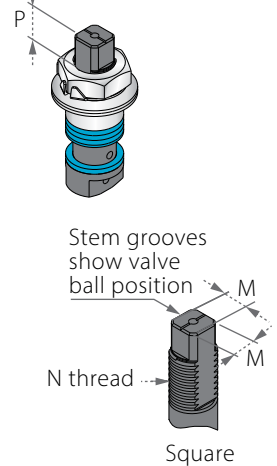

Valve Face To Face sizes are according to Habonim catalog data only, for Extended-weld/Flanged/Tri-clamp end see Face To Face sizes page.

Std. port	Unit	Ball port	A	B	C	D	E	K	H	M	M-DD	N	P	TxL	F	S	Weight kg/lb
DN80	mm	60.0	249.80	164.0	101.75	143.35	A/2	149.0	189.0	18.90	15.90	1"-14	16.70	M10x11	F10	610.0	40
3"	inch	2.36	9.83	6.46	4.01	5.64		5.87	7.44	0.74	0.63	UNS-2A	0.66			24.02	46
DN100	mm	76.0	309.80	205.0	134.50	203.60	A/2	190.0	264.0	28.45	23.75	1"-14	26.20	M12x14	F12	920.0	55
4"	inch	2.99	12.20	8.07	5.30	8.02		7.48	10.39	1.12	0.93	UNS-2A	1.03			36.22	64

Valve Size		Flow Coefficients	
mm	inch	KV	CV
DN80	3"	267	310
DN100	4"	484	562



Multiport Floating Ball

Components & Materials

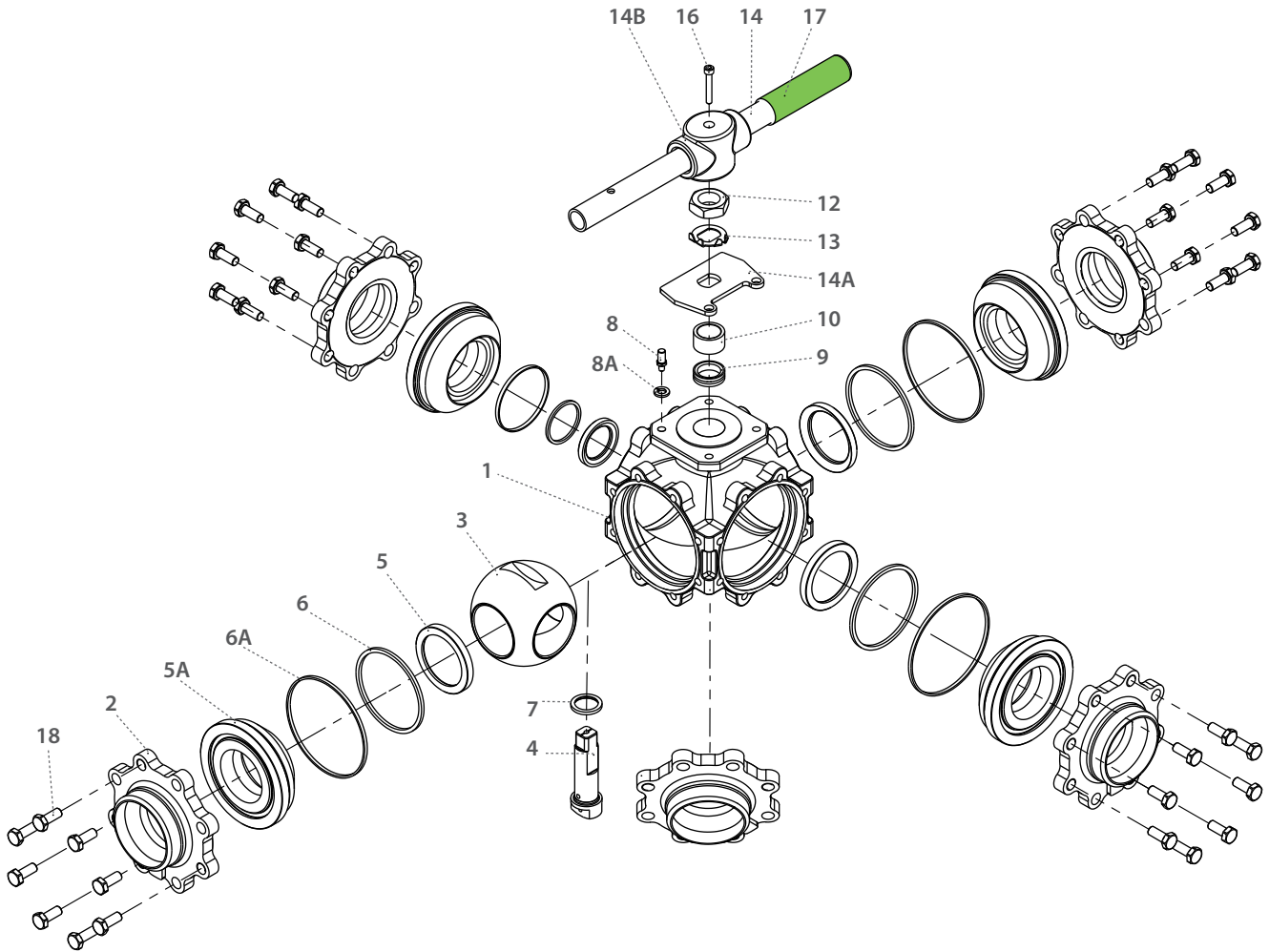

Item	Description	Material specification	Qty.
1	Body	Acc. Ordering Code	1
2	Ends	Acc. Ordering Code	4
3	Ball	Acc. Ordering Code	1
4	Stem	Acc. Ordering Code	1
5*	Seat	Acc. Ordering Code	4
5A	Support Seat	Acc. Ordering Code	4
6*	Seat Seal	Acc. Ordering Code	4
6A*	Body Seal	Acc. Ordering Code	5
7*	Stem Thrust Seal	PEEK, CF PEEK, PCTFE	1
8	Stop Bolts	S. Steel	1
8A	Spring Washer	S. Steel	1

Item	Description	Material specification	Qty.
9*	Stem Seal	CF PTFE,TFM	1
10	Follower	S. Steel	1
12	Stem Nut	S. Steel	1
13	Tab Lock Washer	S. Steel	1
14	Wrench Handle	C.St. Zinc Plate	1
14A	Stop Plate	S. Steel	1
14B	Wrench Head	S. Steel	1
16	Wrench Bolt	S. Steel	1
17	Sleeve	PVC	1
18	Body Bolt	S. Steel	32
23	Tag (not shown)	S. Steel	1

* Maintenance kit components

61

62

D61

D62

Face To Face Sizes

Valve Size	Unit	B		A-XBW / ETI / ETD / GR		A-ETO	A-Flanged CLASS 150+300		A-Flanged CLASS 600		A-Flanged DIN		A-TC
		Std. port	Full port	Std. port	Full port	Std. port	Std. port	Full port	Std. port	Full port	Std. port	Full port	Full port
DN15	mm		67.0		189.4			182.4		194.4		172.4	
1/2"	inch		2.64		7.46			7.18		7.65		6.79	
DN20	mm	67.0	81.6	189.4	218.6	189.4	194.4	202.2	194.4	215.0	192.4	200.0	144.0
3/4"	inch	2.64	3.21	7.46	8.61	7.46	7.65	7.96	7.65	8.46	7.57	7.87	5.67
DN25	mm	81.6	86.4	218.6	224.4	213.9	214.8	210.2	265.8	223.1	209.8	205.2	164.2
1"	inch	3.21	3.40	8.61	8.83	8.42	8.46	8.28	10.46	8.78	8.26	8.08	6.46
DN32	mm	86.4	97.0	224.4	238.0	224.4	223.1	226.6	223.1	226.6	225.2	228.6	86.4
1 1/4"	inch	3.40	3.82	8.83	9.37	8.83	8.78	8.92	8.78	8.92	8.87	9.0	3.40
DN40	mm	97.0	107.2	238.0	251.2	232.6	238.6	241.4	290.0	267.0	248.6	251.0	188.4
1 1/2"	inch	3.82	4.22	9.37	9.89	9.16	9.39	9.50	11.42	10.51	9.79	9.88	7.42
DN50	mm	107.2	125.0	251.2	285.0	244.4	266.9	268.2			280.8	282.4	209.8
2"	inch	4.22	4.92	9.89	11.22	9.62	10.51	10.56			11.06	11.12	8.26
DN65	mm	125.0	164.0	285.0	364.0	285.0	293.4	362.6			284.7	350.6	265.4
2 1/2"	inch	4.92	6.46	11.22	14.33	11.22	11.55	14.28			11.21	13.80	10.45
DN80	mm	164.0	205.0	364.0	445.0	364.0	362.7	378.4			360.6	406.2	164.0
3"	inch	6.46	8.07	14.33	17.52	14.33	14.28	14.90			14.20	15.99	6.46
DN100	mm	205.0		445.0		445.0	401.0				446.2		205.0
4"	inch	8.07		17.52		17.52	15.79				17.57		8.07

XBW / ETO / ETI / ETD / GR

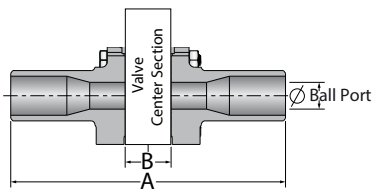

Flanged

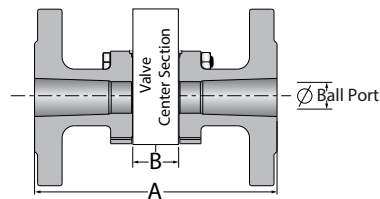

TC

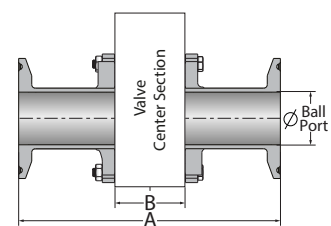
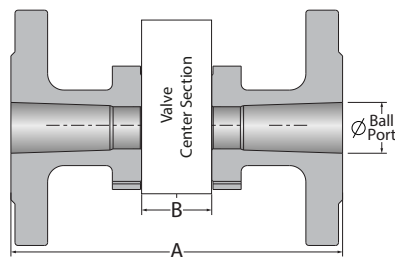
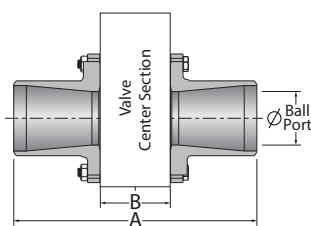
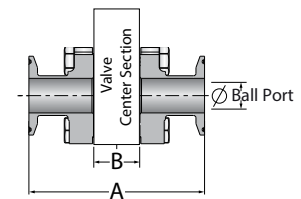



Multiport Floating Ball - Ordering Code System

"Mandatory option" options are marked with **green background** | "Standard offer" options are marked with **light green background**

1	2	3	4	5	6	7	8	9	10	11	12	13	14	15	16	17	18	19	20	21	22	23	24	25	26	27	28	29	30
2	0				D	6	1	W	-	6	6	6	6	A	T	A	/	B	W			-	#	0	3	4			
Size		Features				Series		Design		Body/end material		Ball/Stem material		Seat material	Body/seat seal	Outer Seal Material	End connection				Flow pattern code			Special features					

Size (1-2)		
Code	inch	mm
05	½"	15
07	¾"	20
10	1"	25
12	1¼"	32
15	1½"	40
20	2"	50
25	2½"	65
30	3"	80
40	4"	100

Features (3-6)	
B *	Full port
D	Diverter bottom entry
F	Shell only -fire safe
O	Clean assembly for O2 service
H**	Hydrogen service

* up to 3"
** for material selection - see Hydrogen Service chapter

Series (7-8)	
61	Multiport with three horizontal ports
62	Multiport with four horizontal ports
Design (9)	
W*	Total HermetiX Integrity Package
X**	HermetiX stem seal

* Up to 2½"/2" full bore
** 3" to 4"

Body/Ends material (11-12)	
6	S. SteelCF8M/CF3M*

* CF3M - for welded ends only

Ball material (13)	
Stem material (14)	
6	S. SteelCF8M/316
6	S. Steel316
M	High Strength S. Steel

Seat material (15)	
A	TFM
P	CF PTFE

Body seal (16)	
T	PTFE
G	Expanded graphite
A	TFM

Outer seal material* (17)	
A	TFM
G	Expanded graphite

* Up to 2½"/2" full bore

End Connection (19-22)	
Welded ends	
BW10	Buttweld schd. 10
BW	Buttweld schd. 40
XBW10	Extended buttweld schd. 10
XBW	Extended buttweld schd. 40
BW5	Buttweld schd. 5
BWD	Buttweld DIN 11850
SW	Socket weld
SWO*	Socket weld tube OD
BWO*	Buttweld tube OD
ETO*	Extended tube OD
XSW	Extended socket weld
Threaded	
NPT	ASME B1.20.1 - National Pipe Taper thread
BSPT	EN 10226 - Pipe Taper thread
MNPT	Male NPT
MBSPT	Male BSPT
BSPP	ISO228-1, DIN3852 - Pipe Parallel thread
DIN3852	DIN3852 - Pipe Parallel thread
AS5202	SAE internal straight thread
Flanged	
150	ASME B16.5 #150 RF
300	ASME B16.5 #300 RF
600	ASME B16.5 #600 RF
PN16	EN1092 PN16 RF
PN40	EN1092 PN40 RF
PN63	EN1092 PN63 RF
PN100	EN1092 PN100 RF
Clamp	
LL*	Compression fitting (Imperial) - No Nuts & Ferrules
LM*	Compression fitting (metric) - No Nuts & Ferrules
LL-NF*	Compression fitting (Imperial) - with Nuts & Ferrules
LM-NF*	Compression fitting (metric) - with Nuts & Ferrules
TC*	Tri-Clamp
GR**	Grayloc® compatible hub (Grayloc® is a registered trademark of Grayloc Products, L.L.C.)

* Std. port only

** Not available for 1¼" (DN32) Valves

Flow pattern code (24-27)	
#001	3 way side entry
#028	
#029	3 way bottom entry
#031	
#032	
#063	4 way bottom entry
#064	
#073	4 way side entry
#074	
#085	5 way bottom entry
Special Features (28-30)	
EP	Electropolished
G...	Internal surface finish (G24, G32)
Valve Special Stem Seals	
HC	High Cycle service
AAX	FDA compliant stem seal. TFM thrust bearing and X shape gasket
PPX	CF PTFE thrust and X shape gasket
CAX	PCTFE thrust and TFM X shape gasket
CPX	PCTFE thrust and CF PTFE X shape gasket

MULTIPORT FLOATING BALL

Ball Types

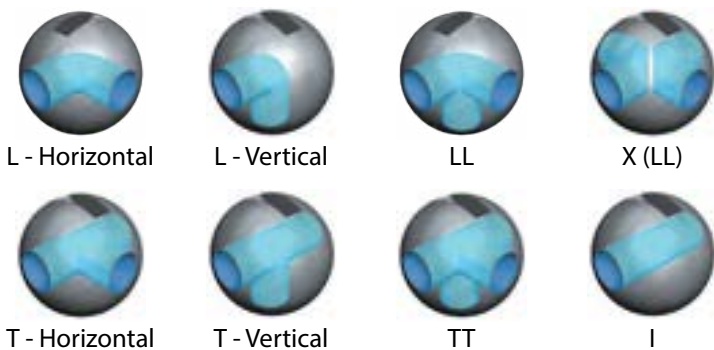

Seats & body seals

The 61/62 series valves have 4 seats that provide enhanced sealing characteristics. The seats are inserted into a support ring which is sealed with 2 separate body seals - 1 seal between the support ring and the body and the other between the support ring and the end connector. Both body seals are encapsulated and thus provide tighter compression of the seal for higher pressure & temperature fluctuations.

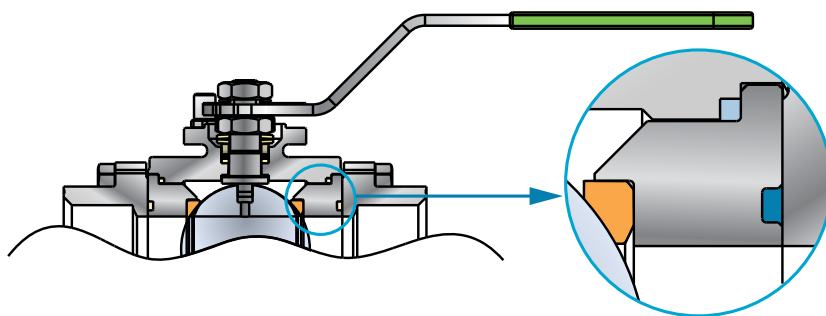

How to Use the Valve Selection

1. Select the valve type
3 Way Valve - Side Entry



2. Select the ball type
T - Horizontal



3. Select the rotation angle



4. Select the rotation direction (ccw/cw)



5. Select the starting position and flow pattern
Flow is indicated by a blue pipeline

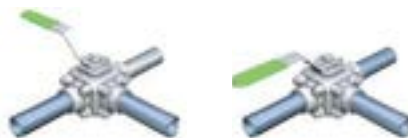

6. Use the flow pattern code number to order the appropriate valve

90°	CCW ◯	
	# 001	# 002
Start		





3 Way Valve | Side Entry 61

90°	CCW ⦿				CW ⦿			
	# 001	# 002	# 003	# 004	# 005	# 006	# 007	# 008
Start								
2 nd								

180°	CCW ⦿				CW ⦿			
	# 009	# 010	# 011	# 012	# 013	# 014	# 015	# 016
Start								
2 nd								
3 rd								

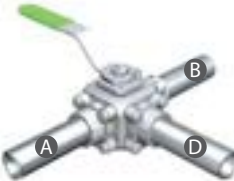
360°	CCW ⦿	CW ⦿
	# 017	# 018
Start		
2 nd		
3 rd		
4 nd		





T - Horizontal

MULTIPORT FLOATING BALL

3 Way Valve | Side Entry 61

90°	CCW ◯			CW ◯		
	# 019	# 020	# 021	# 022	# 023	# 024
Start						
2 nd						



180°	CCW ◯		CW ◯	
	# 025	# 026	# 027	# 028
Start				
2 nd				
3 rd				







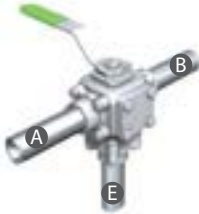

L - Horizontal

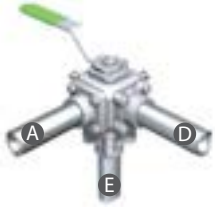
3 Way Valve | Bottom Entry D61

90°	CCW ◯			LL
	# 029			
Start				
2 nd				

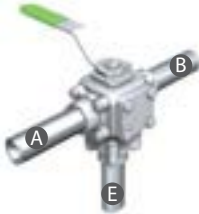
90°	CCW ◯			L - Vertical
	# 031			
Start				
2 nd				

180°	CCW ◯			L - Vertical
	# 030			
Start				
2 nd				
3 rd				



4 Way Valve | Bottom Entry D61

90°	CCW ⌚				CW ⌚			
	# 032	# 033	# 034	# 035	# 036	# 037	# 038	# 039
Start								
2 nd								
180°	CCW ⌚				CW ⌚			
	# 040	# 041	# 042	# 043	# 044	# 045	# 046	# 047
Start								
2 nd								
3 rd								
360°	CCW ⌚	CW ⌚						
	# 048	# 049						
Start								
2 nd								
3 rd								
4 th								

MULTIPORT FLOATING BALL

4 Way Valve | Bottom Entry D61

90°	CW ○ # 050
Start	
2 nd	

180°	CCW ○				CW ○			
	# 051	# 052	# 053	# 054	# 055	# 056	# 057	# 058
Start								
2 nd								
3 rd								

360°	CCW ○	CW ○
	# 059	# 060
Start		
2 nd		
3 rd		
4 th		

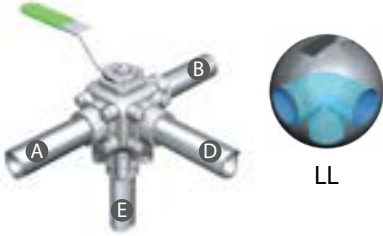



4 Way Valve | Bottom Entry D61

90°	CCW ◯ # 061
Start	
2 nd	

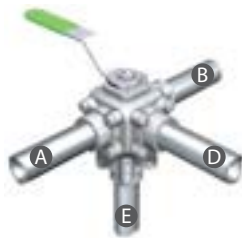

T - Vertical

360°	CCW ◯	CW ◯
	# 062	# 063
Start		
2 nd		
3 rd		
4 th		

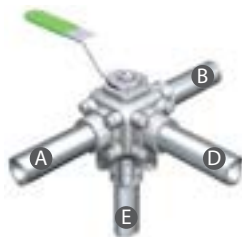

L - Vertical

4 Way Valve | Side Entry 62

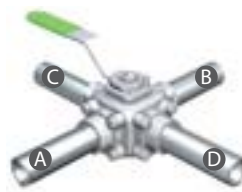

T - Horizontal

90°	CCW ◯	CW ◯	180° 2 positions	CW ◯	180° 3 positions	CCW ◯	CW ◯
	# 064	# 065		# 066		# 067	# 068
Start			Start		Start		
2 nd			2 nd		2 nd		
					3 rd		

MULTIPORT FLOATING BALL

4 Way Valve | Side Entry 62

180°	CCW ○ # 069
Start	
2 nd	

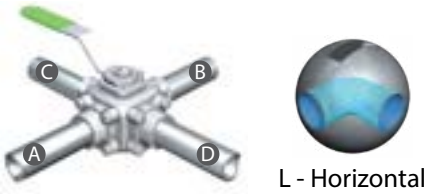

360°	CCW ○ # 070	CW ○ # 071
Start		
2 nd		
3 rd		
4 th		

90°	CCW ○ # 072
Start	
2 nd	

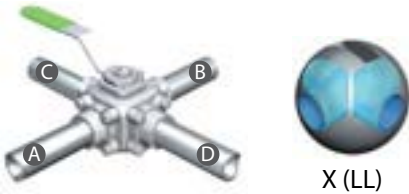

90°	CCW ○ # 073
Start	
2 nd	

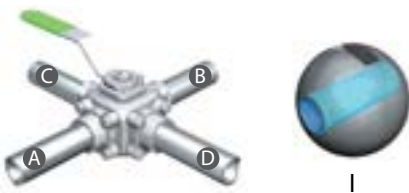



5 Way Valve - Bottom Entry D62

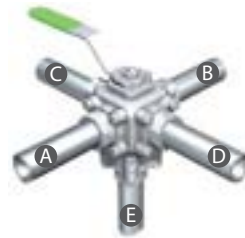

90°	CCW ○	CW ○
	# 074	# 075
Start		
2 nd		



TT - Horizontal

180°	CCW ○	CW ○
	# 076	# 077
Start		
2 nd		
3 rd		

360°	CCW ○	CW ○
	# 078	# 079
Start		
2 nd		
3 rd		
4 th		

90°	CCW ○
	# 080
Start	
2 nd	



T - Vertical

360°	CCW ○	CW ○
	# 081	# 082
Start		
2 nd		
3 rd		
4 th		



L - Vertical

180° 2 positions	CCW ○
	# 083
Start	
2 nd	



LL

360°	CCW ○	CW ○
	# 084	# 085
Start		
2 nd		
3 rd		
4 th		

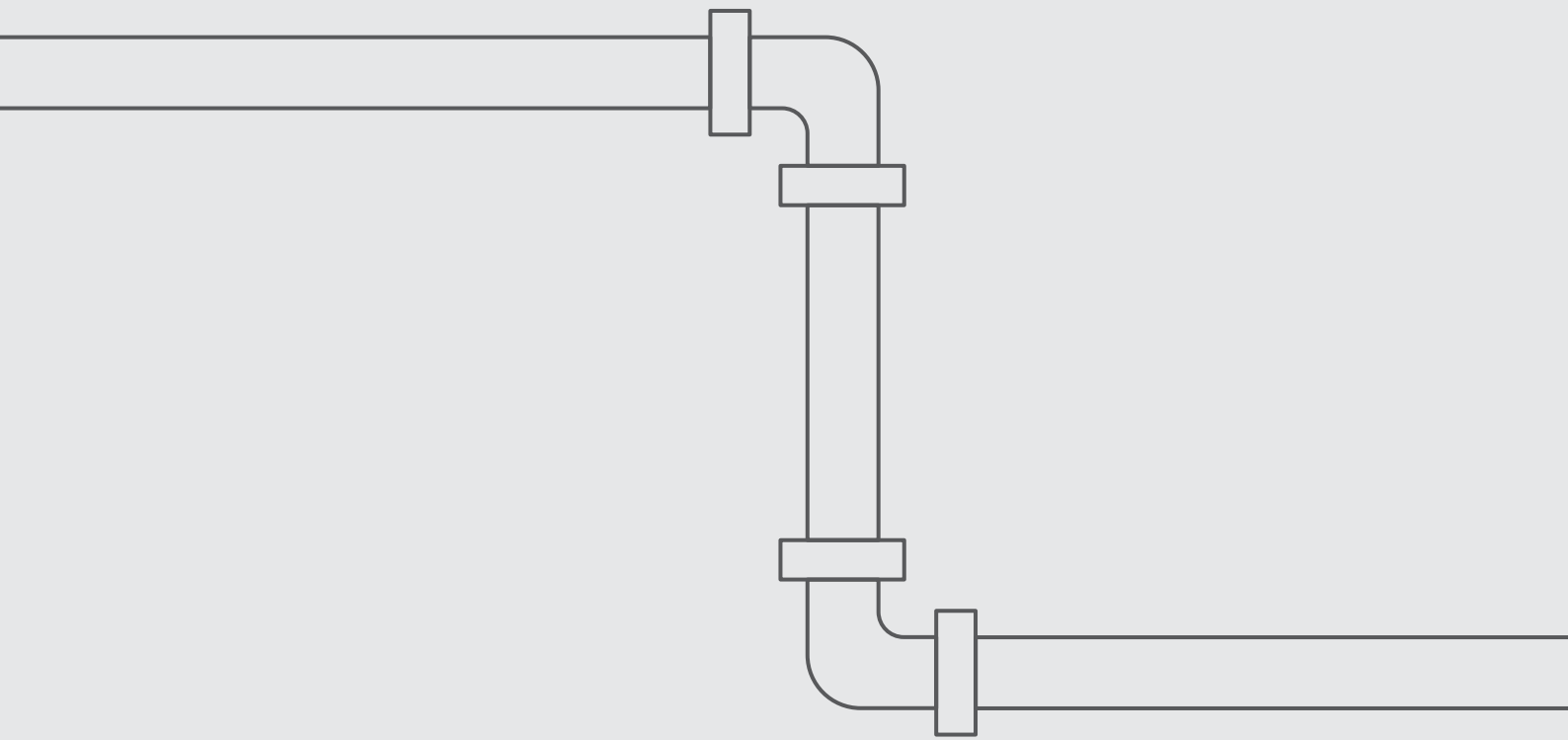

D47

S47



Industrial Valves

FLOATING BALL

DIVERTER
SIDE ENTRY
3 PIECE

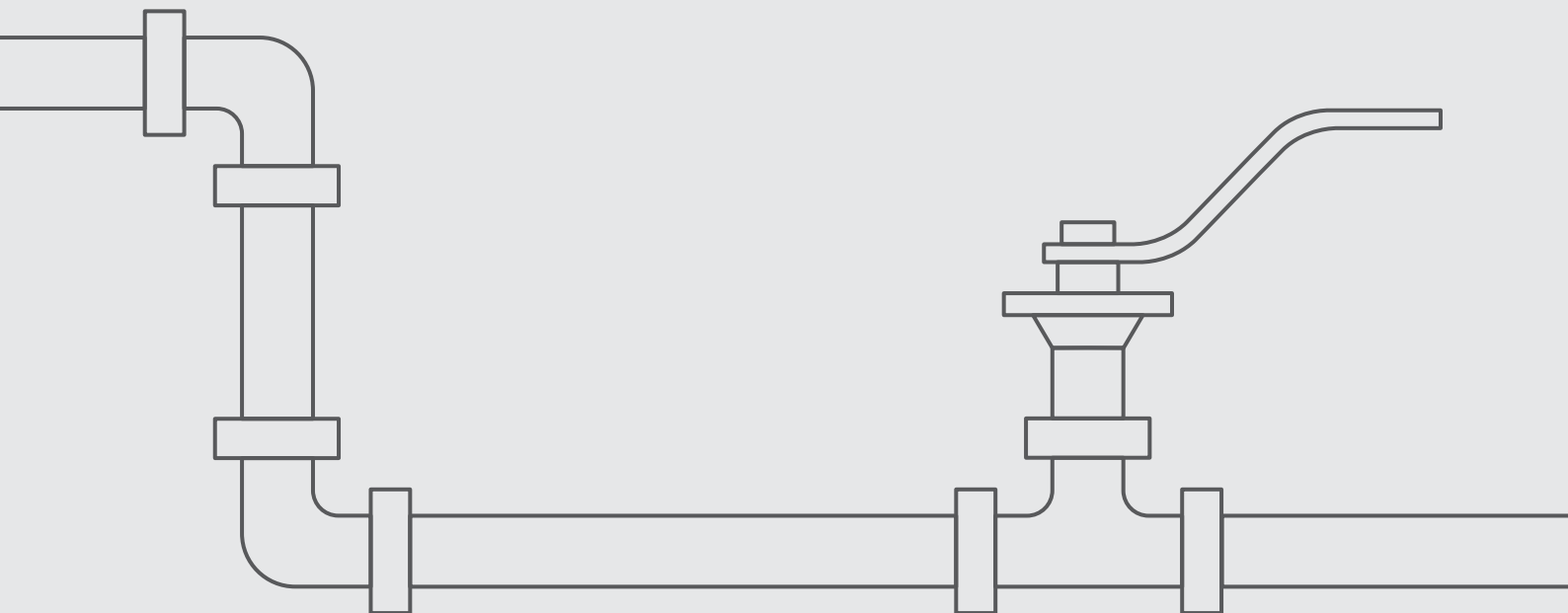

D47

S47

Diverter | Side Entry

Design features

Body

- Three piece design
- Forged or cast body
- Full compliance with ASME B16.34 (wall thickness)
- Easy in-line serviceable with swing-out body
- Large range of end connections for full or standard port valves
- Rugged top mounting platform compliant with ISO 5211 for easy mounting of actuator and other accessories

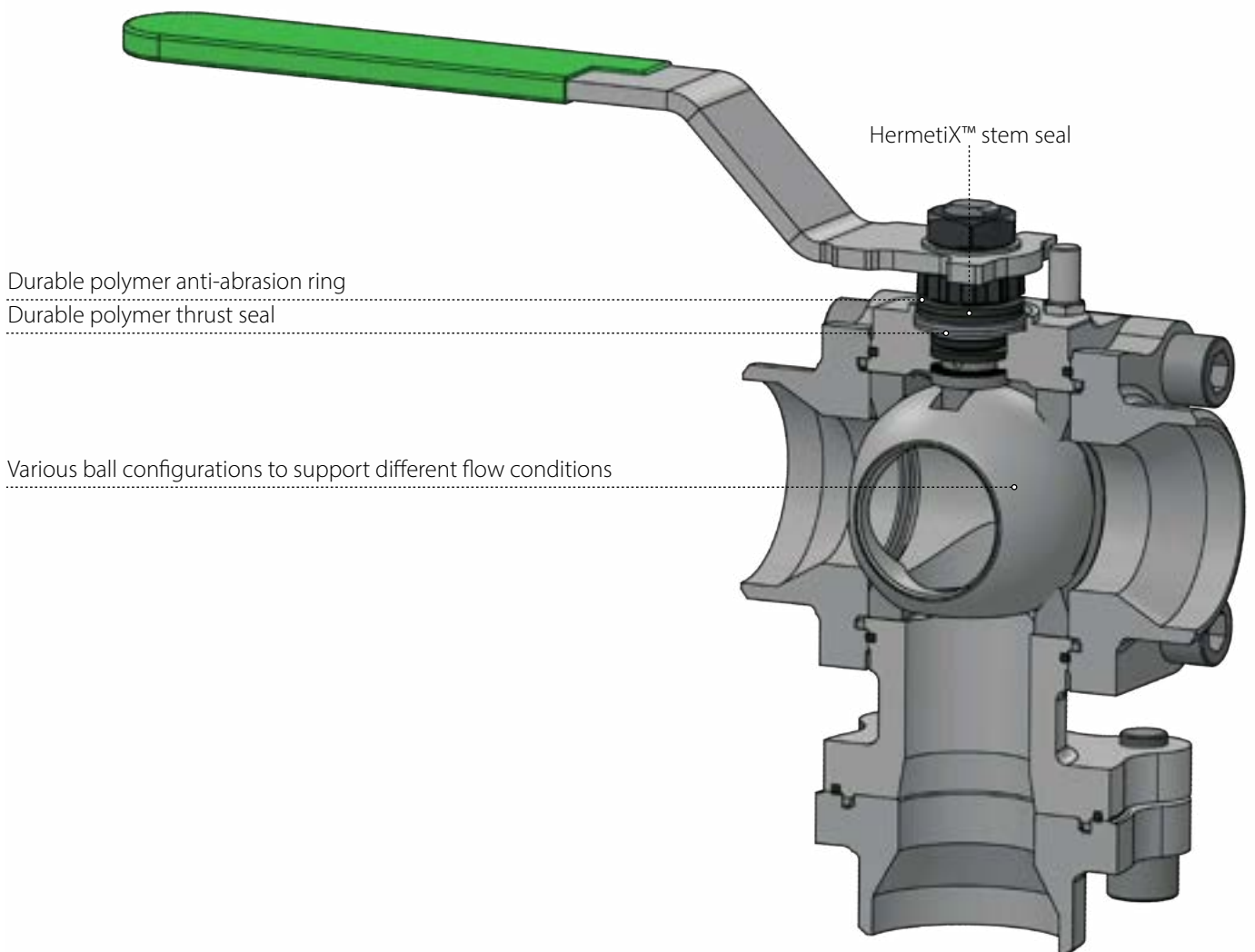

D47

S47



Side Entry - S47

Rotation: 90°

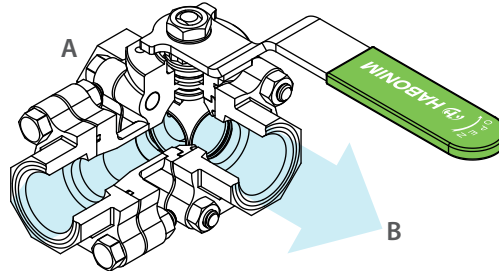
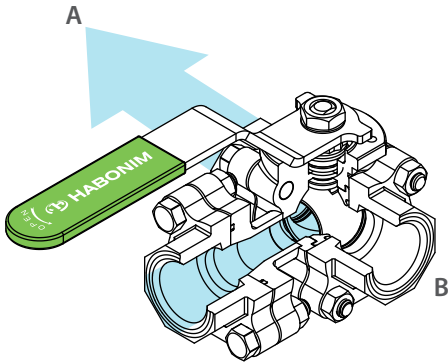

Bottom Entry - D47

Rotation: 90°

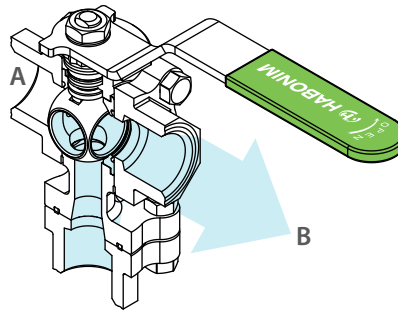
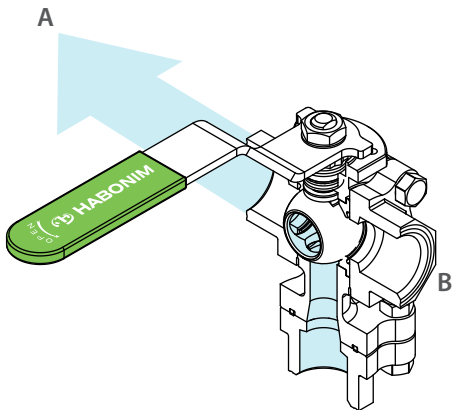

Bottom Entry - D47

Rotation: 180°

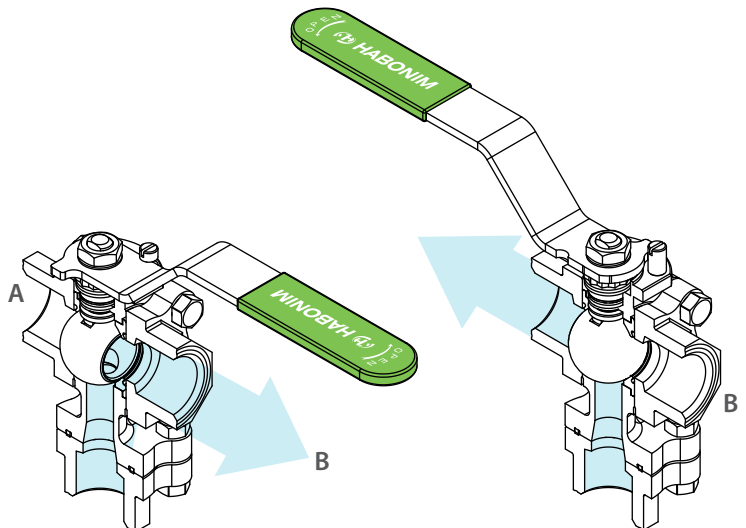
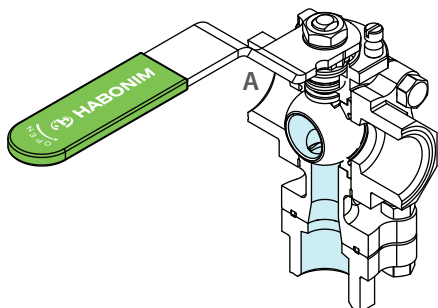

Diverter Floating Ball 3 Piece

Valve Dimensions

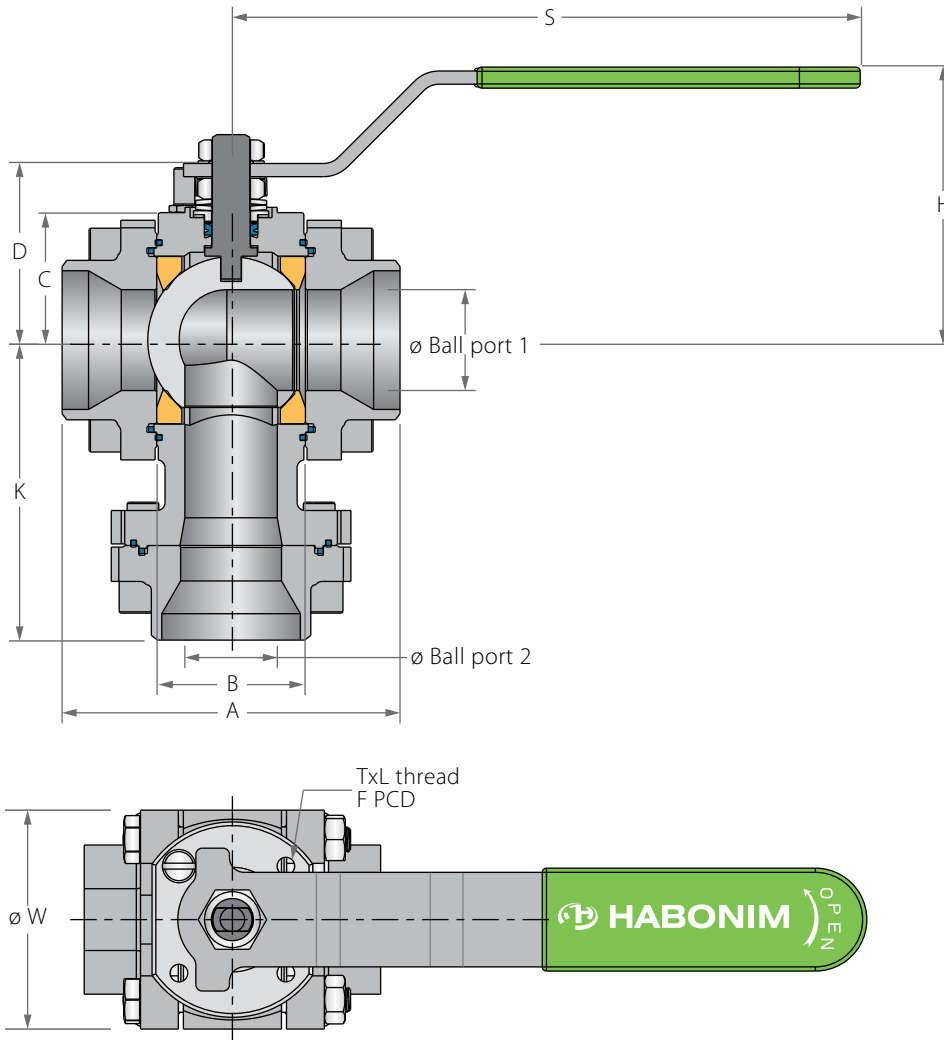

Preparation for actuation

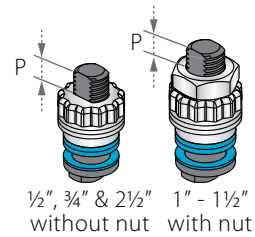

1/2", 3/4" & 2 1/2" without nut
1" - 1 1/2" with nut

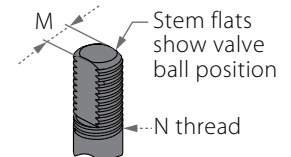

Stem flats show valve ball position

N thread

Std. port	Full port	Unit	Ball port1	Ball port2	A	B	C	D	H	K	S	W	M	N	P	F	TxL	Weight kg/lb	Kv Cv	
	DN8	mm	10.50	9.50	66.0	20.60	29.0	37.90	61.50	65.4	150.0	47.0	5.54	3/8" UNF	6.65	F03	36.0	M5X10	1.00	2.4
	1/4"	inch	0.41	0.37	2.60	0.81	1.14	1.49	2.42	2.57	5.91	1.85	0.22		0.26				1.42	2.20
	DN15	mm	10.50	9.50	66.0	20.60	29.0	37.90	61.50	65.4	150.0	47.0	5.54	3/8" UNF	6.65	F03	36.0	M5X10	1.00	2.8
	1/2"	3/8"	inch	0.41	0.37	2.60	0.81	1.14	1.49	2.42	2.57	5.91	1.85		0.22				0.26	1.42
	DN20	mm	14.30	11.90	70.60	24.50	31.40	40.30	63.90	70.6	150.0	53.70	5.54	3/8" UNF	6.65	F03	36.0	M5X10	1.20	4
	3/4"	1/2"	inch	0.56	0.47	2.78	0.97	1.24	1.59	2.52	2.78	5.91	2.11		0.22				0.26	1.42
	DN25	mm	20.60	15.90	93.70	31.70	38.10	55.60	79.40	119.0	187.0	63.70	7.54	7/16" UNF	7.40	F04	42.0	M5X10	2.40	8
	1"	3/4"	inch	0.81	0.63	3.69	1.25	1.50	2.19	3.13	3.46	7.36	2.51		0.30				0.29	1.65
	DN32	mm	25.40	20.50	108.0	41.30	42.70	60.20	84.10	97.0	187.0	71.70	7.54	7/16" UNF	7.40	F04	42.0	M5X10	4.00	16
	1 1/4"	1"	inch	1.0	0.81	4.25	1.62	1.68	2.37	3.31	3.81	7.36	2.82		0.30				0.29	1.65
	DN40	mm	31.80	26.60	115.50	48.40	43.60	73.0	97.0	105.50	237.0	86.70	8.71	9/16" UNF	8.50	F05	50.0	M6X12	5.50	40
	1 1/2"	1 1/4"	inch	1.25	1.05	4.55	1.91	1.72	2.87	3.82	4.15	9.33	3.41		0.34				0.33	1.97
	DN50	mm	38.10	35.0	128.0	56.30	48.30	77.80	101.80	113.5	237.0	96.90	8.71	9/16" UNF	8.50	F05	50.0	M6X12	6.90	42
	2"	1 1/2"	inch	1.50	1.38	5.04	2.22	1.90	3.06	4.01	4.47	9.33	3.82		0.34				0.33	1.97
	DN65	mm	50.80	48.0	158.0	72.60	70.0	88.10	115.10	132.70	237.0	108.0	8.71	9/16" UNF	13.50	F07	70.0	M8X12	14.45	96
	2 1/2"	2"	inch	2.0	1.89	6.22	2.86	2.76	3.47	4.53	5.22	9.33	4.25		0.34				0.53	2.76



Diverter Floating Ball 3 Piece

Components & Materials

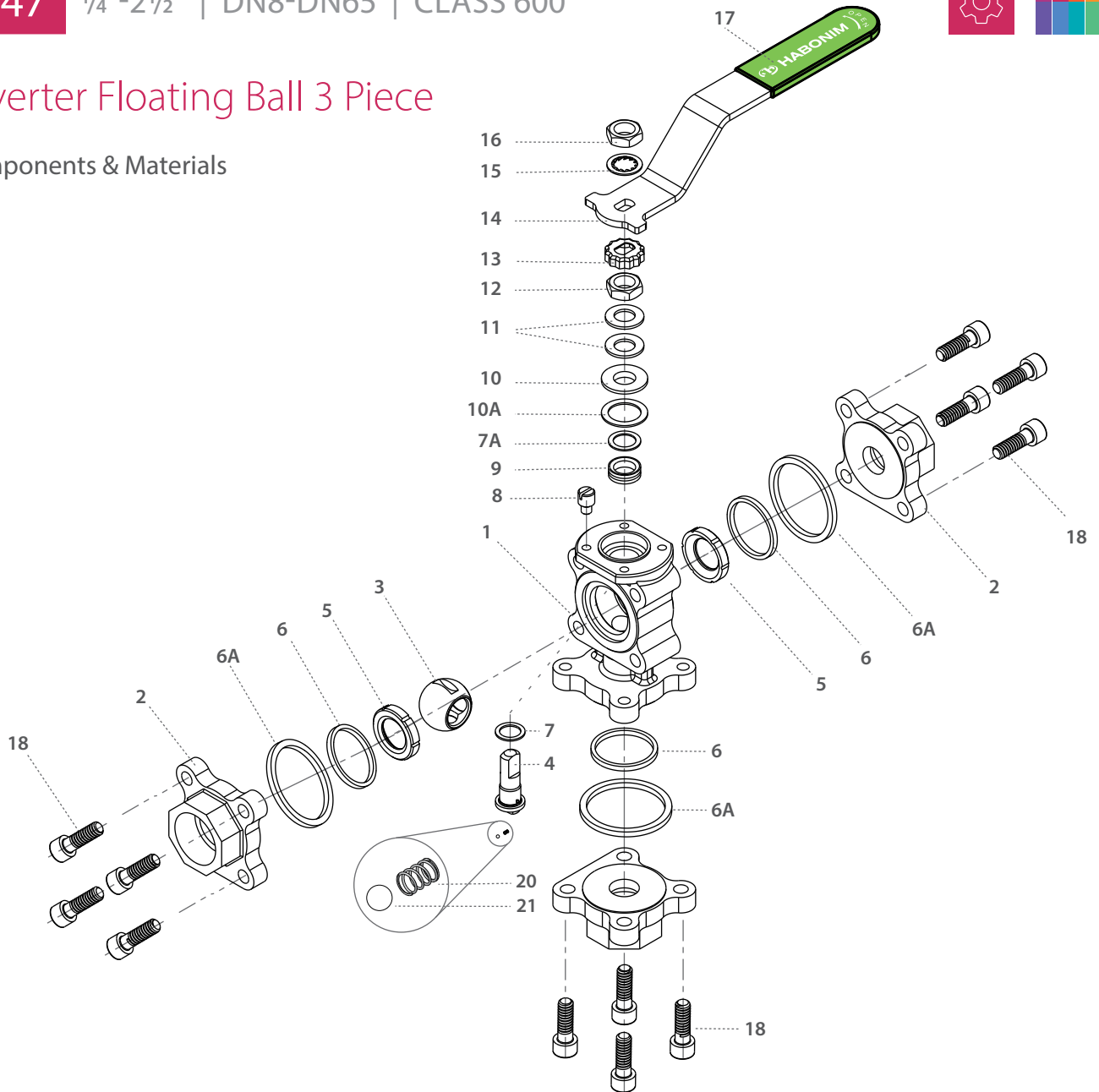

Item	Description	Material specification	Qty.
1	Body	Acc. Ordering Code	1
2	Ends	Acc. Ordering Code	3
3	Ball	Acc. Ordering Code	1
4	Stem	Acc. Ordering Code	1
5*	Seat	Acc. Ordering Code	2
6*	Body Seal	Acc. Ordering Code	3
6A*	Outer Seal	Acc. Ordering Code	3
7*	Stem Thrust Seal	PEEK, CF PEEK, PCTFE	1
7A*	Anti-Abrasion Ring	PEEK, CF PEEK, PCTFE	1
8	Stop Pin	S. Steel	1
9*	Stem Seal	CF PTFE, TFM	1
10	Follower	S. Steel	1

Item	Description	Material specification	Qty.
10A*	Slide Bearing	S. Steel	1
11	Disc Spring	S. Steel	2
12	Stem Nut	S. Steel	1
13	Locking Clip	S. Steel	1
14	Handle	S. Steel	1
15	Serrated Washer	S. Steel	1
16	Handle Nut	S. Steel	1
17	Sleeve	PVC	1
18	Body Bolt	S. Steel	12
20	Anti-Static Spring	S. Steel	1
21	Anti-Static Plunger	S. Steel	1
23	Tag (not shown)	S. Steel	1

* Maintenance kit components

Diverter Floating Ball 3 Piece

Valve Dimensions

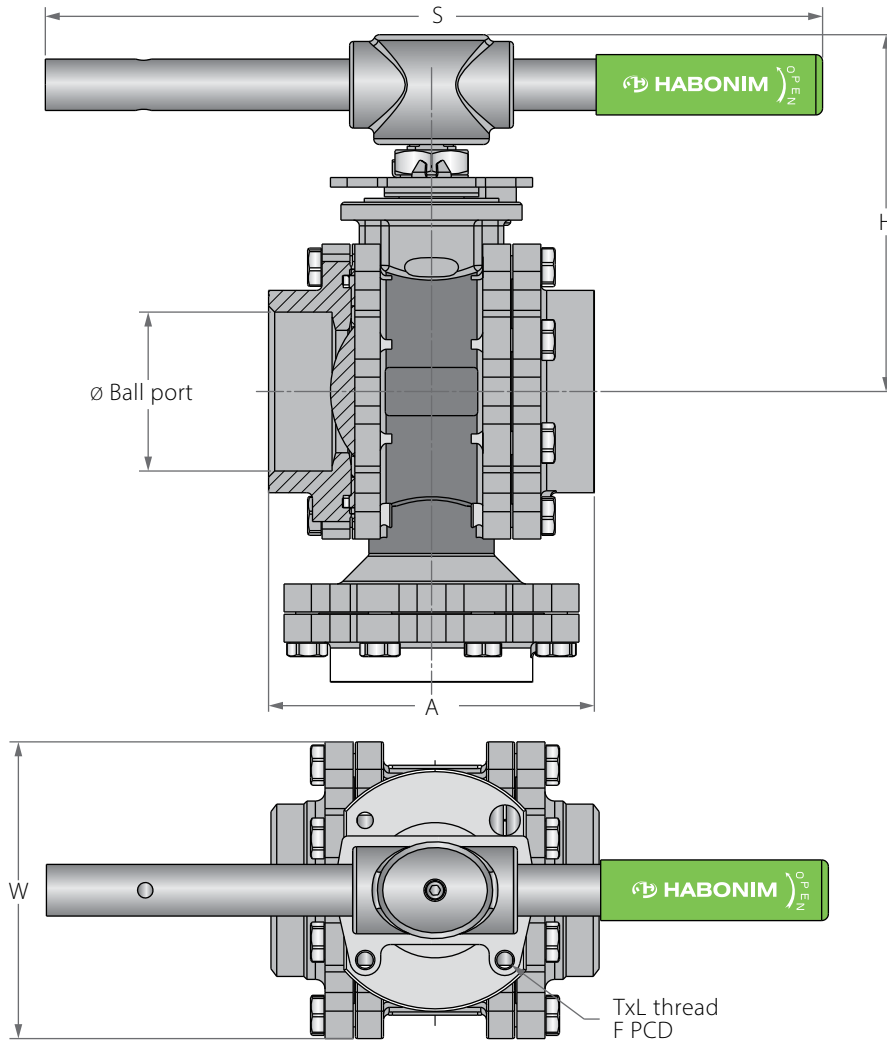

Preparation for actuation

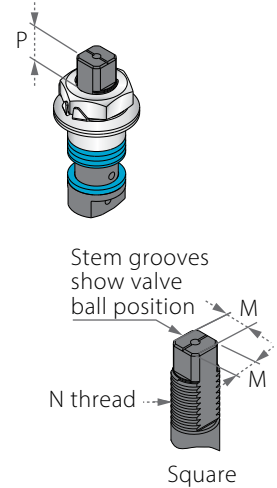

Std. port	Full port	Unit	Ball port 1	Ball port 2	A	B	C	D	H	K	S	W	M	N	P	F	TxL	Weight kg/lb	Kv Cv	
DN80	DN65	mm	63.75	80.50	169.0	83.3	98.3	144.9	185.0	163.0	400.0	18.90	15.90	1"-14	16.70	F10	102.0	M10x20	18.00	129
3"	2½"	inch	2.51	3.17	6.65	3.28	3.87	5.70	7.28	6.42	15.75	0.74	0.63	UNS-2A	0.66		4.02		39.67	150
DN100	DN80	mm	80.0	63.25	214.0	108.8	114.1	160.7	200.0	183.0	600.0	18.90	15.90	1"-14	16.70	F10	102.0	M10x20	28.20	182
4"	3"	inch	3.15	2.49	8.43	4.28	4.49	6.33	7.87	7.20	23.62	0.74	0.63	UNS-2A	0.66		4.02		62.15	211
	DN100	mm	92.0	67.0	239.0	123.0	124.0	170.5	211.0	200.0	600.0	18.90	15.90	1"-14	16.70	F10	102.0	M10x20	36.00	334
	4"	inch	3.62	2.64	9.41	4.84	4.88	6.71	8.31	7.87	23.62	0.74	0.63	UNS-2A	0.66		4.02		79.34	388
DN150		mm	111.35	77.90	346.0	146.0	157.0	226.0	286.0	212.0	916.0	28.45	23.75	1½"-12	26.20	F12	125.0	M12x20	41.00	437
6"		inch	4.38	3.07	13.62	5.75	6.18	8.90	11.26	8.35	36.06	1.12	0.94	UNF-2A	1.03		4.92		90.36	507



Diverter Floating Ball 3 Piece

Components & Materials

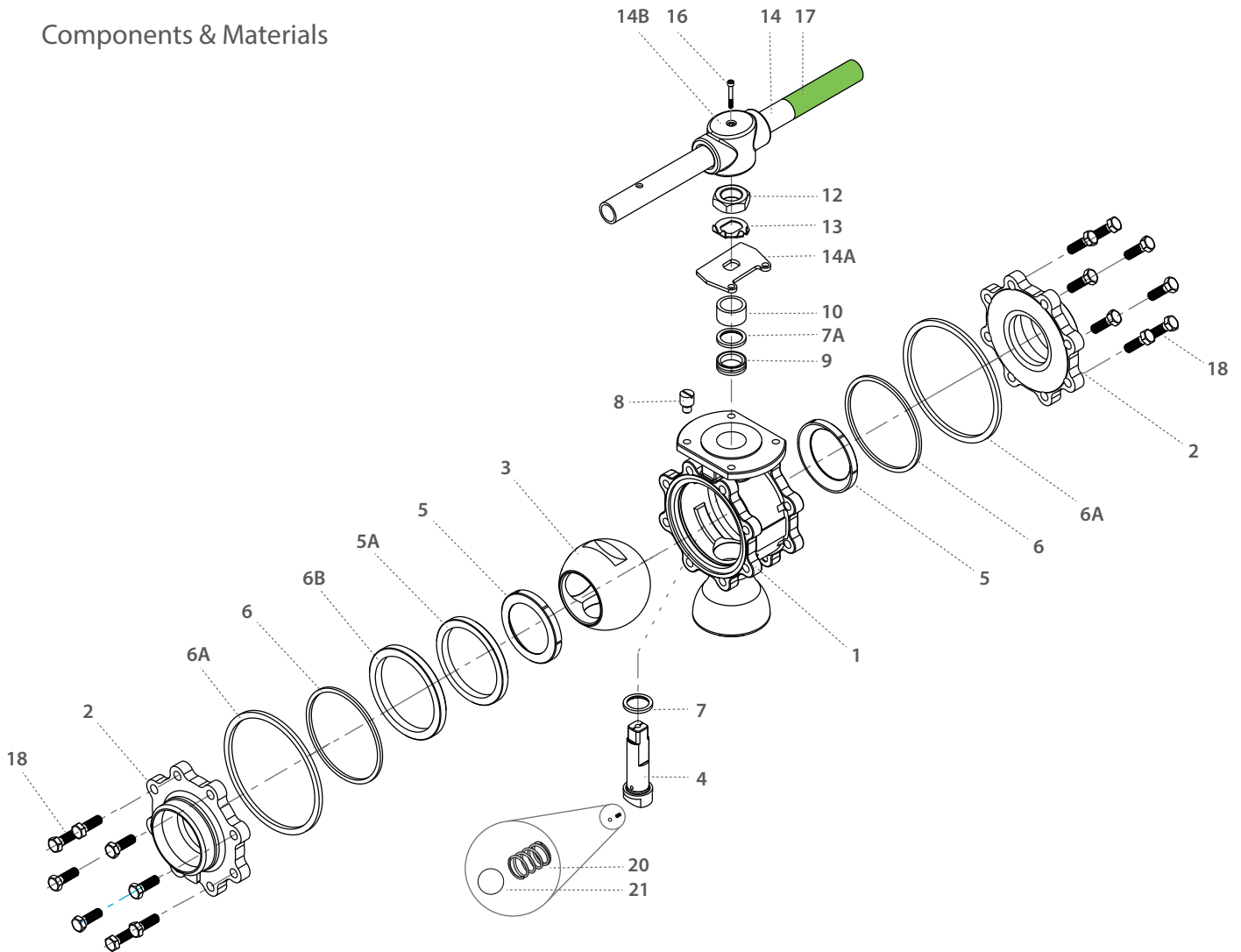

Item	Description	Material specification	Qty.
1	Body	Acc. Ordering Code	1
2	Plug	Acc. Ordering Code	1
3	Ball	Acc. Ordering Code	1
4	Stem	Acc. Ordering Code	1
5*	Seat	Acc. Ordering Code	2
6*	Body Seal	Acc. Ordering Code	2
6A*	Outer Seal	Acc. Ordering Code	2
6B	Support Ring	S. Steel	1
7*	Stem Thrust Seal	PEEK, CF PEEK, PCTFE	1
7A*	Anti-Abrasion Ring	PEEK, CF PEEK, PCTFE	1
8	Stop Pin	S. Steel	1
9*	Stem Seal	CF PTFE, TFM	1
10	Follower	S. Steel	1

Item	Description	Material specification	Qty.
11	Disc Spring	S. Steel	2
12	Stem Nut	S. Steel	1
13	Tab Lock Washer	S. Steel	1
14	Handle	S. Steel	1
14A	Stop Plate	S. Steel	1
14B	Wrench Head	S. Steel	1
16	Wrench Bolt	S. Steel	1
17	Sleeve	PVC	1
18	Body Bolt	S. Steel	16
20	Anti-Static Spring	S. Steel	2
21	Anti-Static Plunger	S. Steel	2
23	Tag (not shown)	S. Steel	1

* Maintenance kit components

Side Entry Floating Ball 3 Piece

Valve Dimensions

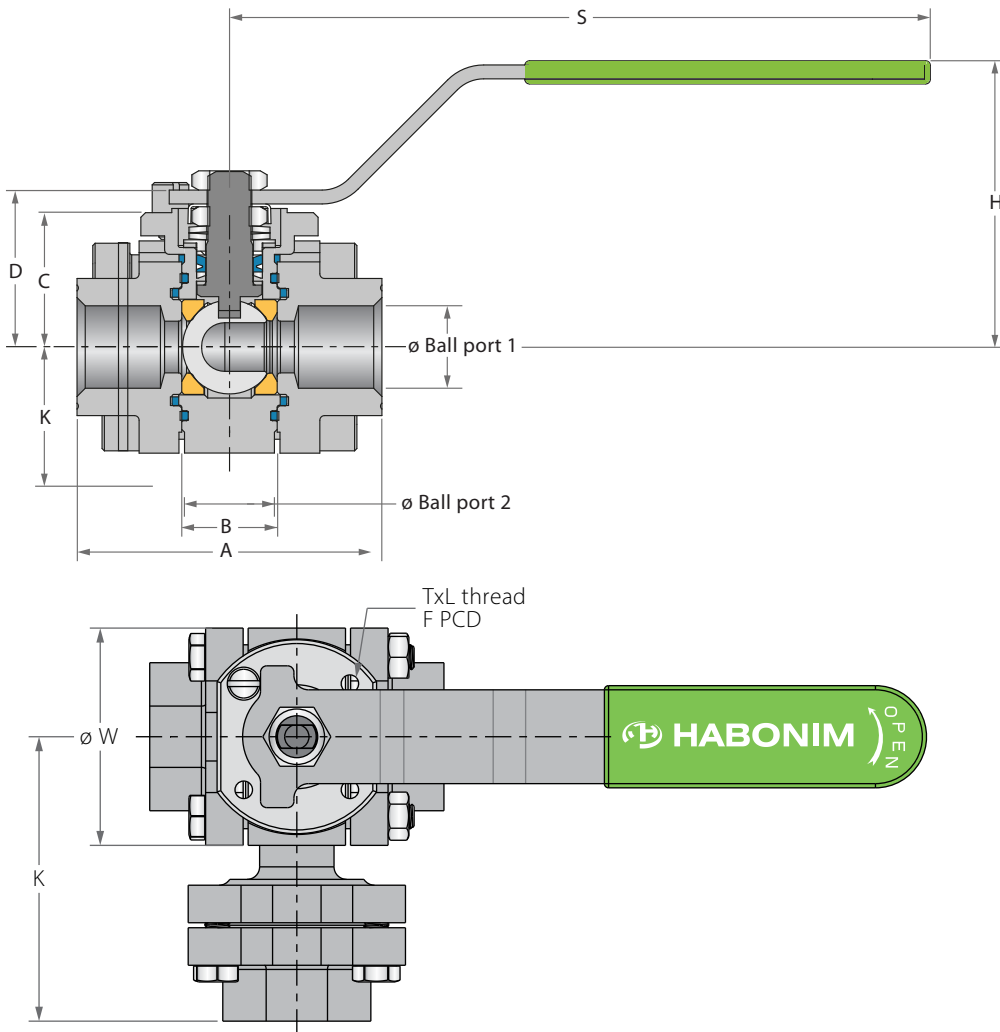

Preparation for actuation

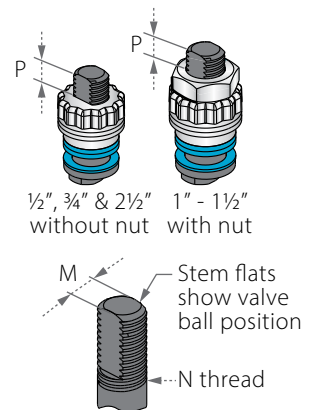

1/2", 3/4" & 2 1/2" without nut
1" - 1 1/2" with nut

Std. port	Full port	Unit	Ball port1	Ball port2	A	B	C	D	H	K	S	W	M	N	P	F	TxL	Weight kg/lb	Kv Cv	
	DN8	mm	10.50	9.50	66.0	20.60	29.0	37.90	61.50	88.20	150.0	47.0	5.54	3/8" UNF	6.65	F03	36.0	M5X10	1.00	2.4
	1/4"	inch	0.41	0.37	2.60	0.81	1.14	1.49	2.42	3.48	5.91	1.85	0.22		0.26		1.42		2.20	2.8
DN15	DN10	mm	10.50	9.50	66.0	20.60	29.0	37.90	61.50	88.20	150.0	47.0	5.54	3/8" UNF	6.65	F03	36.0	M5X10	1.00	2.8
1/2"	3/8"	inch	0.41	0.37	2.60	0.81	1.14	1.49	2.42	3.48	5.91	1.85	0.22		0.26		1.42		2.20	3.3
DN20	DN15	mm	14.30	11.90	70.60	24.50	31.40	40.30	63.90	93.70	150.0	53.70	5.54	3/8" UNF	6.65	F03	36.0	M5X10	1.20	4
3/4"	1/2"	inch	0.56	0.47	2.78	0.97	1.24	1.59	2.52	3.68	5.91	2.11	0.22		0.26		1.42		2.64	5
DN25	DN20	mm	20.60	15.90	93.70	31.70	38.10	55.60	79.40	119.0	187.0	63.70	7.54	7/16" UNF	7.40	F04	42.0	M5X10	2.40	8
1"	3/4"	inch	0.81	0.63	3.69	1.25	1.50	2.19	3.13	4.68	7.36	2.51	0.30		0.29		1.65		5.29	9
DN32	DN25	mm	25.40	20.50	108.0	41.30	42.70	60.20	84.10	130.15	187.0	71.70	7.54	7/16" UNF	7.40	F04	42.0	M5X10	4.00	16
1 1/4"	1"	inch	1.0	0.81	4.25	1.62	1.68	2.37	3.31	5.13	7.36	2.82	0.30		0.29		1.65		8.82	19
DN40	DN32	mm	31.80	26.60	115.50	48.40	43.60	73.0	97.0	139.05	237.0	86.70	8.71	9/16" UNF	8.50	F05	50.0	M6X12	5.50	40
1 1/2"	1 1/4"	inch	1.25	1.05	4.55	1.91	1.72	2.87	3.82	5.47	9.33	3.41	0.34		0.33		1.97		12.12	46
DN50	DN40	mm	38.10	35.0	128.0	56.30	48.30	77.80	101.80	149.45	237.0	96.90	8.71	9/16" UNF	8.50	F05	50.0	M6X12	6.90	42
2"	1 1/2"	inch	1.50	1.38	5.04	2.22	1.90	3.06	4.01	5.88	9.33	3.82	0.34		0.33		1.97		15.21	49
DN65	DN50	mm	50.80	48.0	158.0	72.60	70.0	88.10	115.10	175.40	237.0	108.0	8.71	9/16" UNF	13.50	F07	70.0	M8X12	14.45	96
2 1/2"	2"	inch	2.0	1.89	6.22	2.86	2.76	3.47	4.53	6.90	9.33	4.25	0.34		0.53		2.76		31.85	111



Side Entry Floating Ball 3 Piece

Components & Materials

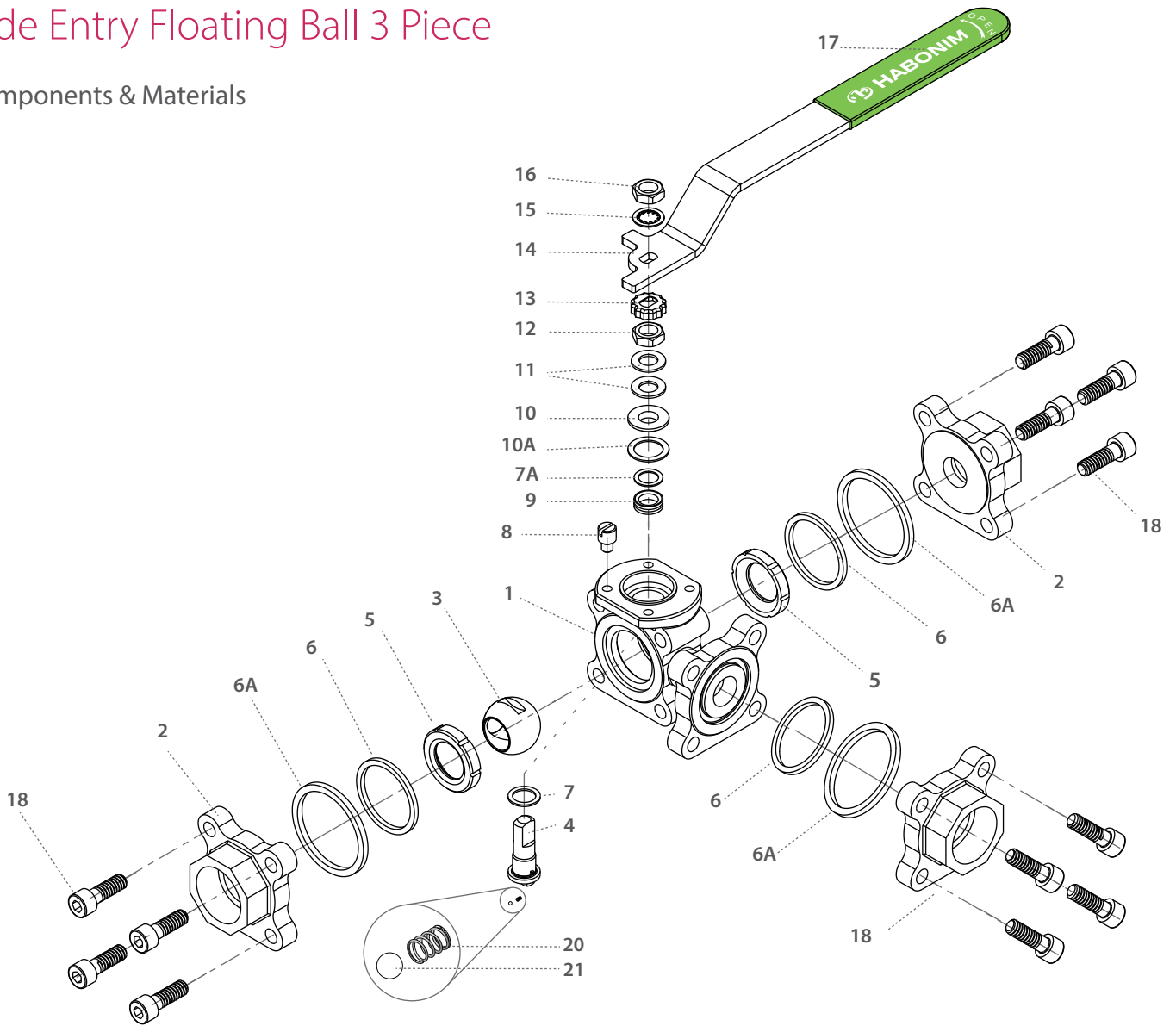

Item	Description	Material specification	Qty.
1	Body	Acc. Ordering Code	1
2	Ends	Acc. Ordering Code	3
3	Ball	Acc. Ordering Code	1
4	Stem	Acc. Ordering Code	1
5*	Seat	Acc. Ordering Code	2
6*	Body Seal	Acc. Ordering Code	3
6A*	Outer Seal	Acc. Ordering Code	3
7*	Stem Thrust Seal	PEEK, CF PEEK, PCTFE	1
7A*	Anti-Abrasion Ring	PEEK, CF PEEK, PCTFE	1
8	Stop Pin	S. Steel	1
9*	Stem Seal	CF PTFE, TFM	1
10	Follower	S. Steel	1

Item	Description	Material specification	Qty.
10A*	Slide Bearing	S. Steel	1
11	Disc Spring	S. Steel	2
12	Stem Nut	S. Steel	1
13	Locking Clip	S. Steel	1
14	Handle	S. Steel	1
15	Serrated Washer	S. Steel	1
16	Handle Nut	S. Steel	1
17	Sleeve	PVC	1
18	Body Bolt	S. Steel	4
20	Anti-Static Spring	S. Steel	1
21	Anti-Static Plunger	S. Steel	1
23	Tag (not shown)	S. Steel	1

* Maintenance kit components

Side Entry Floating Ball 3 Piece

Valve Dimensions

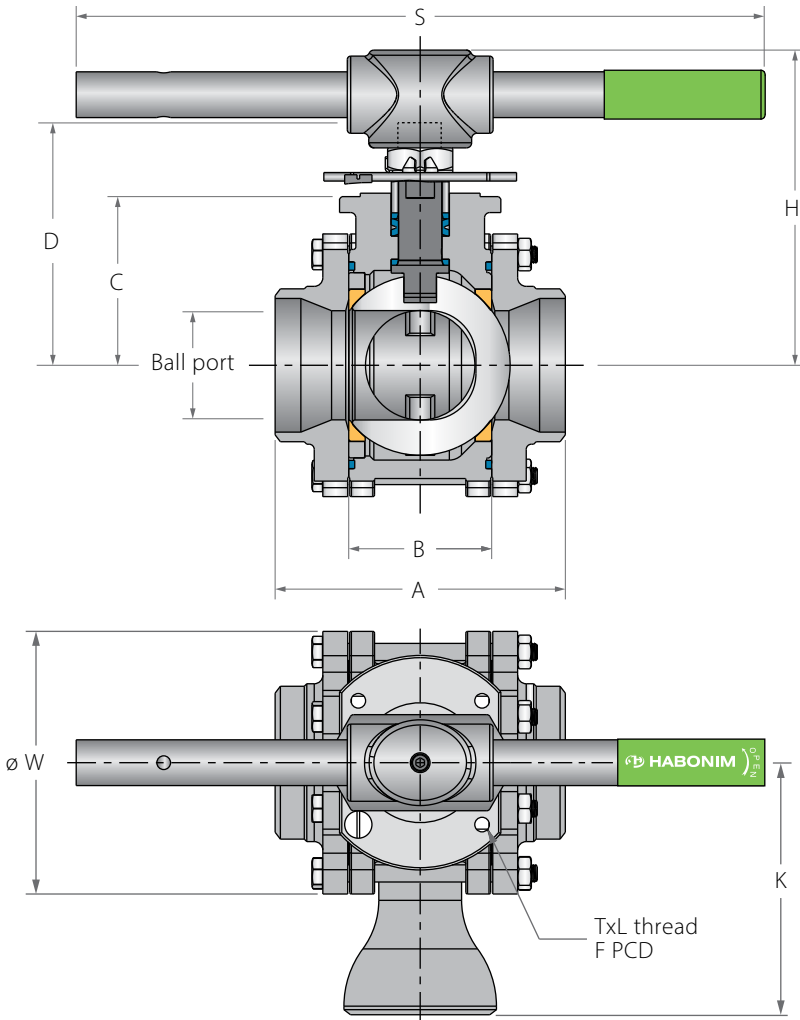

Preparation for actuation

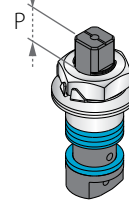

Stem grooves show valve ball position

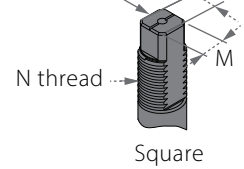

Std. port	Full port	Unit	Ball port 1	Ball port 2	A	B	C	D	H	K	S	W	M	N	P	F	TxL	Weight kg/lb	Kv Cv	
DN80	DN65	mm	63.75	80.50	169.0	83.3	98.3	144.9	185.0	163.0	400.0	140.0	18.90	1"-14	16.70	F10	102.0	M10x20	18.00	129
3"	2½"	inch	2.51	3.17	6.65	3.28	3.87	5.70	7.28	6.42	15.75	5.50	0.74	UNS-2A	0.66		4.02		39.67	150
DN100	DN80	mm	80.0	63.25	214	108.8	114.1	160.7	200.0	183.0	600.0	177.0	18.90	1"-14	16.70	F10	102.0	M10x20	28.20	182
4"	3"	inch	3.15	2.49	8.43	4.28	4.49	6.33	7.87	7.20	23.62	6.97	0.74	UNS-2A	0.66		4.02		62.15	211
	DN100	mm	92.0	67.0	239.0	123.0	124.0	170.5	211.0	200.0	600.0	217.0	18.90	1"-14	16.70	F10	102.0	M10x20	36.00	334
	4"	inch	3.62	2.64	9.41	4.84	4.88	6.71	8.31	7.87	23.62	8.54	0.74	UNS-2A	0.66		4.02		79.34	388
DN150		mm	111.35	77.90	346.0	146.0	157.0	226.0	286.0	212.0	916.0	266.0	28.45	1½"-12	26.20	F12	125.0	M12x20	41.00	437
6"		inch	4.38	3.07	13.62	5.75	6.18	8.90	11.26	8.35	36.06	10.47	1.12	UNF-2A	1.03		4.92		90.36	507



Side Entry Floating Ball 3 Piece

Components & Materials

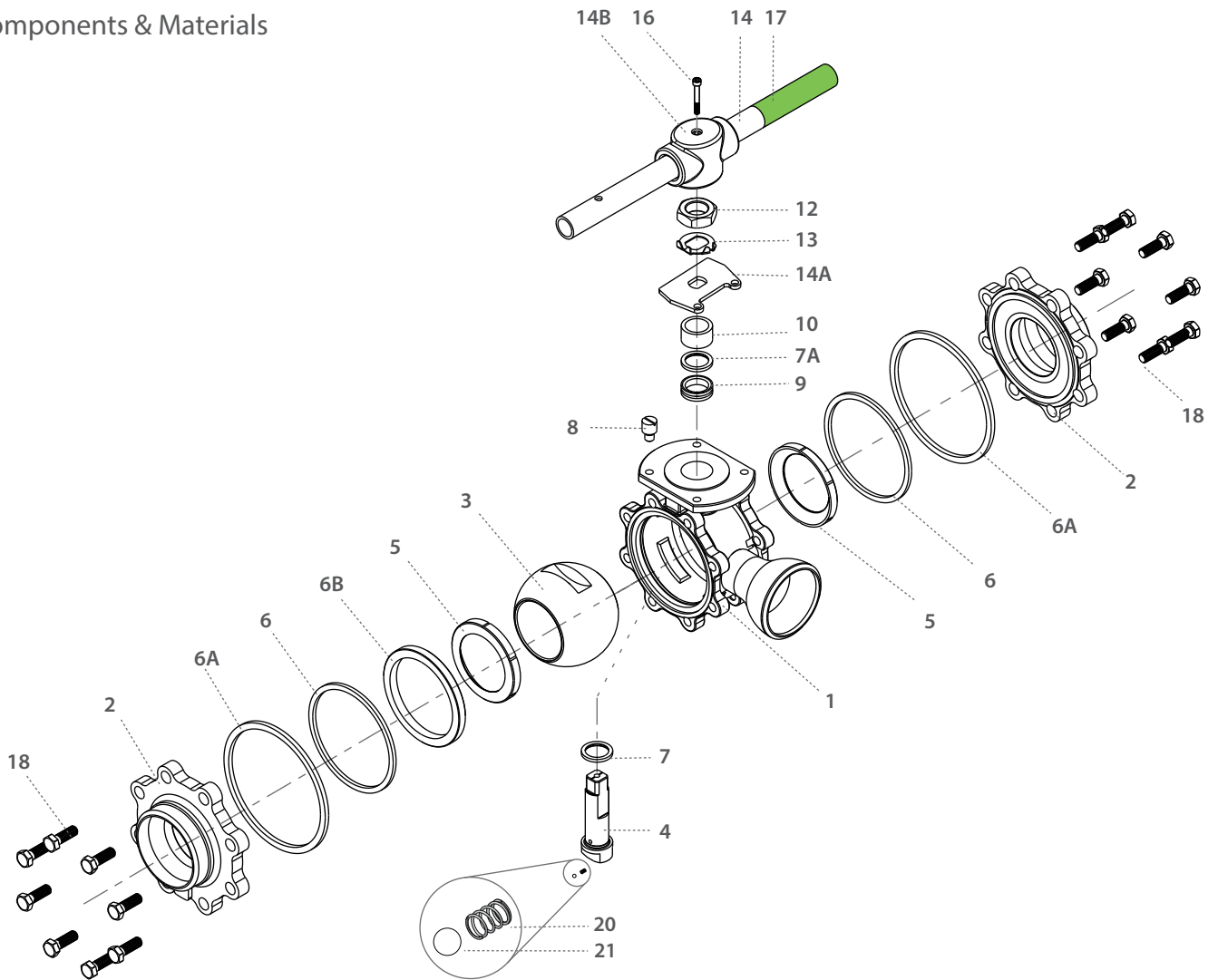

Item	Description	Material specification	Qty.
1	Body	Acc. Ordering Code	1
2	Plug	Acc. Ordering Code	1
3	Ball	Acc. Ordering Code	1
4	Stem	Acc. Ordering Code	1
5*	Seat	Acc. Ordering Code	2
6*	Body Seal	Acc. Ordering Code	1
6A*	Outer Seal	Acc. Ordering Code	2
6B	Support Ring	Acc. Ordering Code	2
7*	Stem Thrust Seal	PEEK, CF PEEK, PCTFE	1
7A*	Anti-Abrasion Ring	PEEK, CF PEEK, PCTFE	1
8	Stop Pin	Acc. Ordering Code	1
9*	Stem Seal	CF PTFE, TFM, Graphite	1
10	Follower	S. Steel	1

Item	Description	Material specification	Qty.
11	Disc Spring	S. Steel	2
12	Stem Nut	S. Steel	1
13	Tab Lock Washer	S. Steel	1
14	Handle	S. Steel	1
14A	Stop Plate	S. Steel	1
14B	Wrench Head	S. Steel	1
16	Wrench Bolt	S. Steel	1
17	Sleeve	PVC	1
20	Antistatic Spring	S. Steel	2
21	Antistatic Plunger	S. Steel	2
23	Tag (not shown)	S. Steel	1

* Maintenance kit components



Diverter | Side Entry 3 Piece - Ordering Code System

"Mandatory option" options are marked with **green background** | "Standard offer" options are marked with **light green background**

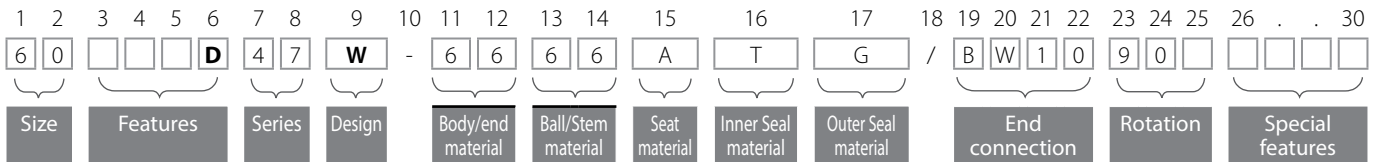

Size (1-2)		
Code	inch	mm
02	¼"	8
03	⅜"	10
05	½"	15
07	¾"	20
10	1"	25
12	1¼"	32
15	1½"	40
20	2"	50
25	2½"	65
30	3"	80
40	4"	100
60	6"	150

Features (3-6)	
D	Diverter bottom entry
S	3 piece Side entry
B	Full port
O	Clean assembly for O2 service
K	Chlorine service
F	Shell only - fire safe
H*	Hydrogen service

* for material selection - see Hydrogen Service chapter

Series (7-8)	
D47	3 piece bottom entry
S47	3 piece side entry

Design (9)	
W	Total HermetiX Integrity package

Body/Ends material (11-12)	
6	S. SteelCF8M/CF3M*
1	Bronze
4	C. steel A216 WCB/A105
9	C. steel A352 LCB
7	Monel
A	Alloy-20
W	Alloy-C22
D	Duplex A479
K	Super Duplex A479
S	254SMO A479

Ball material (13)	
6	S. SteelCF8M/316
W	Hastelloy-C22
S	254SMO
D	Duplex
1	Bronze
K	Super Duplex
7	Monel
A	Alloy-20
C	Hastelloy-C276

Stem material (14)	
6	S. Steel316
M	High Strength S. Steel
Z	Inconel 718
W	Alloy-C22
S	254SMO A479
A	Alloy-20
D	Duplex A479
K	Super Duplex A479
7	Monel
C	Hastelloy-C276

Seat material (15)	
A	TFM(3)
U	UHMWPE
T	PTFE(3)
P	CF PTFE(3)
C	PCTFE
K	CF PEEK
L	Virgin Peek
Y	Delrin
W	PVDF
R	15% Glass filled PTFE

Inner Seal Material (16)	
T	PTFE
A	TFM
U	UHMWPE
V	Viton
B	NBR
G	Expanded graphite

Outer Seal Material (17)	
G	Expanded graphite
A	TFM

End Connection (19-22)	
Welded ends	
BW10	Buttweld schd. 10
BW	Buttweld schd. 40
SW	Socket weld
XBW10	Extended buttweld schd. 10
XBW	Extended buttweld schd. 40
XSW	Extended socket weld
BW5	Buttweld schd. 5
BW80	Buttweld schd. 80
BWO*	Buttweld tube OD
BWD	Buttweld DIN 11850
BWI1.6	Buttweld ISO 1127 1.6mm
BWI2.0	Buttweld ISO 1127 2.0mm
BWI2.3	Buttweld ISO 1127 2.3mm
SWO*	Socket weld tube OD
ETO*	Extended tube OD
ETI1.6	Extended buttweld ISO 1127 1.6mm
ETI2.0	Extended buttweld ISO 1127 2.0mm
ETI2.3	Extended buttweld ISO 1127 2.3mm
ETD	Extended buttweld DIN 11850

Threaded	
NPT	ASME B1.20.1 - National Pipe Taper thread
BSPT	EN 10226 - Pipe Taper thread
BSPP	ISO228-1, DIN3852 - Pipe Parallel thread
DIN3852	DIN3852 - Pipe Parallel thread
AS5202	SAE internal straight thread
MNPT	Male NPT
MBSPT	Male BSPT

Flanged	
150	ASME B16.5 #150 RF
300	ASME B16.5 #300 RF
600	ASME B16.5 #600 RF
900	ASME B16.5 #900 RF
PN16	EN1092 PN16 RF
PN40	EN1092 PN40 RF
PN63	EN1092 PN63 RF
PN100	EN1092 PN100 RF
PN160	EN1092 PN160 RF

Clamp	
LL*	Compression fitting (Imperial) - No Nuts & Ferrules
LM*	Compression fitting (metric) - No Nuts & Ferrules
LL-NF*	Compression fitting (Imperial) - with Nuts & Ferrules
LM-NF*	Compression fitting (metric) - with Nuts & Ferrules
TC*	Tri-Clamp
GR**	Grayloc® compatible hub (Grayloc® is a registered trademark of Grayloc Products, L.L.C.)

Rotation (23 -25)	
90	90 degrees rotation
180	180 degrees rotation applicable for bottom entry diverter valve L

Special Features (24-30)	
B	Body made from rolled bar
EP	Electropolished
WR	DD stem
G...	Internal surface finish (G24, G32)

Valve Special Stem Seals	
AAX	FDA compliant stem seal.
PPX	CF PTFE thrust and X shape gasket
CAX	PCTFE thrust and TFM X shape gasket
CPX	PCTFE thrust and CF PTFE X shape gasket
HC	High Cycle service

* CF3M - for welded ends only.

* Std. port only

** Not available for 1¼" (DN32) Valves

D31

S31

D32

S32



Industrial Valves

FLOATING BALL

DIVERTER
SIDE ENTRY
FLANGED

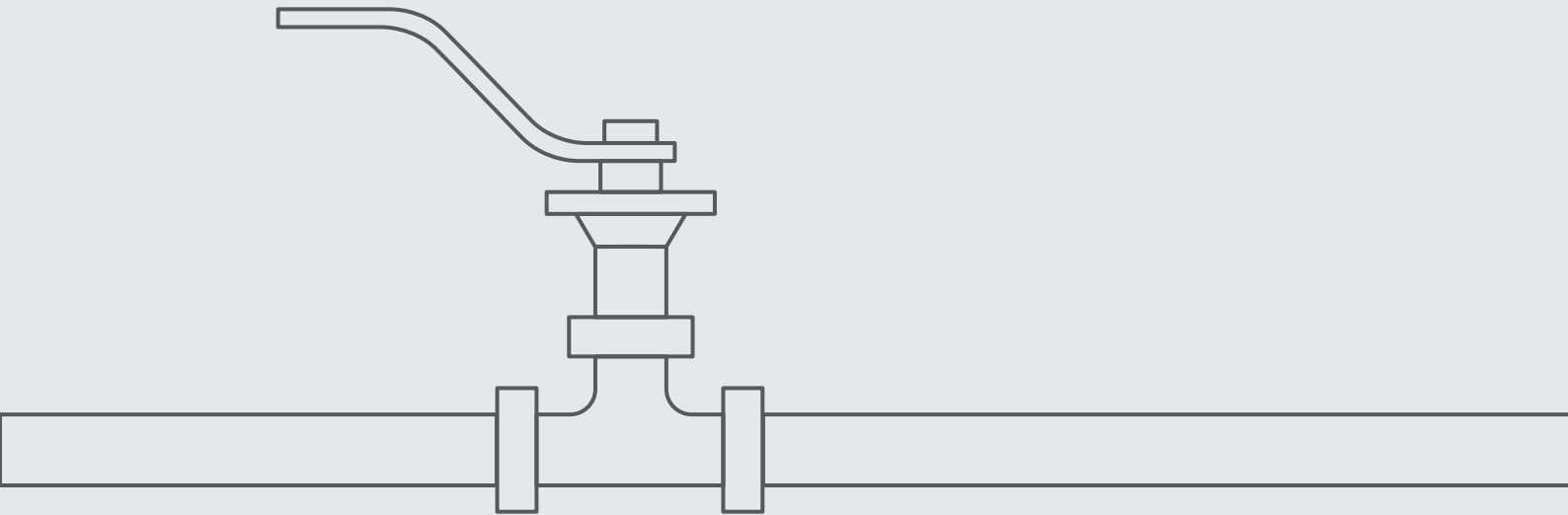



Side Entry - S31, S32

Rotation: 90°

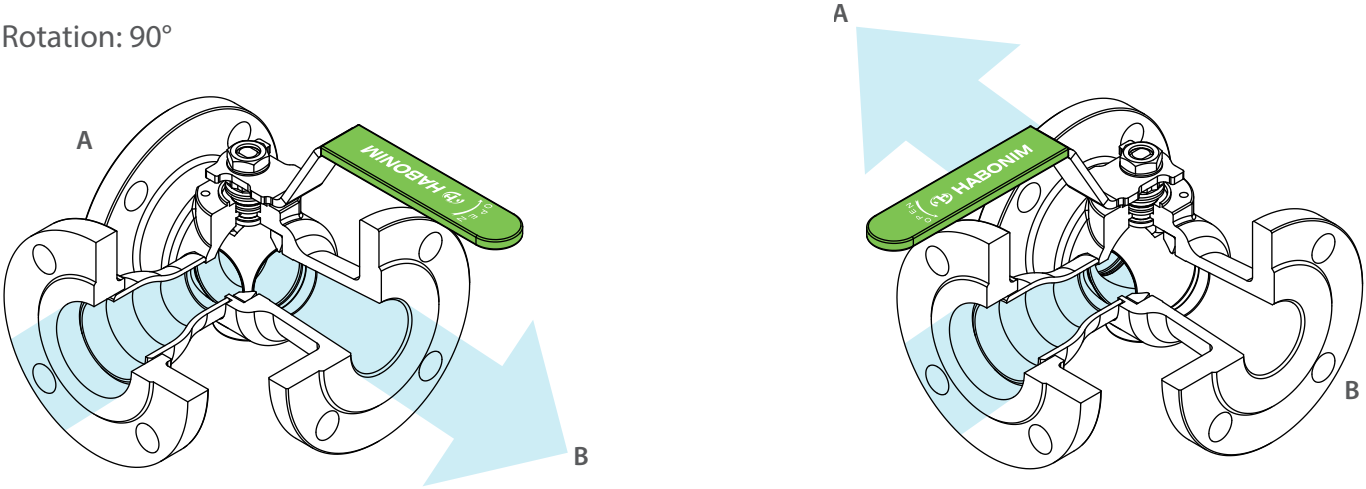

Bottom Entry - D31, D32

Rotation: 90°

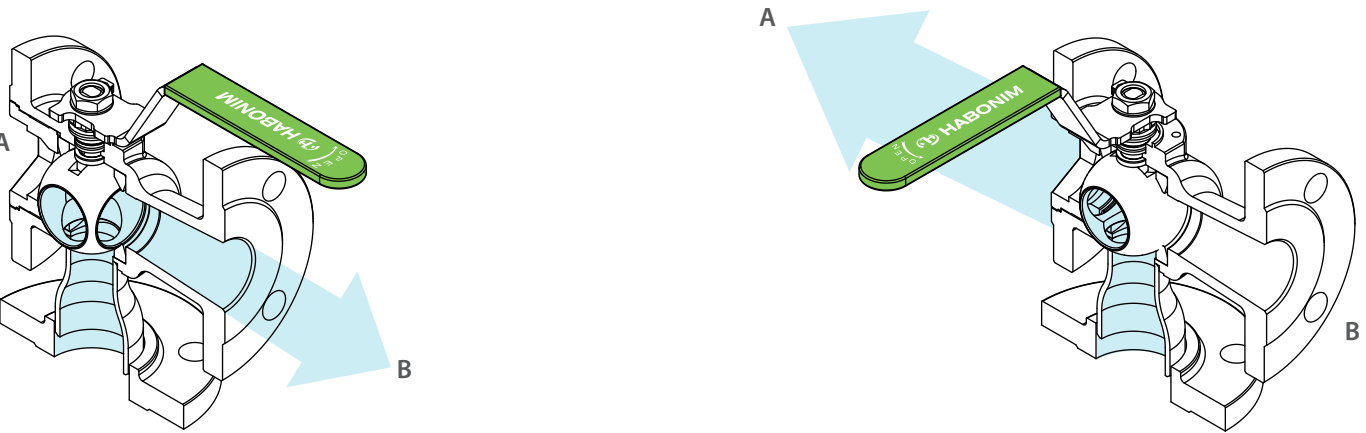

Bottom Entry - D31, D32

Rotation: 180°

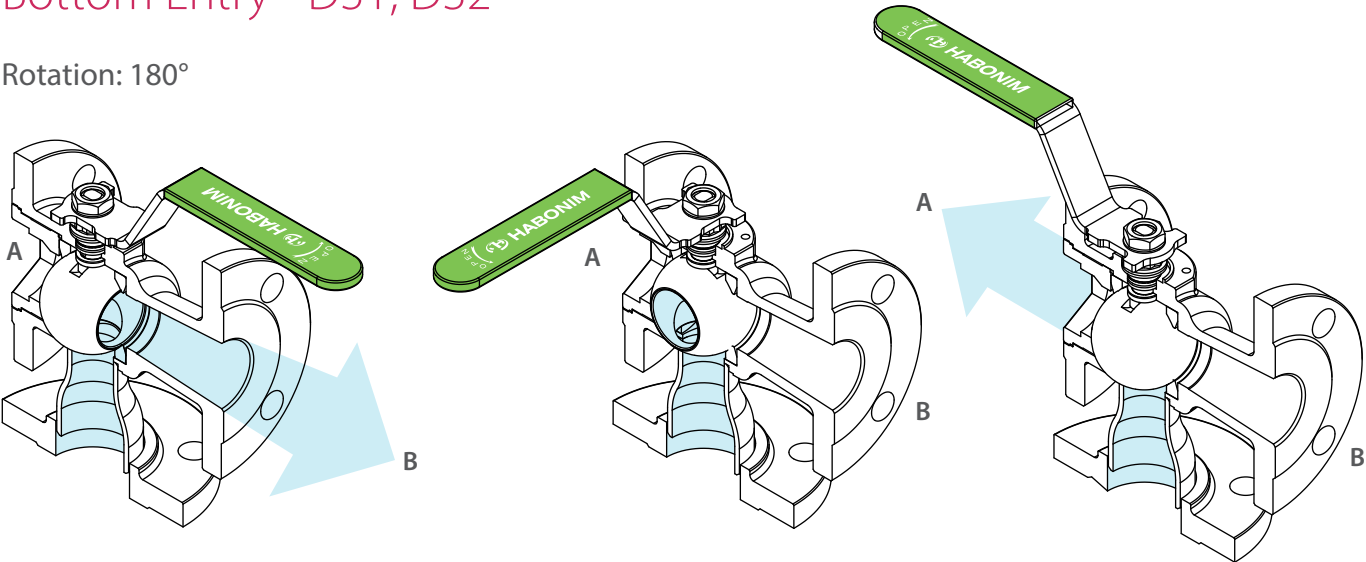

D31

D32

1/2"-2" | DN15-DN50 | CLASS 150/300

Diverter Floating Ball Flanged

Valve Dimensions

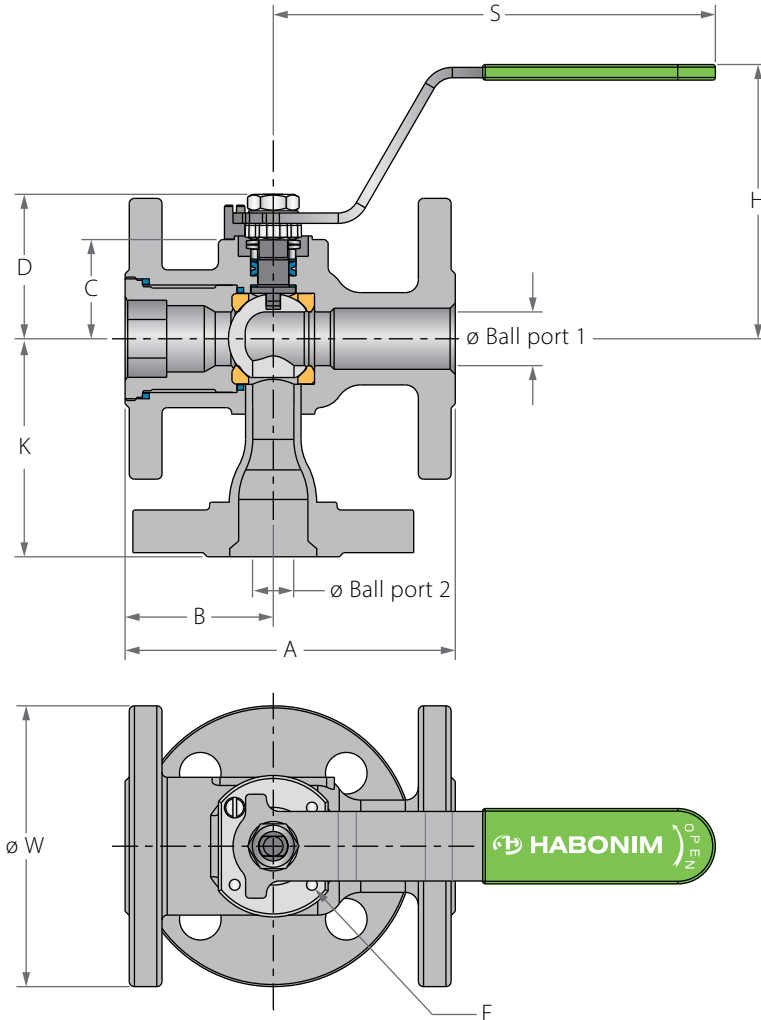

Preparation for actuation

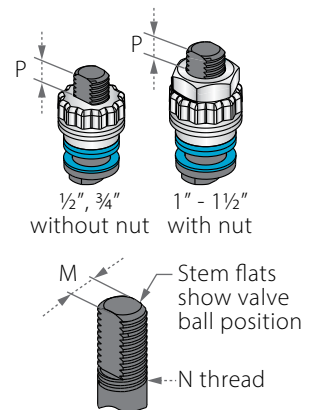

Std. port	Unit	Ball port1	Ball port2	A		B	C	D	H	K		S	W		M	N	P	F	Weight kg/lb		Kv	
				150	300					150	300		150	300					150	300		150
DN15	mm	10.5	9.5	108.0	140.0	46.0	29.0	38.0	92.0	85.5	84.5	151.0	88.90	95.25	5.54	3/8" UNF	6.65	36.0	1.7	2.4	2.8	
1/2"	inch	0.41	0.37	4.25	5.50	1.81	1.14	1.50	3.62	3.4	3.3	5.94	3.50	3.75	0.22		0.26	F03	1.42	3.8	5.3	3.3
DN20	mm	14.3	11.9	117.0	152.0	49.0	31.40	40.30	94.0	77.5		151.0	98.55	163.07	5.54	3/8" UNF	6.65	36.0	2.3	3.3	4	
3/4"	inch	0.56	0.47	4.61	6.0	1.93	1.24	1.59	3.70	3.0		5.94	3.88	6.42	0.22		0.26	F03	1.42	5.1	7.3	5
DN25	mm	20.6	15.9	127.0	165.0	57.0	38.20	55.60	103.50	83.9	109.2	170.0	107.95	123.95	7.54	7/16" UNF	7.40	42.0	3.1	4.6	8	
1"	inch	0.81	0.63	5.0	6.50	2.25	1.50	2.19	4.07	3.3	4.3	6.69	4.25	4.88	0.30		0.29	F04	1.65	7.3	10.2	9
DN40	mm	31.8	26.6	165.0	190.0	62.0	43.60	73.10	119.20	101.6	161.0	220.50	127.0	155.52	8.71	9/16" UNF	8.50	50.0	5.5	8.7	40	
1 1/2"	inch	1.25	1.05	6.50	7.50	2.44	1.72	2.88	4.70	4.0	6.3	8.68	5.0	6.10	0.34		0.33	F05	1.97	12.2	19.3	46
DN50	mm	38.1	35.0	178.0	216.0	68.0	48.30	77.80	123.90	127.8		220.50	152.40	165.10	8.71	9/16" UNF	8.50	50.0	8.1	10.8	42	
2"	inch	1.5	1.38	7.0	8.50	2.67	1.90	3.06	4.88	5.0	5.12	8.68	6.0	6.50	0.34		0.33	F05	1.97	18	24	49



Diverter Floating Ball Flanged

Components & Materials

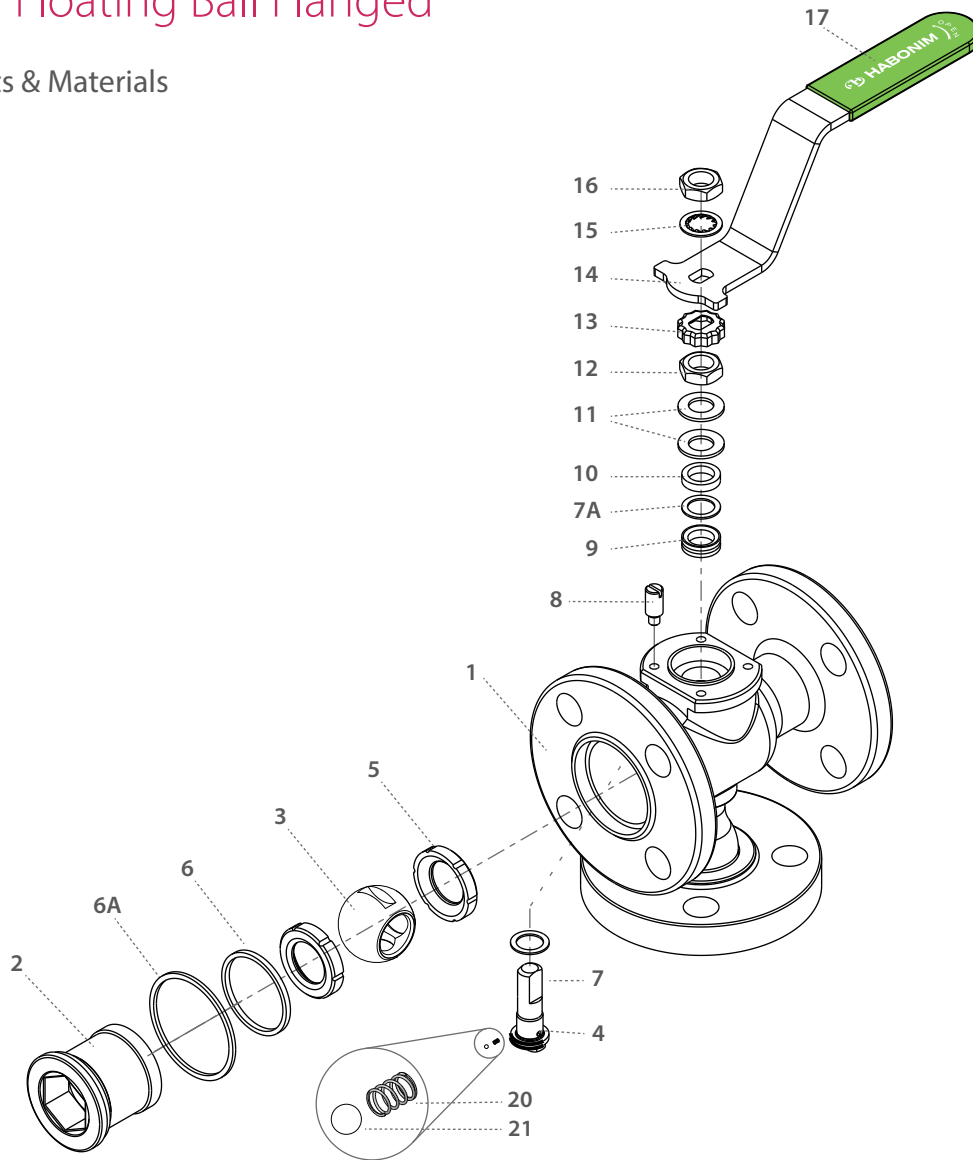

Item	Description	Material specification	Qty.
1	Body	Acc. Ordering Code	1
2	Plug	Acc. Ordering Code	1
3	Ball	Acc. Ordering Code	1
4	Stem	Acc. Ordering Code	1
5*	Seat	Acc. Ordering Code	2
6*	Inner Seal	PTFE	1
6A	Outer Seal	Acc. Ordering Code	1
7*	Stem Thrust Seal	PEEK, CF PEEK, PCTFE	1
7A*	Anti-Abrasion Ring	PEEK, CF PEEK, PCTFE	1
8	Stop Pin	S. Steel	1
9*	Stem Seal	CF PTFE, TFM	1
10	Follower	S. Steel	1

Item	Description	Material specification	Qty.
11	Disc Spring	S. Steel	2
12	Stem Nut	S. Steel	1
13	Locking Clip	S. Steel	1
14	Handle	S. Steel	1
15	Serrated Washer	S. Steel	1
16	Handle Nut	S. Steel	1
17	Sleeve	PVC	1
20	Anti-Static Spring	S. Steel	1
21	Anti-Static Plunger	S. Steel	1
23	Tag (not shown)	S. Steel	1

* Maintenance kit components

D31

D32

3"-8" | DN80-DN200 | CLASS 150/300

Diverter Floating Ball Flanged

Valve Dimensions

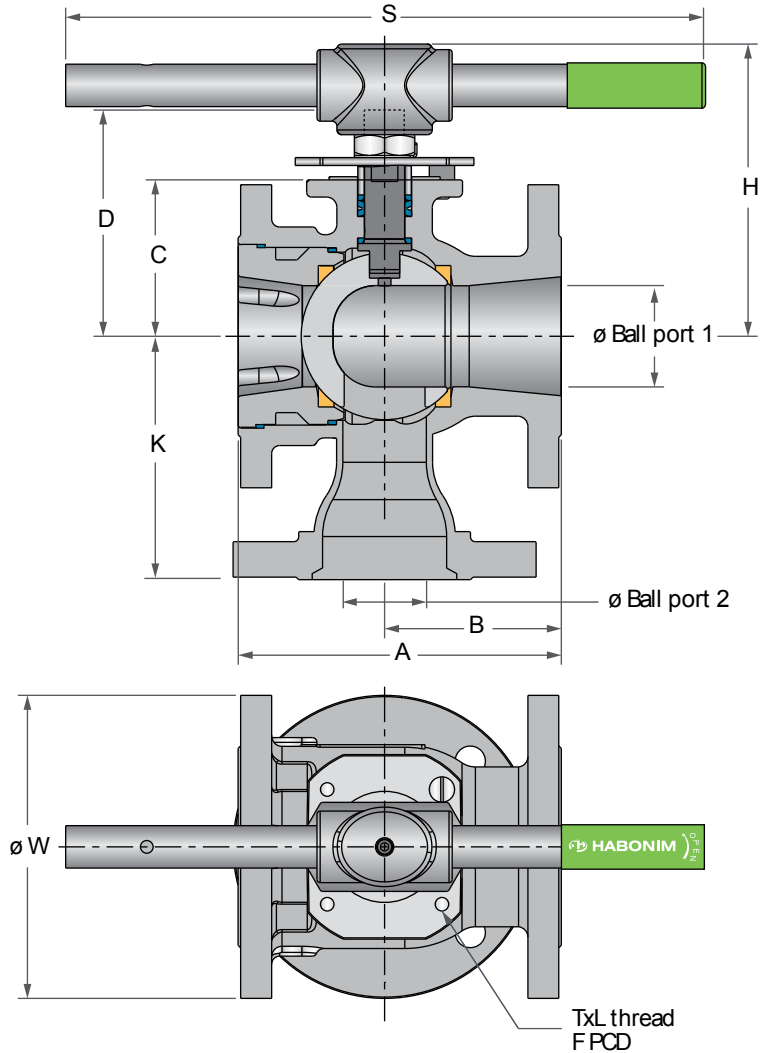

Preparation for actuation

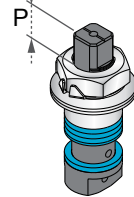

Stem grooves show valve ball position

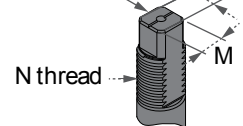

Square

Std. port	Unit	Ball port1	Ball port2	A		B	C	D	H	K		S		W		M	M-DD	N	P	F	TxL	Weight kg/lb		Kv
				150	300					150	300	150	300	150	300							150	300	
DN80	mm	63.50	50.0	203.0	284.0	92.0	98.40	145.0	185.10	153.0	160.0	400.0	190.50	209.55	18.90	15.90	1"-14	16.70	102.0	F10	M10x20	18.00	22.70	129
3"	inch	2.50	1.97	8.0	11.18	3.62	3.88	5.72	7.28	6.02	6.3	15.75	7.50	8.25	0.74	0.63	UNS-2A	0.66	4.02			40.00	50.40	150
DN100	mm	82.60	63.0	229.0	305.0	102.0	114.10	161.0	201.0	185.0		610.0	228.60	254.0	18.90	15.90	1"-14	16.70	102.0	F10	M10x20	28.20	36.30	182
4"	inch	3.25	2.48	9.0	12.0	4.0	4.49	6.34	7.91	7.28		24.01	9.0	10.0	0.74	0.63	UNS-2A	0.66	4.02			62.80	80.60	211
DN150	mm	111.10	78.0	267.0	403.20	108.0	157.40	226.0	285.90	250.0		916.0	279.40	317.50	28.45	23.75	1 1/2"-12	26.20	125.0	F12	M12x20	41.00	69.00	437
6"	inch	4.38	3.07	10.50	15.88	4.25	6.20	8.91	11.25	9.84		36.08	11.0	12.50	1.12	0.94	UNF-2A	1.03	4.92			91.00	153.00	507
DN200	mm	144.40	98.0	292.0	419.0	163.50	185.20	254.0	313.60	300.0		916.0	342.90	381.0	28.45	23.75	1 1/2"-12	26.20	125.0	F12	M12x20	82.00	105.00	698
8"	inch	5.68	3.86	11.50	16.50	5.37	7.30	10.0	12.34	11.81		36.08	13.50	15.0	1.12	0.94	UNF-2A	1.03	4.92			182.00	233.00	810



Diverter Floating Ball Flanged

Components & Materials

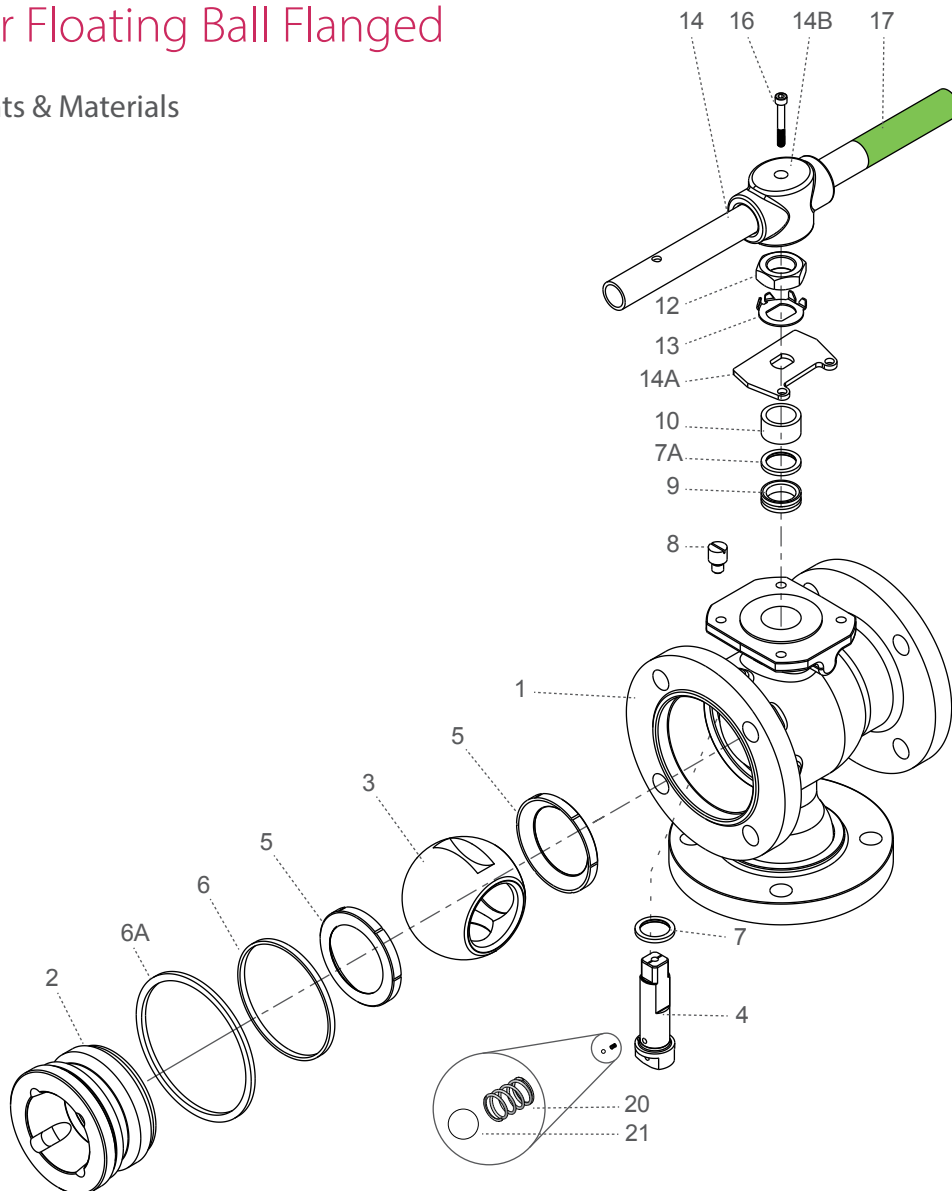

Item	Description	Material specification	Qty.
1	Body	Acc. Ordering Code	1
2	Plug	Acc. Ordering Code	1
3	Ball	Acc. Ordering Code	1
4	Stem	Acc. Ordering Code	1
5*	Seat	Acc. Ordering Code	2
6*	Body Seal	PTFE	1
6A*	Outer Seal	Acc. Ordering Code	
7*	Stem Thrust Seal	PEEK, CF PEEK, PCTFE (KEL-F)	1
7A*	Anti-Abrasion Ring	PEEK, CF PEEK, PCTFE (KEL-F)	1
8	Stop Pin	S. Steel	1
9*	Stem Seal	CF PTFE, TFM	1
10	Follower	S. Steel	1

Item	Description	Material specification	Qty.
11	Disc Spring	S. Steel	2
12	Stem Nut	S. Steel	1
13	Tab Lock Washer	S. Steel	1
14	Handle	S. Steel	1
14A	Stop Plate	S. Steel	1
14B	Wrench Head	S. Steel	1
16	Wrench Bolt	S. Steel	1
17	Sleeve	PVC	1
20	Anti-Static Spring	S. Steel	2
21	Anti-Static Plunger	S. Steel	2
23	Tag (not shown)	S. Steel	1

* Maintenance kit components

Side Entry Floating Ball Flanged

Valve Dimensions

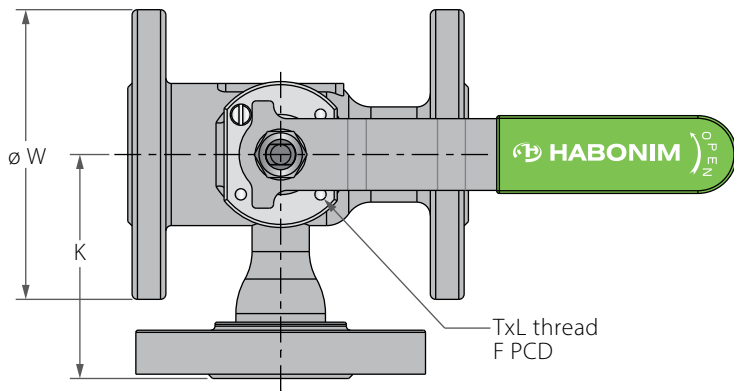
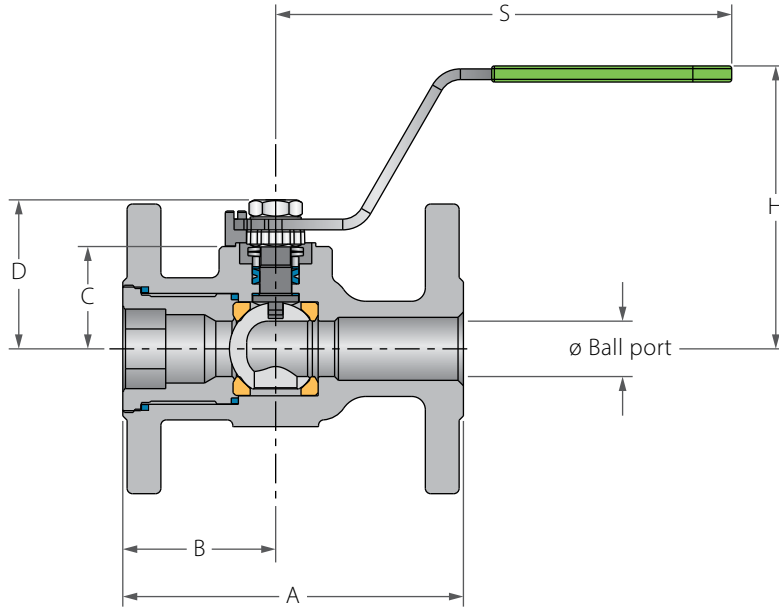

Preparation for actuation

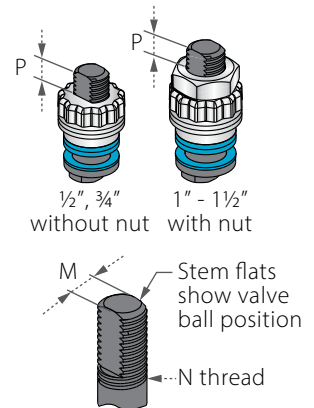

Std. port	Unit	Ball port1	Ball port2	A		B	C	D	H	K		S		W		M	N	P	F	Weight kg/lb		Kv
				150	300					150	300	150	300	150	300					150	300	
DN15	mm	13.50	11.15	108.0	140.0	46.0	29.0	38.0	92.0	84.5	84.5	151.0	88.90	95.25	5.54	3/8"	6.65	F03	36.0	1.7	2.4	2.8
1/2"	inch	0.53	0.44	4.25	5.50	1.81	1.14	1.50	3.62	3.33	3.33	5.94	3.50	3.75	0.22	UNF	0.26		1.42	3.8	5.3	3.3
DN20	mm	17.50	14.30	117.0	152.0	49.0	31.40	40.30	94.0			151.0	98.55	163.07	5.54	3/8"	6.65	F03	36.0	2.3	3.3	4
3/4"	inch	0.69	0.56	4.61	6.0	1.93	1.24	1.59	3.70			5.94	3.88	6.42	0.22	UNF	0.26		1.42	5.1	7.3	5
DN25	mm	23.50	20.60	127.0	165.0	57.0	38.20	55.60	103.50	83.5	109.0	170.0	107.95	123.95	7.54	7/16"	7.40	F04	42.0	3.1	4.6	8
1"	inch	0.93	0.81	5.0	6.50	2.25	1.50	2.19	4.07	3.29	4.29	6.69	4.25	4.88	0.30	UNF	0.29		1.65	7.3	10.2	9
DN40	mm	39.0	31.80	165.0	190.0	62.0	43.60	73.10	119.20	98.5	161	220.50	127.0	155.52	8.71	9/16"	8.50	F05	50.0	5.5	8.7	40
1 1/2"	inch	1.54	1.25	6.50	7.50	2.44	1.72	2.88	4.70	3.88	6.34	8.68	5.0	6.10	0.34	UNF	0.33		1.97	12.2	19.3	46
DN50	mm	48.0	38.20	178.0	216.0	68.0	48.30	77.80	123.90	122.0	129	220.50	152.40	165.10	8.71	9/16"	8.50	F05	50.0	8.1	10.8	42
2"	inch	1.89	1.50	7.0	8.50	2.67	1.90	3.06	4.88	4.8	5.07	8.68	6.0	6.50	0.34	UNF	0.33		1.97	18	24	49



Side Entry Floating Ball Flanged

Components & Materials

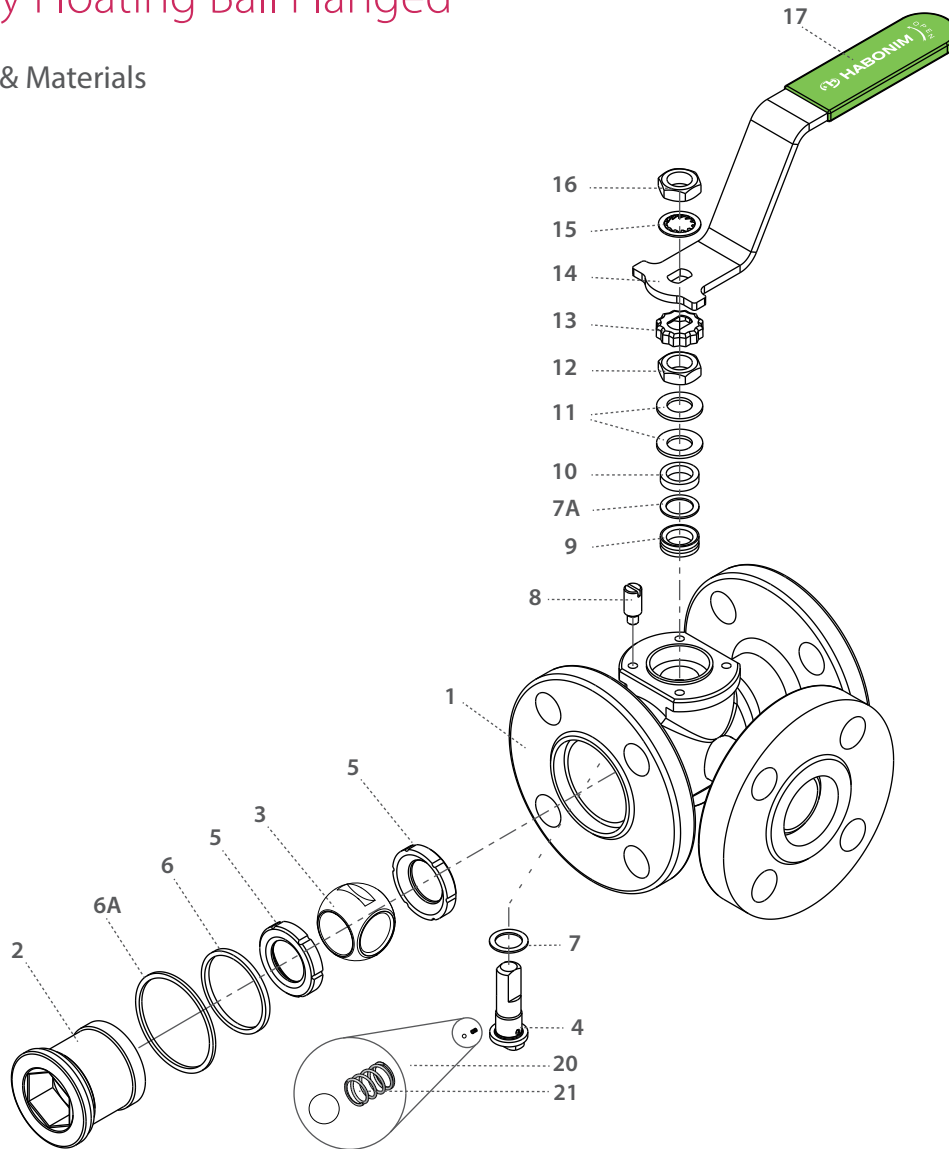

Item	Description	Material specification	Qty.
1	Body	Acc. Ordering Code	1
2	Plug	Acc. Ordering Code	1
3	Ball	Acc. Ordering Code	1
4	Stem	Acc. Ordering Code	1
5*	Seat	Acc. Ordering Code	2
6*	Body Seal	PTFE	1
6A*	Outer Seal	Acc. Ordering Code	1
7*	Stem Thrust Seal	PEEK, CF PEEK, PCTFE	1
7A*	Anti-Abrasion Ring	PEEK, CF PEEK, PCTFE	1
8	Stop Pin	S. Steel	1
9*	Stem Seal	CF PTFE, TFM	1
10	Follower	S. Steel	1

Item	Description	Material specification	Qty.
11	Disc Spring	S. Steel	2
12	Stem Nut	S. Steel	1
13	Locking Clip	S. Steel	1
14	Handle	S. Steel	1
15	Serrated Washer	S. Steel	1
16	Handle Nut	S. Steel	1
17	Sleeve	PVC	1
20	Anti-Static Spring	S. Steel	1
21	Anti-Static Plunger	S. Steel	1
23	Tag (not shown)	S. Steel	1

* Maintenance kit components

Side Entry Floating Ball Flanged

Valve Dimensions

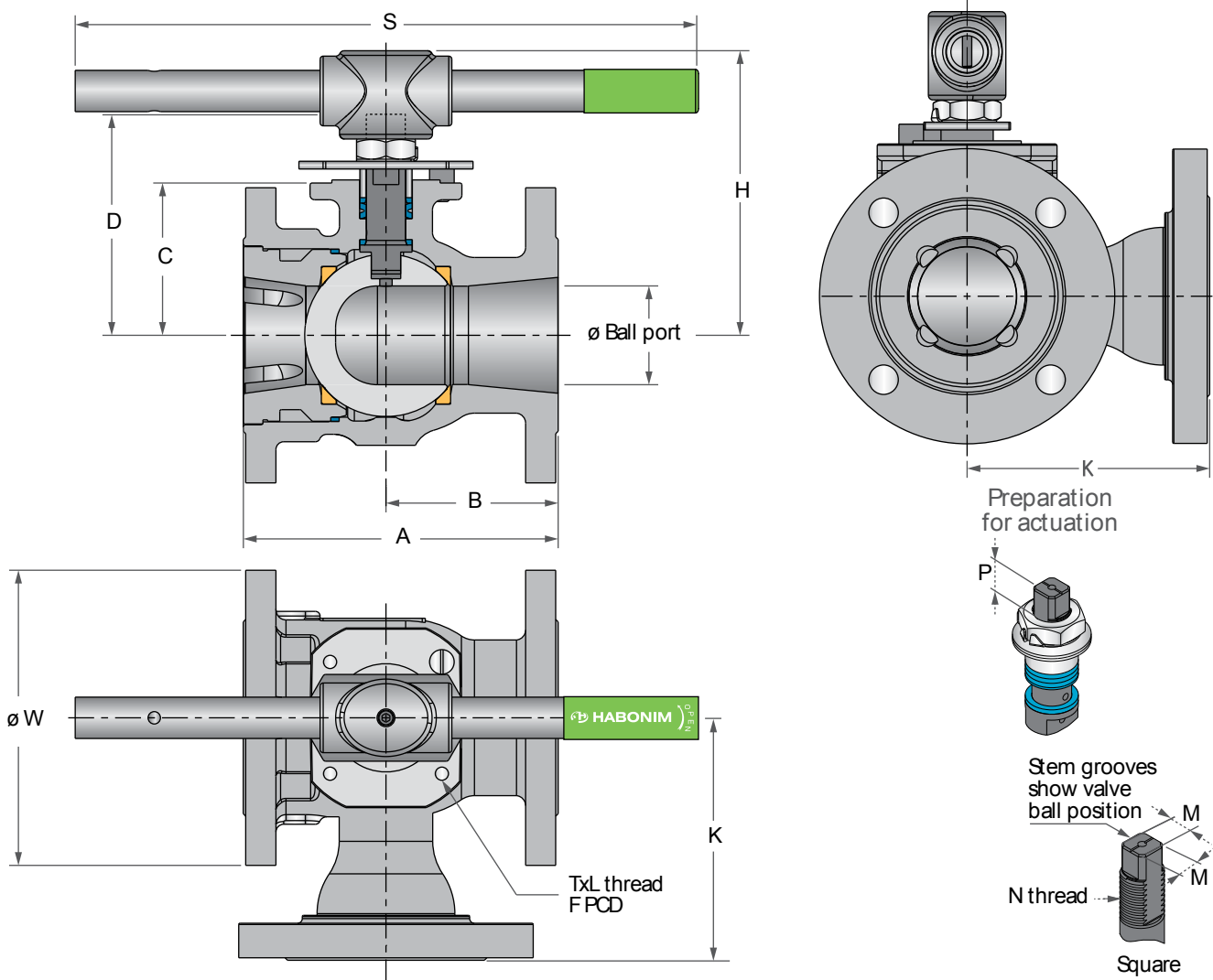

Std. port	Unit	Ball port1	Ball port2	A		B	C	D	H	K		S		W		M	M-DD	N	P	F	TxL	Weight kg/lb		Kv
				150	300					150	300	150	300	150	300							150	300	
DN80	mm	63.50	50.0	203.0	284.0	92.0	98.40	145.0	185.10	156.5	160.2	400.0	190.50	209.55	18.90	15.90	1"-14	16.70	F10	102.0	M10x20	18.00	22.70	129
3"	inch	2.50	1.97	8.0	11.18	3.62	3.88	5.72	7.28	6.16	6.31	15.75	7.50	8.25	0.74	0.63	UNS-2A	0.66	4.02	4.02	M10x20	40.00	50.40	150
DN100	mm	82.60	63.0	229.0	305.0	102.0	114.10	161.0	201.0	185.6	185	610.0	228.60	254.0	18.90	15.90	1"-14	16.70	F10	102.0	M10x20	28.20	36.30	182
4"	inch	3.25	2.48	9.0	12.0	4.0	4.49	6.34	7.91	7.31	7.28	24.01	9.0	10.0	0.74	0.63	UNS-2A	0.66	4.02	4.02	M10x20	62.80	80.60	211
DN150	mm	111.10	78.0	267.0	403.20	108.0	157.40	226.0	285.90	248		916.0	279.40	317.50	28.45	23.75	1½"-12	26.20	F12	125.0	M12x20	41.00	69.00	437
6"	inch	4.38	3.07	10.50	15.88	4.25	6.20	8.91	11.25	9.76		36.08	11.0	12.50	1.12	0.94	UNF-2A	1.03	4.92	4.92	M12x20	91.00	153.00	507
DN200	mm	144.40	98.0	292.0	419.0	163.50	185.20	254.0	313.60		295	916.0	342.90	381.0	28.45	23.75	1½"-12	26.20	F12	125.0	M12x20	82.00	105.00	698
8"	inch	5.68	3.86	11.50	16.50	5.37	7.30	10.0	12.34		11.61	36.08	13.50	15.0	1.12	0.94	UNF-2A	1.03	4.92	4.92	M12x20	182.00	233.00	810



Side Entry Floating Ball Flanged

Components & Materials

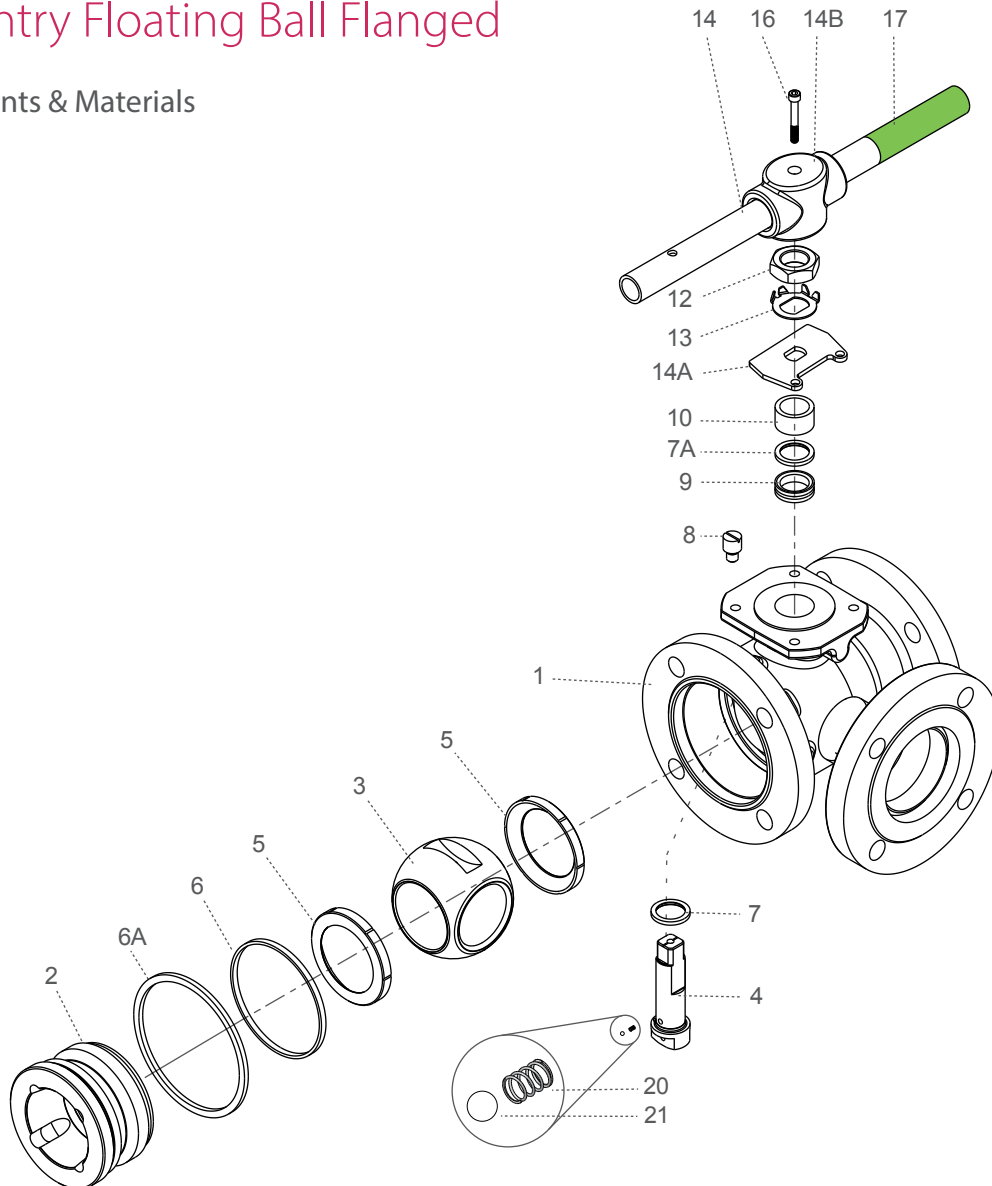

Item	Description	Material specification	Qty.
1	Body	Acc. Ordering Code	1
2	Plug	Acc. Ordering Code	1
3	Ball	Acc. Ordering Code	1
4	Stem	Acc. Ordering Code	1
5*	Seat	Acc. Ordering Code	2
6*	Body Seal	PTFE	1
6A*	Outer Seal	Acc. Ordering Code	
7*	Stem Thrust Seal	PEEK, CF PEEK, PCTFE (KEL-F)	1
7A*	Anti-Abrasion Ring	PEEK, CF PEEK, PCTFE (KEL-F)	1
8	Stop Pin	S. Steel	1
9*	Stem Seal	CF PTFE, TFM	1
10	Follower	S. Steel	1

Item	Description	Material specification	Qty.
11	Disc Spring	S. Steel	2
12	Stem Nut	S. Steel	1
13	Tab Lock Washer	S. Steel	1
14	Handle	S. Steel	1
14A	Stop Plate	S. Steel	1
14B	Wrench Head	S. Steel	1
16	Wrench Bolt	S. Steel	1
17	Sleeve	PVC	1
20	Anti-Static Spring	S. Steel	2
21	Anti-Static Plunger	S. Steel	2
23	Tag (not shown)	S. Steel	1

* Maintenance kit components

D31

S31

D32

S32



Diverter I Side Entry Floating Ball Flanged - Ordering Code System

"Mandatory option" options are marked with **green background** | "Standard offer" options are marked with **light green background**

1	2	3	4	5	6	7	8	9	10	11	12	13	14	15	16	17	18	19	20	21	22	23	24	#	26	.	.	30
6	0				D	3	1	W	-	6	6	6	6	A	T	G	/	1	5	0		9	0					
Size		Features				Series		Design		Body/end material		Ball/Stem material		Seat material	Inner Seal material	Outer Seal material		End connection			Rotation		Special features					

Size (1-2)		
Code	inch	mm
05	½"	15
07	¾"	20
10	1"	25
15	1½"	40
20	2"	50
30	3"	80
40	4"	100
60	6"	150
80	8"	200

Features (3-6)	
D	Diverter bottom entry
S	Diverter side entry
O	Clean assembly for O2 service
H*	H Hydrogen service

* for material selection - see Hydrogen Service chapter

Series (7-8)	
31	ANSI #150 flanged bottom entry
31	ANSI #150 flanged side entry
32	ANSI #300 flanged bottom entry
32	ANSI #300 flanged side entry

Design (9)	
W	Total HermetiX Integrity package

Body/Ends material (11-12)	
6	S. Steel CF8M/CF3M*
4	C. steel A216 WCB/A105
D	Duplex A479
K	Super Duplex A479
S	254SMO A479

* CF3M - for welded ends only.

Ball material (13)	
6	S. Steel CF8M/316
M	High Strength S. Steel
S	254SMO
D	Duplex
K	Super Duplex

Stem material (14)	
6	S. Steel 316
M	High Strength S. Steel
Z	Inconel 718
D	Duplex A479
K	Super Duplex A479
S	254SMO A479

Seat material (15)	
A	TFM
P	CF PTFE
K	CF PEEK
L	Virgin Peek
U	UHMWPE
C	PCTFE
Y	Delrin
W	PVDF
T	PTFE
R	15% Glass filled PTFE

Inner Seal Material (16)	
T	PTFE
A	TFM
G	Expanded graphite
U	UHMWPE
V	Viton
B	NBR

Outer Seal (17)	
G	Expanded graphite
A	TFM

End Connection (19-22)	
Flanged	
150	ASME B16.5 #150 RF
300	ASME B16.5 #300 RF
PN16	EN1092 PN16 RF
PN40	EN1092 PN40 RF

Rotation (23 -25)	
90	90 degrees rotation
180	180 degrees rotation applicable for bottom entry diverter valve L

Special Features (24-30)	
Valve Special Stem Seals	
HC	High Cycle service
AAX	FDA compliant stem seal. TFM thrust bearing and X shape gasket
PPX	CF PTFE thrust and X shape gasket
CAX	PCTFE thrust and TFM X shape gasket
CPX	PCTFE thrust and CF PTFE X shape gasket

R47



Industrial Valves

FLOATING BALL

FLUSH TANK

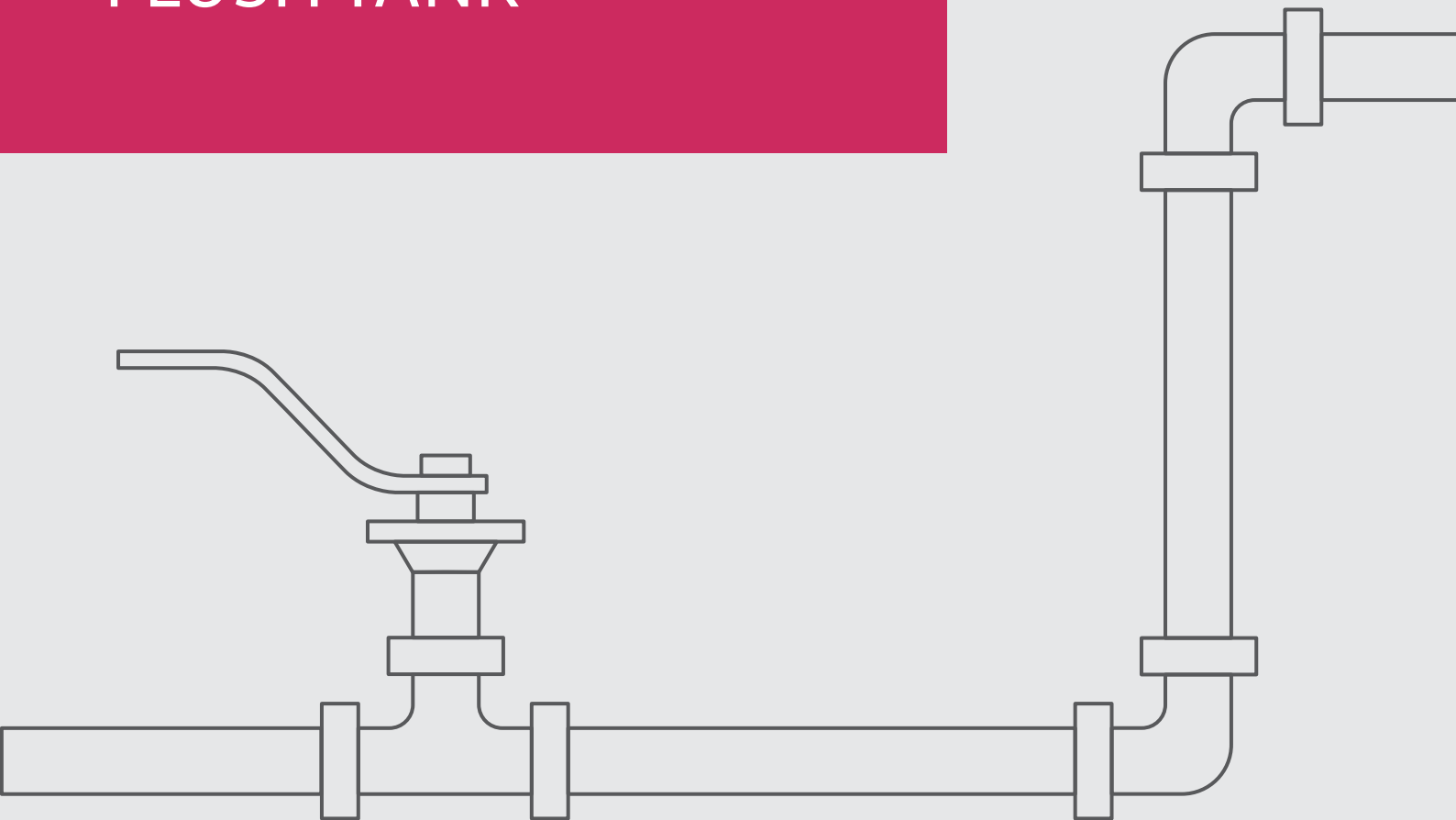

Flush Tank Floating Ball

Introduction

The Habonim Flush Tank series incorporates all the advantages of the 3-piece ball valve 47 series and the TuBore™ 48 series. The innovation of the Flush Tank valve is the geometric design of the pad, which becomes an integral welded part of the customer's tank surface, allowing a smooth flow and preventing media stagnation. The result is a perfect adaptor between reactor and valve body.

The pad is designed for easy installation. It minimizes the diameter of the prepared tank bore, reduces installation time and welding operations and, most importantly, minimizes the stress concentration and tank deformation due to weld over-heating. The Habonim standard flush tank pad fits most tank configurations such as dished, flat, ellipsoidal, jacketed, conical or spherical. For special applications, such as replacing a conventional flush tank valve with a direct flow, higher Cv, quarter-turn flush tank ball valve, Habonim manufactures adaptive plates.

Habonim can also ship the pad independently from the valve, in order to accommodate customer requirements to simplify the vessel construction process.

Design Features

Pad design

- Mirror polished
- Various geometries: dished, flat, ellipsoidal, Jacketed, conical or spherical
- Flush Pipe (FP) – Adaptive pad with the same geometry of the pipe line, designed to provide minimum 'dead volume' in pipe lines, preventing media from stagnating and fully insuring drainage of pipe cavities.

Body

- Minimum dead leg between ball sphere and tank internal surface
- Three-piece design with swing-out body, for easy maintenance
- Top mounting platform compliant with ISO 5211 for easy mounting of actuator and other accessories
- CIP/SIP purge ports ensure complete flush of the valve cavity (optional)
- Steam jacket (optional)
- Streamlined flow ensures full drainage



R47



Flush Tank Floating Ball

Mirror polished pad

Minimum dead leg

Variety of seat materials

HermetiX™ stem seal

Mirror polished solid ball

No restrictions ensure full drainage



Flush Tank Floating Ball

Valve Dimensions

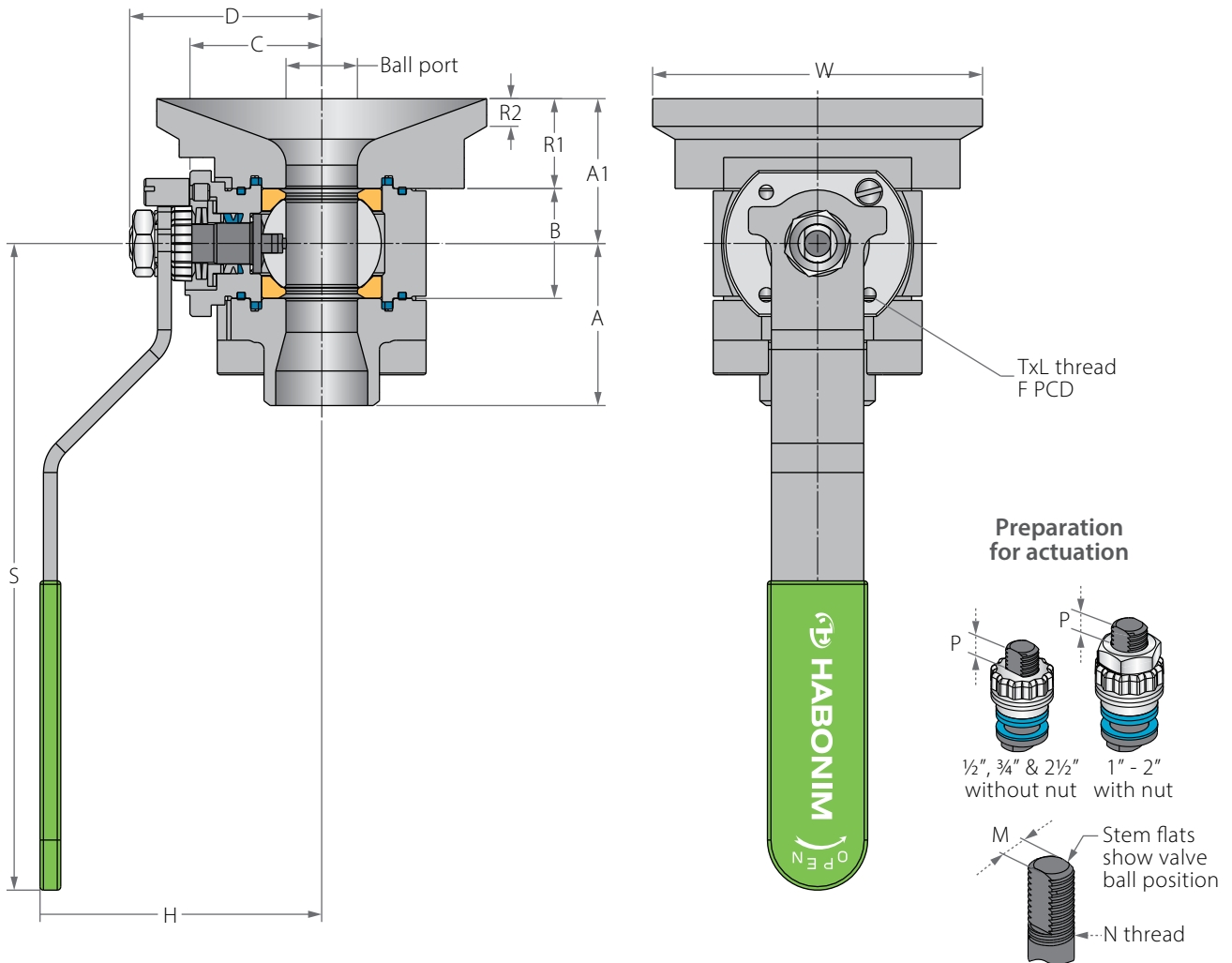

Std. port	Full port	Unit	Ball port	R1	R2	A	A1	B	C	D	H	S	W	M	N	P	F	TxL	Weight kg/lb	Kv Cv	
DN15	DN10	mm	11.15	21.0	6.0	33.0	31.30	20.60	29.0	38.70	61.50	150.0	60.0	16.0	3/8"	6.65	F03	36.0	M5X10	0.8	6.9
1/2"	3/8"	inch	0.44	0.83	0.24	1.30	1.24	0.81	1.14	1.52	2.42	5.91	2.36	0.63	UNF	0.26				1.42	1.9
DN20	DN15	mm	14.30	20.60	6.0	35.30	32.85	24.50	31.40	40.30	63.90	150.0	80.0	5.54	3/8"	6.65	F03	36.0	M5X10	1.2	10
3/4"	1/2"	inch	0.56	0.81	0.24	1.39	1.29	0.97	1.24	1.59	2.52	5.91	3.15	0.22	UNF	0.26				1.42	2.6
DN25	DN20	mm	20.60	21.50	8.0	46.90	37.35	31.70	38.20	55.60	79.40	187.0	95.50	7.54	7/16"	7.40	F04	42.0	M5X10	2.1	28
1"	3/4"	inch	0.81	0.85	0.31	1.85	1.47	1.25	1.50	2.19	3.13	7.36	3.76	0.30	UNF	0.29				1.65	4.6
DN32	DN25	mm	25.50	24.0	8.0	54.0	45.0	41.25	42.64	60.24	87.0	187.0	108.0	7.54	7/16"	7.40	F04	42.0	M5X10	3.2	49
1 1/4"	1"	inch	1.0	0.94	0.31	2.13	1.77	1.62	1.67	2.37	3.42	7.36	4.25	0.30	UNF	0.29				1.65	7.0
DN40	DN32	mm	31.80	27.0	8.0	57.80	51.20	48.40	43.60	73.0	97.0	237.0	113.0	8.71	9/16"	8.50	F05	50.0	M6X12	4.5	69
1 1/2"	1"	inch	1.25	1.06	0.31	2.28	2.01	1.91	1.72	2.87	3.82	9.33	4.45	0.34	UNF	0.33				1.97	9.9
DN50	DN40	mm	38.10	29.0	10.0	64.0	57.15	56.30	48.30	77.80	101.80	237.0	138.0	8.71	9/16"	8.50	F05	50.0	M6X12	5.8	102
2"	1 1/2"	inch	1.50	1.14	0.39	2.52	2.25	2.22	1.90	3.06	4.01	9.33	5.43	0.34	UNF	0.33				1.97	12.8
DN65	DN50	mm	50.80	30.0	10.0	79.0	66.30	72.60	70.0	88.10	115.10	237.0	164.0	8.71	9/16"	13.50	F07	70.0	M8X12	11.1	208
2 1/2"	2"	inch	2.0	1.18	0.39	3.11	2.61	2.86	2.76	3.47	4.53	9.33	6.46	0.34	UNF	0.53				2.76	24.4



Flush Tank Floating Ball

Components & Materials

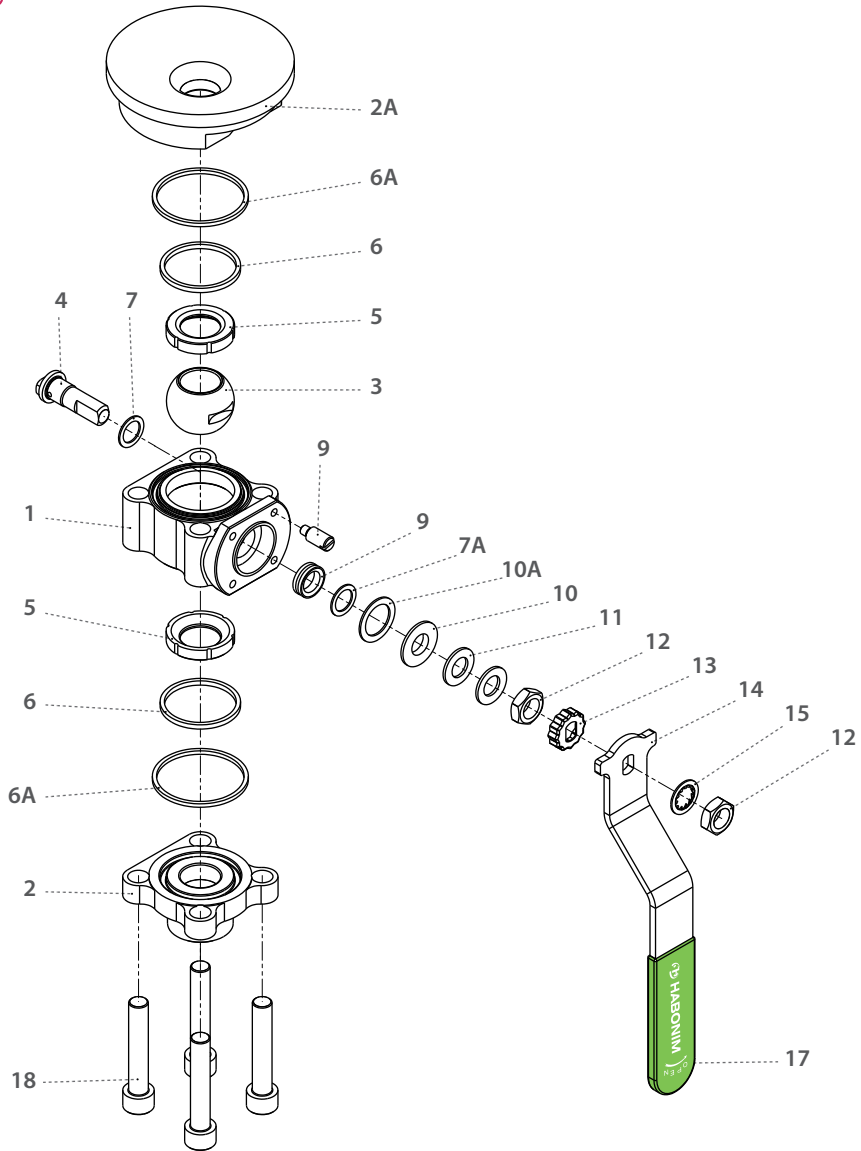

Item	Description	Material specification	Qty.
1	Body	Acc. Ordering Code	1
2	End	Acc. Ordering Code	1
2A	FT End	Acc. Ordering Code	1
3	Ball	Acc. Ordering Code	1
4	Stem	Acc. Ordering Code	1
5*	Seat	Acc. Ordering Code	2
6*	Inner Seal	Acc. Ordering Code	2
6A*	Outer Seal	Acc. Ordering Code	2
7*	Stem Thrust Seal	V. PEEK, CF PEEK, PCTFE	1
7A*	Anti-Abrasion Ring	V. PEEK, CF PEEK, PCTFE	1
8	Stop Pin	S. steel	1

Item	Description	Material specification	Qty.
9*	Stem Seal	CF PTFE, TFM	1
10	Follower	S. Steel	1
10A*	Slide Bearing	S. Steel	1
11	Disc Spring	S. Steel	2
12	Stem Nut	S. Steel	1
13	Locking Clip	S. Steel	1
14	Handle	S. Steel	1
15	Serrated Washer	S. Steel	1
16	Handle Nut	S. Steel	1
17	Sleeve	PVC	1
18	Body Bolt	S. Steel	4

* Maintenance kit components

Flush Tank Floating Ball

Valve Dimensions

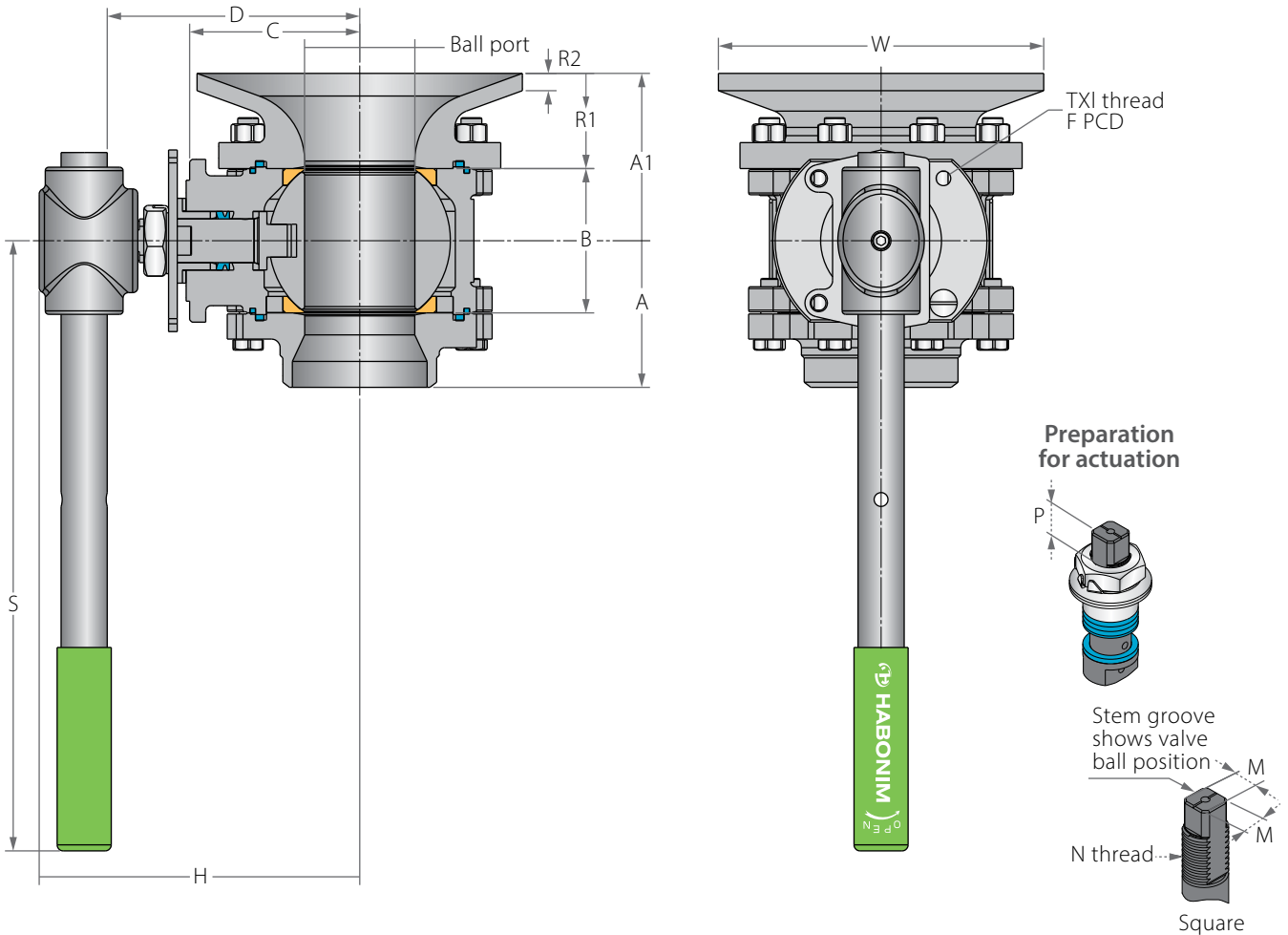

Std. port	Full port	Unit	Ball port	R1	R2	A	A1	B	C	D	H	S	W	M-DD	M	N	P	F	TxL	Weight kg/lb	Kv Cv	
DN80	DN65	mm	63.50	34.0	10.0	84.50	75.65	83.30	98.30	144.90	185.0	400.0	188.0	15.90	18.90	1"-14	16.70	F10	102.0	M10x20	15.5	300
3"	2½"	inch	2.50	1.34	0.39	3.33	2.98	3.28	3.87	5.71	7.29	15.75	7.40	0.63	0.74	UNS-2A	0.66		4.02		34.1	348
DN100	DN80	mm	82.60	38.0	10.0	107.0	92.40	108.80	114.10	160.70	200.0	600.0	226.0	15.90	18.90	1"-14	16.70	F10	102.0	M10x20	26.0	615
4"	3"	inch	3.25	1.50	0.39	4.21	3.64	4.28	4.49	6.33	7.89	23.62	6.97	0.63	0.74	UNS-2A	0.66		4.02		57.2	713
	DN100	mm	100.0	45.0	12.0	119.50	106.50	123.0	124.0	170.50	211.0	600.0	252.0	15.90	18.90	1"-14	16.70	F10	102.0	M10x20	34.0	744
	4" FB	inch	3.94	1.77	0.47	4.70	4.19	4.84	4.88	6.71	8.30	23.62	8.54	0.63	0.74	UNS-2A	0.66		4.02		74.8	863



Flush Tank Floating Ball

Components & Materials

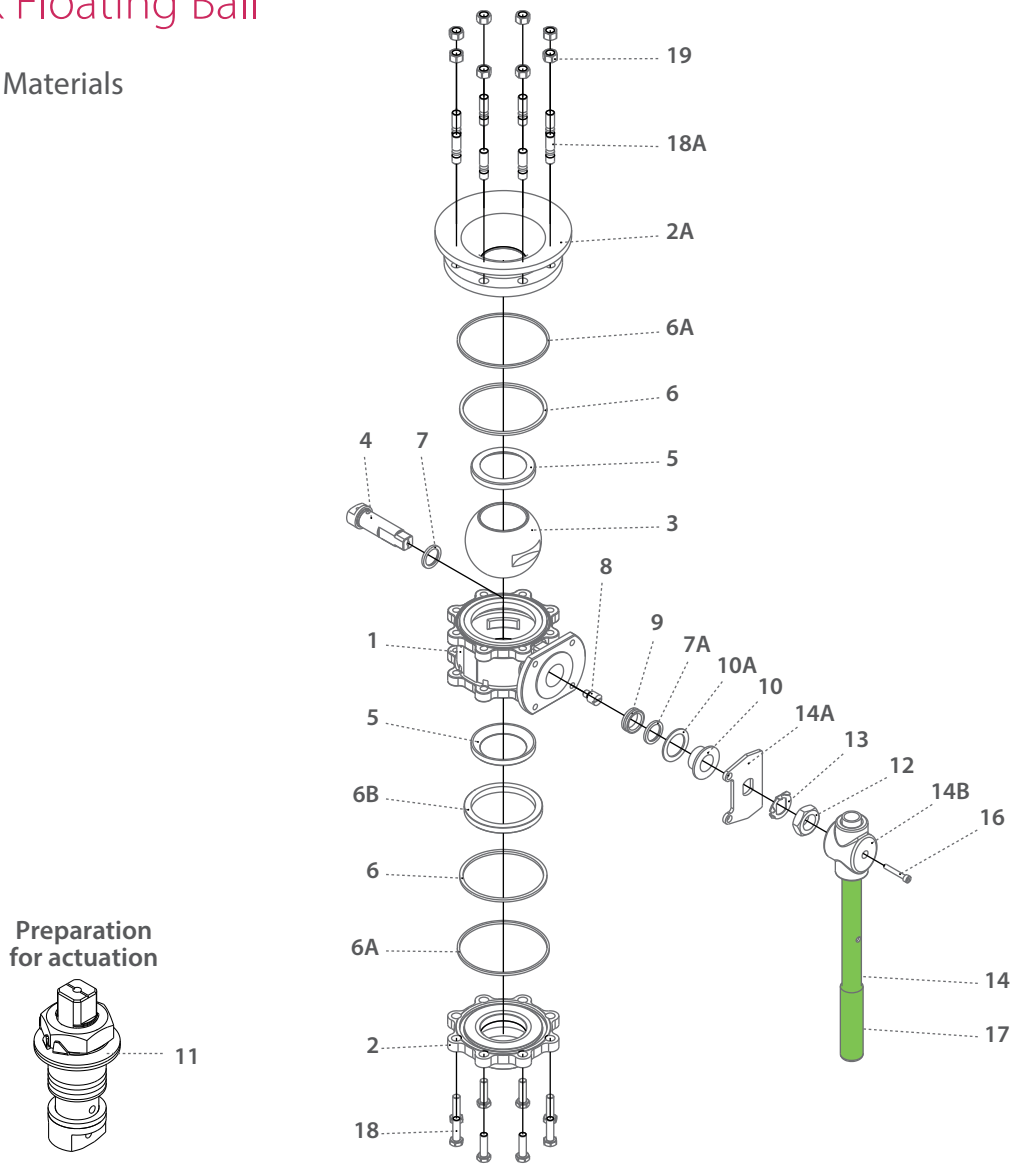

Item	Description	Material specification	Qty.
1	Body	Acc. Ordering Code	1
2	End	Acc. Ordering Code	1
2A	Ft End	Acc. Ordering Code	1
3	Ball	Acc. Ordering Code	1
4	Stem	Acc. Ordering Code	1
5*	Seat	Acc. Ordering Code	2
6*	Inner Seal	Acc. Ordering Code	2
6A*	Outer Seal	Acc. Ordering Code	2
6B	Support Ring	S. Steel	1
7*	Stem Thrust Seal	V. PEEK, CF PEEK, PCTFE	1
7A*	Anti-Abrasion Ring	V. PEEK, CF PEEK, PCTFE	1
8	Stop Pin	S. Steel	1
9*	Stem Seal	CF PTFE, TFM	1

Item	Description	Material specification	Qty.
10	Follower	S. Steel	1
10A*	Slide Bearing	S. Steel	1
11	Disc Spring	S. Steel	2
12	Stem Nut	S. Steel	1
13	Locking Clip	S. Steel	1
14	Handle	S. Steel	1
14A	Stop Plate	S. Steel	1
14B	Wrench Head	S. Steel	1
16	Wrench Bolt	S. Steel	1
17	Sleeve	PVC	1
18	Bolts	S. Steel	8
18A	Body Bolts	S. Steel	8
19	Body Nut	S. Steel	8

* Maintenance kit components



Flush Tank Floating Ball - Ordering Code System

"Mandatory option" options are marked with **green background** | "Standard offer" options are marked with **light green background**

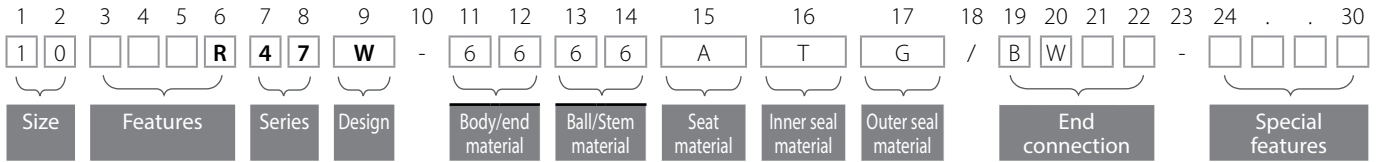

Size (1-2)		
Code	inch	mm
05	½"	15
07	¾"	20
10	1"	25
12	1¼"	32
15	1½"	40
20	2"	50
25	2½"	65
30	3"	80
40	4"	100

Features (3-6)	
R	Flush tank
F	Fire safe
B	Full port
O	Clean assembly for O2 service
M	Ammonia service
K	Chlorine service
V	Vacuum service
Q	Cavity filler seats

Series (7-8)	
47	Floating ball 3 piece

Design (9)	
W	Total HermetiX

Body material (11)	
6	S. Steel CF8M
4	C. steel
W	Hastelloy-C22
S	254SMO
D	Duplex
9	Low Temp C. steel
1	Bronze
K	Super Duplex
7	Monel
A	Alloy-20
C	Hastelloy-C276

Ends material (12)	
6	S. Steel CF8M/CF3M*
4	C. steel
W	Hastelloy-C22
S	254SMO
D	Duplex
9	Low Temp C. steel
1	Bronze
K	Super Duplex
7	Monel
A	Alloy-20
C	Hastelloy-C276

Ball material (13)	
6	S. SteelCF8M/316
W	Hastelloy-C22
S	254SMO
D	Duplex
1	Bronze
K	Super Duplex
7	Monel
A	Alloy-20
C	Hastelloy-C276

Stem material (14)	
6	S. Steel316
M	High Strength S. Steel
Z(1)*	Inconel 718
W	Alloy-C22
S	254SMO A479
A	Alloy-20
D	Duplex A479
K	Super Duplex A479
7	Monel
C	Hastelloy-C276

Seat material (15)	
A	TFM
P	CF PTFE
K	CF PEEK
L	Virgin Peek
U	UHMWPE
C	PCTFE
Y	Delrin
W	PVDF
T	PTFE
R	15% Glass filled PTFE

Inner Seal Material (16)	
T	PTFE
A	TFM
G	Expanded graphite
U	UHMWPE
V	Viton
B	NBR

Outer Seal Material (17)	
G	Expanded graphite
A	TFM
U	UHMWPE

End Connection (19-22)	
Welded ends	
BW10	Buttweld schd. 10
BW	Buttweld schd. 40
SW	Socket weld
XBW10	Extended buttweld schd. 10
XBW	Extended buttweld schd. 40
XSW	Extended socket weld
BW5	Buttweld schd. 5
BW80	Buttweld schd. 80
BWO*	Buttweld tube OD
BWD	Buttweld DIN 11850
BW1.6	buttweld ISO 1127 1.6mm
BW12.0	buttweld ISO 1127 2.0mm
BW12.3	buttweld ISO 1127 2.3mm
SWO*	Socket weld tube OD
ETO*	Extended tube OD
ET1.6	Extended buttweld ISO 1127 1.6mm
ET12.0	Extended buttweld ISO 1127 2.0mm
ET12.3	Extended buttweld ISO 1127 2.3mm
ETD	Extended buttweld DIN 11850

Threaded	
NPT	ASME B1.20.1 - National Pipe Taper thread
BSPT	EN 10226 - Pipe Taper thread
BSPP	ISO228-1, DIN3852 - Pipe Parallel thread
DIN3852	DIN3852 - Pipe Parallel thread
AS5202	SAE internal straight thread
MNPT	Male NPT
MBSPT	Male BSPT

Flanged	
150	ASME B16.5 #150 RF
300	ASME B16.5 #300 RF
600	ASME B16.5 #600 RF
900	ASME B16.5 #900 RF
PN16	EN1092 PN16 RF
PN40	EN1092 PN40 RF
PN63	EN1092 PN63 RF
PN100	EN1092 PN100 RF
PN160	EN1092 PN160 RF

Clamp	
LL*	Compression fitting (Imperial) - No Nuts & Ferrules
LM*	Compression fitting (metric) - No Nuts & Ferrules
LL-NF*	Compression fitting (Imperial) - with Nuts & Ferrules
LM-NF*	Compression fitting (metric) - with Nuts & Ferrules
GR**	Grayloc® compatible hub (Grayloc® is a registered trademark of Grayloc Products, L.L.C.)
TC*	Tri-Clamp

Special Features (24-30)	
P250	Ball with Upstream Relief Hole
SRS	Self Relief Seat - TFM seat only
B	Body made from barstock
EP	Electropolished
J2N05	Jacketed valve - number of ports (2), type (NPT) and size (½")
Valve Special Stem Seals	
AAX	FDA compliant stem seal. TFM thrust bearing and X shape gasket
PPX	CF PTFE thrust and X shape gasket
CAX	PCTFE thrust and TFM X shape gasket
CPX	PCTFE thrust and CF PTFE X shape gasket
HC	High Cycle service

* CF3M - for welded ends only.

* Std. port only

** Not available for 1¼" (DN32) Valves



YP0005126 CAT-PRD-INDS-M ver04_L190326

About Habonim

Ball Valves & Actuators for the most demanding, challenging and hazardous applications are our passion and profession for the last 70 years.

We believe in designing, manufacturing and supplying control and shutoff components and solutions that improves the overall safety, integrity and sustainability of the systems they are installed in.

Designed, manufactured and tested according to the highest standards, our products allow us to partner within systems that flow and control varied gases and liquids in diverse markets especially where extreme temperatures and pressures are involved, hazardous materials are used and system performances are critical.

We are leading in cryogenic ball valve-based control solutions, emergency shutoff and specially designed solutions.

Believing that supplying and developing the most effective, safe and reliable products for the global leaders in the LNG and Gas distribution market continually challenges us to improve our capabilities and products.

Best coping with our prestigious customers' most challenging requirements technically, operationally and commercially is our promise fulfilled for decades.

Performing in Demanding Applications



www.habonim.com

Habonim USA +1 866 261 8400 | Habonim Canada +1 866 261 8400 | Habonim EU +31 79 204 0781 | Habonim Singapore +65 8127 0221
Habonim China +86 186 168 08766 | Habonim Israel +972 (0) 4 691 4911 | Habonim Australia +65 8127 0221 | Habonim Mexico +52 55 1384 3048